

# The line shape of sodium $n^2S_{1/2} - 3^2P_{1/2;3/2}$ transitions in Na-Cd high pressure discharge

---

Mioković, Željka; Veža, Damir

Source / Izvornik: **Fizika A**, 2001, 10, 129 - 140

Journal article, Published version

Rad u časopisu, Objavljena verzija rada (izdavačev PDF)

Permanent link / Trajna poveznica: <https://um.nsk.hr/um:nbn:hr:217:950269>

Rights / Prava: [In copyright](#) / [Zaštićeno autorskim pravom](#).

Download date / Datum preuzimanja: **2024-07-21**



Repository / Repozitorij:

[Repository of the Faculty of Science - University of Zagreb](#)



THE LINE SHAPE OF SODIUM  $n^2S_{1/2}-3^2P_{1/2;3/2}$  TRANSITIONS IN Na-Cd  
HIGH PRESSURE DISCHARGEŽELJKA MIOKOVIĆ<sup>a</sup> and DAMIR VEŽA<sup>b</sup><sup>a</sup>*Electrotechnical faculty, K. Trpimira 2b, 31000 Osijek, Croatia*<sup>b</sup>*Department of Physics, P.O.B. 331, Bijenička 32, HR-10002 Zagreb, Croatia  
Tel.: +385-1-4605555 E-mail address: veza@phy.hr***Dedicated to Professor Kseno Ilakovac on the occasion of his 70<sup>th</sup> birthday**

Received 20 July 2001; revised manuscript received 11 December 2001

Accepted 26 November 2001 Online 30 December 2001

We measured sodium atomic lines belonging to the  $n^2S_{1/2}-3^2P_{1/2;3/2}$  ( $n = 5, 6, 7$ ) series, originating from a high-pressure sodium-cadmium plasma. The observed line shapes are compared with the calculations of the line shapes made within the Bartels' method. The electron density is estimated by Vidal approach (a refined Inglis-Teller method), and the density of sodium and cadmium has been determined using the relationships between the interaction constants of the sodium-sodium (sodium-cadmium) quasimolecule and the shift of the self-absorbed peaks of the sodium resonance line. We assume that the main line-broadening mechanisms of  $n^2S_{1/2}-3^2P_{1/2;3/2}$  spectral lines are Stark broadening (by electrons), self-broadening (by neutral sodium atoms) and van der Waals broadening (by cadmium atoms). The electron temperatures are determined by Bartels' method, fitting the calculated to the experimentally measured  $n^2S_{1/2}-3^2P_{1/2;3/2}$  line profiles. All three measured lines possess a red asymmetry that can not be attributed to the electron broadening, self-broadening or foreign gas broadening. We suggest that this red asymmetry could be caused by interaction of the radiating sodium atom with sodium and cadmium ions.

PACS numbers: 32.70.-n, 52.25.Rv

UDC 537.525

Keywords: high-pressure Na-Cd plasma, atomic lines,  $n^2S_{1/2}-3^2P_{1/2;3/2}$  ( $n = 5, 6, 7$ ) series, line shapes, Stark broadening by electrons, self-broadening, van der Waals broadening, red asymmetry

## 1. Introduction

The high-pressure sodium-mercury vapour discharge lamp was invented for lighting purposes almost 40 years ago [1], and further developed and refined during last few decades [2]. From the plasma spectroscopist point of view, it is a wall-stabilized electric discharge burning at normal or elevated pressures, enabling studies of fundamental atomic processes in mixed-vapour plasmas. The lamp burner is made of high-density polycrystalline translucent alumina ceramics (PCA tube) with electrodes cemented to the tube ends. The PCA is highly resistant to corrosive sodium vapour at elevated temperatures up to 1800 K, and it has also a high transmission coefficient (better than 90%) for visible radiation. However, a disadvantage is that PCA is not transparent but translucent, so that standard conventional plasma diagnostic techniques for determination of various plasma parameters are not easily applicable to this radiation source.

The standard high-pressure sodium lamp, based on the sodium-mercury-xenon filling (xenon is used as the starting gas) has been widely investigated during last few decades [2]. The sodium-cadmium-xenon discharge, a similar high-pressure discharge, has been already investigated in order to confirm similarities in the radiation spectra of NaHg, KHg [3] and NaCd [4] molecules (satellite continua), but has been rarely investigated by conventional plasma diagnostic techniques for the determination of its plasma parameters [5]. In this paper we report preliminary measurements of line-shape of the  $nS-3P$  ( $n = 5, 6, 7$ ) sodium atomic lines, radiated by the high-pressure sodium-cadmium plasma generated in a translucent sapphire burner. The line-shapes are measured and analyzed using the spectroscopic procedure developed by H. Bartels [6]. We undertook this study in order to find out mechanisms leading to the formation of  $nS-3P$  ( $n = 5, 6, 7$ ) line-profiles and to test or determine the corresponding broadening mechanisms and the interaction constants. Surprisingly, the shift and the broadening of higher members of  $nD-3P$  ( $n > 4$ ) series and especially  $nS-3P$  ( $n = 5, 6, 7$ ) series are much less investigated, compared to the large number of experiments studying the broadening and the shift of  $3D-3P$  (818/819 nm) and  $4D-3P$  (568/569 nm) transitions, which are suitable for high pressure lamp diagnostics. However, the data on the broadening and the shift of the  $nS-3P$  ( $n = 5, 6, 7$ ) transitions are important for a better and more complete understanding of the physics and chemistry of high-pressure discharges (sodium-mercury (cadmium) and metal-halide discharges).

## 2. Experiment

A block diagram of the experimental arrangement is shown in Fig. 1. The measurements have been performed using a 400 W "Tungsram" Na-Cd high-pressure lamp (with translucent sapphire burner) in series with a 400 W inductive choke. The inner diameter, the outer diameter and the length of the sapphire burner are 7.6 mm, 9 mm and 110 mm, respectively. The tips of the electrodes are separated 95 mm. The discharge tube was operated vertically. The discharge was driven by a standard 50 Hz AC line source, with the rms value of the discharge current between

2.4 A and 4.2 A. The burner contains a sodium-cadmium amalgam with approximately 75 molar per cent of sodium (sodium rich amalgam [7]). Xenon is also present as a starting gas at a cold gas pressure of 1.3 kPa. The partial pressure of sodium and cadmium during lamp operation is determined by the temperature of the coldest spot of the burner (usually the space behind electrodes). The spectral lines taken in this way represent an average over many periods of the driving voltage, and their shape is mostly determined by the discharge current [7]. The light from the discharge has been analyzed by a medium-resolution monochromator ("K. Zeiss", model SPM-2, 10  $\mu\text{m}$  entrance slit). A photomultiplier (EMI 9558QB) sensitive in the blue-green spectral region has been used for the detection. A linear amplifier with a low-pass electronic filter for the suppression of the high-frequency noise has been used for the signal amplification. The data have been converted by an A/D converter, and stored in a computer for further analysis.

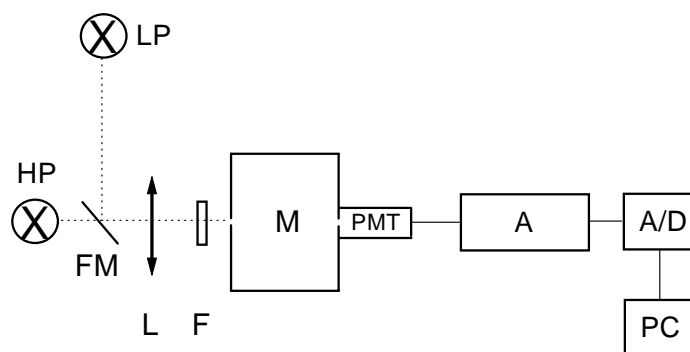

Fig. 1. Experimental arrangement. LP-low pressure lamp; HP-high pressure lamp; FM-folding mirror; L-lens; F-cut off filter; M-monochromator; PMT-photomultiplier; A-amplifier and electronic filtering; A/D-analog-to-digital converter; PC-personal computer.

The measurements of the line-shapes are based on time averaged measured quantities of the 50 Hz AC arc, while calculations made by Bartels' method assume a stationary situation. In principle, one can expect that the plasma features (the electron temperature, the electron density, the density of neutral species) all vary with the phase of the exciting current. However, our recent time-resolved measurements [7,8] show that only electron density really follows the sinusoidal variations of discharge current over one period of driving voltage, whereas the density of neutral particles practically does not change. Since the line profiles of the  $nS-3P$  ( $n = 5, 6, 7$ ) transitions are determined by the resonance broadening of the 3P levels and a small electron broadening and shift of the upper levels [9], the  $nS-3P$  lines are well suited for this averaged way of line shape measurements. The effect of time averaging on measured line-shapes is less than the measuring accuracy and, therefore, does not play an important role.

The electron densities were first determined by the Inglis-Teller method [9], estimating the last discernible lines of the sodium  $nD-3P$  and  $nS-3P$  series. The

electron densities obtained by this simple procedure are known as a rather crude estimate. To increase the accuracy, we used further an improved method, still based on the Inglis-Teller approach, which gives more reliable values of electron density [10]. The data for electron densities given in this paper are a result of this refined procedure. The densities of sodium and cadmium are determined by measuring the spacing between the self-reversed maxima of the sodium resonance lines at 589/590 nm [7,8]. This is an established technique which works well in all high-pressure sodium-mercury discharges [11]. The shifts of the resonance-line blue and red maxima depend on the sodium and cadmium density, respectively. The electron temperatures were determined by fitting the line shapes calculated within the Bartels' method with the experimentally measured line profiles of  $nS-3P$  transitions. Figures 2, 3 and 4 show the line shapes of the  $5^2S_{1/2} - 3^2P_{1/2;3/2}$ , the  $6^2S_{1/2} - 3^2P_{1/2;3/2}$  and the  $7^2S_{1/2} - 3^2P_{1/2;3/2}$  transitions, respectively. All presented

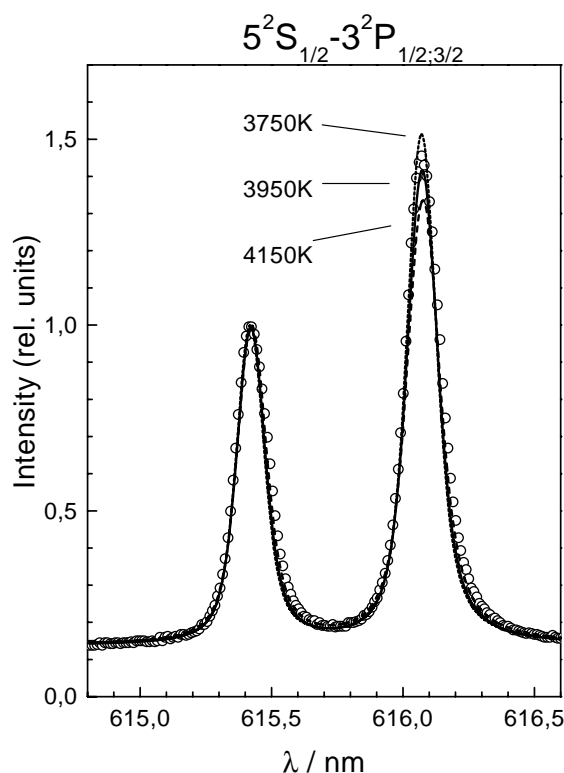

Fig. 2.  $5^2S_{1/2} - 3^2P_{1/2;3/2}$  atomic lines taken at the discharge current of 4 A (hollow circles), simulation calculated within Bartels' method (dotted line - 3750 K, full line - 3950 K, dot-dash line - 4150 K). The average sodium (ground state) density was  $1.5 \times 10^{23} \text{ m}^{-3}$ , the average cadmium (ground state) density was  $30 \times 10^{23} \text{ m}^{-3}$  and the effective electron density was  $1.4 \times 10^{22} \text{ m}^{-3}$ , Stark broadening FWHM  $0.4 \times 10^{-10} \text{ m}$ . We estimate that the overall accuracy of our data is about 40%.

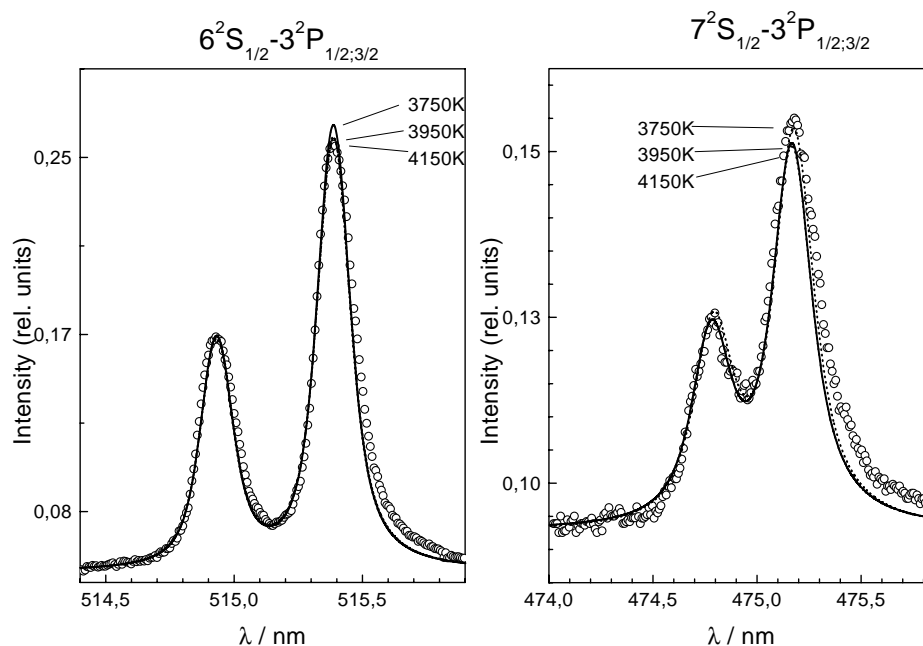

Fig. 3.  $6^2S_{1/2} - 3^2P_{1/2;3/2}$  atomic lines taken at the discharge current of 4 A (hollow circles), simulation calculated within Bartels' method (dotted line - 3750 K, full line - 3950 K, dot-dash line - 4150 K). The average sodium (ground state) density was  $1.5 \times 10^{23} \text{ m}^{-3}$ , the average cadmium (ground state) density was  $30 \times 10^{23} \text{ m}^{-3}$  and the effective electron density was  $1.4 \times 10^{22} \text{ m}^{-3}$ , Stark broadening  $0.8 \times 10^{-10} \text{ m}$ .

Fig. 4 (right).  $7^2S_{1/2} - 3^2P_{1/2;3/2}$  atomic lines taken at the discharge current of 4 A (hollow circles), simulation calculated within Bartels' method (dotted line - 3750 K, full line - 3950 K, dot-dash line - 4150 K). The average sodium (ground state) density was  $1.5 \times 10^{23} \text{ m}^{-3}$ , the average cadmium (ground state) density was  $30 \times 10^{23} \text{ m}^{-3}$  and the effective electron density was  $1.4 \times 10^{22} \text{ m}^{-3}$ , Stark broadening  $1.7 \times 10^{-10} \text{ m}$ .

lines (open circles are experimental data) are measured at a same high discharge current of 4 A (rms value). The data on the Na-Cd plasma at this current are used in the calculations of the line shape (full or dotted lines) and are determined in a separate experiment. The average sodium (ground state) density was  $1.5 \times 10^{23} \text{ m}^{-3}$ , the average cadmium (ground state) density was  $30 \times 10^{23} \text{ m}^{-3}$  and the effective electron density was  $1.4 \times 10^{22} \text{ m}^{-3}$ . We estimate that the overall accuracy of our data is about 40%. The line shape is first calculated within the Bartels' model, and subsequently numerically convoluted with the instrumental profile, represented by a Gaussian of a 0.08 nm FWHM. The instrumental profile has been determined from the measurements of the line shape of the HeNe laser line at 632.8 nm.

### 3. Results and discussion

#### 3.1. Theoretical line profile

The total spectral line profile of sodium  $nS-3P$  ( $n = 5, 6, 7$ ) transitions is influenced by three main broadening mechanisms: Stark broadening (by electrons), the van der Waals broadening (by neutral foreign atoms) and the resonance broadening (by similar atoms) [12]. The shape of an atomic line can be calculated in two different approximations, impact and quasistatic, corresponding to two different interaction pictures. The applications of the impact or the quasistatic approximations yield very different line shapes [9]. However, the impact approximation yields the same, Lorentzian line shape for all broadening mechanisms (resonance broadening, van der Waals broadening, and Stark broadening):

$$P_L(\Delta\lambda) = \frac{\Delta\lambda_{1/2}}{\pi c} \frac{1}{(\Delta\lambda - s)^2 + (\Delta\lambda_{1/2})^2},$$

where the total Lorentzian line width (FWHM) is given by  $\Delta\lambda_{1/2} = (\Delta\lambda_{1/2})_S + (\Delta\lambda_{1/2})_R + (\Delta\lambda_{1/2})_{vdW}$ . It represents the sum of the Stark, the resonance and the van der Waals line widths. The total line shift is also given by  $s = \eta_W (\Delta\lambda_{1/2})_{vdW} + \eta_S (\Delta\lambda_{1/2})_{Stark}$ , where the  $\eta_i$  parameters have a very weak temperature dependence [9].

The Stark-broadened line width is given by [9]

$$(\Delta\lambda_{1/2})_S = 11.37 \frac{\lambda_0^2}{4\pi c} C_4^{2/3} v_e^{3/5} N_e,$$

where  $C_4$  represents the Stark interaction constant,  $v_e$  is the mean electron velocity and  $N_e$  is the electron density.

The resonance line width is given by [9]

$$(\Delta\lambda_{1/2})_R = \frac{\pi\lambda_0^2}{2c} C_3^{Na} N_{Na},$$

where sodium-sodium interaction constant,  $C_3^{Na}$ , depends on the oscillator strength for absorption,  $f_{ik}$ , as  $C_3^{Na} = \frac{\lambda_0}{4\pi\epsilon} \frac{e^2}{4\pi mc} f_{ik}$ . The line widths are calculated using the data for the sodium absorption oscillator strengths given in Ref. [13].

The van der Waals line width is given by [9]

$$(\Delta\lambda_{1/2})_{vdW} = \frac{2.02 \lambda_0^2}{\pi c} (C_6^{NaCd})^{2/5} v^{3/5} N_{Cd},$$

where  $v$  is the relative velocity between sodium and cadmium atoms. The sodium-cadmium interaction constant,  $C_6^{NaCd}$ , depends on the cadmium dipole polarizability,  $\alpha$  [14], as  $C_6^{NaCd} = \alpha e^2 \langle r_k^2 \rangle$ , where  $\langle r_k^2 \rangle$  represents the mean square radius of the

valence electron in the excited sodium state  $k$ . The effective  $C_6$  sodium-cadmium interaction constants used in calculations of the  $5^2S_{1/2} - 3^2P_{1/2;3/2}$ , the  $6^2S_{1/2} - 3^2P_{1/2;3/2}$  and the  $7^2S_{1/2} - 3^2P_{1/2;3/2}$  transition line shapes are given in Table 1.

Table 1. Calculated effective Na-Cd interaction constants for  $n^2S_{1/2} - 3^2P_{1/2;3/2}$  transitions.

Transition	$5^2S_{1/2} - 3^2P_{1/2;3/2}$	$6^2S_{1/2} - 3^2P_{1/2;3/2}$	$7^2S_{1/2} - 3^2P_{1/2;3/2}$
$\lambda(nm)$	615.4/616.1	514.9/515,3	474.8/475.2
$C_6^{NaCd}$ ( $10^{-42} J m^6$ )	2.9	7.6	17.4

On the other hand, the quasistatic approximation for the van der Waals interaction yields the following profile

$$P_{QS}(\Delta\lambda) = \frac{\sqrt{\Delta\lambda_0}}{2\Delta\lambda^{1.5}} \exp\left(-\frac{\pi\Delta\lambda_0}{4\Delta\lambda}\right),$$

where  $\lambda > \lambda_0$  and

$$\Delta\lambda_0 = \frac{\lambda_0^2}{2\pi c} \left(\frac{4\pi}{3}\right)^2 C_6^{NaCd} v^{0.6} N_{Cd}^2$$

represents the characteristic width of the van der Waals profile. There is no contribution in the blue line-wing,  $P_{QS}(\Delta\lambda, \lambda \leq \lambda_0) = 0$ .

Following Stormberg [12], the total line profile can be successfully simulated by convolving the impact line profile (Lorentzian profile,  $P_L(\Delta\lambda)$ ) and the quasistatic line profile (van der Waals profile,  $P_{QS}(\Delta\lambda, \lambda \geq \lambda_0)$ )

$$P_{L-QS}(\Delta\lambda) = \int P_L(\Delta\lambda - \zeta) P_{QS}(\zeta) d\zeta.$$

The convolution integral gives a synthetic, normalized line profile, expressed in a complicated but analytical form [12], convenient for rapid calculations [15]. However, while this result for the synthetic line profile is mathematically correct, it can be questioned from the physical point of view. Presented construction of the resultant synthetic line profile aimed to describe simultaneously the line core and the line wings, suggests that we can also "mix" (or convolve) two broadening mechanisms which are strictly limited: one to the line core (giving the impact line profile), and another to the line wing (delivering the quasistatic line profile). This is certainly not true [9], but justification for the application of this synthetic profile in the line-shape analysis comes from the fact that it smoothly and correctly describes the complete line shape, behaving as an Lorentzian in the line core and in the blue line-wing, and as an exponential in the red line-wing. This approach has been very successfully applied to the analysis of the shape of atomic lines originating in various high-pressure discharges (sodium lines in high-pressure sodium and metal-halide discharge [16], mercury lines in high-pressure mercury discharge [17]).



### 3.2. Bartels' method

Bartels' method [18] is based on the assumptions that the axially symmetric plasma is in a partial local thermodynamic equilibrium (PLTE), the equation of state for ideal gas is fulfilled, the partial pressure of the emitting atoms is constant throughout the plasma column, and that the depletion of the ground state population due to excitation and ionization can be neglected. The population of an excited atomic state is given by the Boltzmann equation

$$N_n(r) = N_0(r) \frac{g_n}{g_0} \exp\left(-\frac{E_n}{kT(r)}\right)$$

where  $g_n$  and  $g_0$  are statistical weights of level  $n$  and of the ground state, respectively. The ground-state atomic density,  $N_0(r)$  is related to the total vapour pressure and the gas temperature via the equation of state

$$N_0(r) = \frac{g_0}{U(T)} \frac{p}{kT(r)},$$

where  $U(T)$  is the partition function of the atom,  $k$  is the Boltzmann constant and  $p$  is the local vapour pressure.  $T(r)$  is the temperature distribution along a radius of the discharge

$$T(r) = T_A - (T_A - T_W) \left(\frac{r}{R}\right)^n.$$

$T_A$  is the axis temperature and  $T_W$  is the wall temperature, whereas  $n = 2$ , assuming a parabolic temperature distribution. Partition function of the atom,  $U(T)$ , is approximately equal to  $g_0$  under high-pressure discharge conditions.

The intensity of a spectral line within Bartels' method is given by

$$I(\nu) = \frac{2h\nu^3}{c^2} \exp\left(-\frac{h\nu}{kT_m}\right) MY(\tau_0, p),$$

where  $\tau_0$  is the optical depth, and the function  $Y(\tau_0, p)$  represents the influence of the optical depth on the peak line intensity, and could be expressed parametrically. The parameters  $M$  and  $p$  describe the inhomogeneity of the plasmas, so that  $p = 1$  corresponds to a homogeneous plasma column, and  $p = 0$  to a completely inhomogeneous source. The energy of the lower level for the line under investigation must satisfy the conditions:  $kT_m \ll E_n$  (pressure broadening) and  $kT_m \ll E_n + 0.5E_i$  (Stark broadening). The function  $M$  must satisfy conditions:  $M = \sqrt{E_n/E_m}$  (van der Waals broadening) and  $M = \sqrt{E_n + 0.5E_i}/\sqrt{E_m + 0.5E_i}$  (Stark broadening).  $E_n$  and  $E_m$  are the energies of the lower and the upper level of the atomic line, respectively, whereas  $E_i$  is the ionization energy. Under our conditions both,  $M$  and  $p$ , are constant within a spectral line.

### 3.3. Comparison of the experimental and calculated line shapes

The simulations shown here are the best fits to the line-shapes measured in the experiment. The line profile is first calculated by the line-shape function  $P_{L-QS}(\Delta\lambda)$  which depends on the broadening mechanisms. This synthetic line shape,  $P_{L-QS}(\Delta\lambda)$ , is used in the Bartels' model to obtain the "true" line shape emitted by the discharge. This line shape is subsequently numerically convolved with the instrumental profile represented by a Gaussian of 0.08 nm FWHM, in order to obtain the profile which can be directly compared with the measured one.

Figure 2 shows the lineshape of the  $5^2S_{1/2} - 3^2P_{1/2;3/2}$  sodium atomic lines at 615.4/616.1 nm taken at a high discharge current of 4 A (rms value). Only a fraction of the numerous experimental points is shown in the figure with the aim to achieve a better presentation of the fit. One can observe that the use of the electron temperature of 3950 K leads to the best fit of the experimental data, clearly visible in the case of the long-wavelength component at 616.1 nm. The overall agreement between experiment and the fit is rather good for the other two close temperatures, too. We can, therefore, estimate that the electron temperature determined in this way (3950 K) has an error of at most  $\pm 200$  K ( $\pm 5\%$ ). Careful inspection of the blue and the red line-wings shows that while the blue wing shows almost perfect agreement, the red wing shows a discrepancy between experimental line shape and the simulated line shape. This asymmetry is even more visible in the case of the  $6^2S_{1/2} - 3^2P_{1/2;3/2}$  lines at 514.9/515.3 nm (Fig. 3) and the  $7^2S_{1/2} - 3^2P_{1/2;3/2}$  lines at 474.8/475.2 nm (Fig. 4), both taken at the same high discharge current of 4 A (rms value). The figures show that the line-shape simulations share the same electron temperature of 3950 K, with an error bar of  $\pm 200$  K.

All three figures show the same pattern: a very good agreement between experiment and simulation for the blue wing(s), and a pronounced asymmetry in the red wing(s). The red asymmetry increases with the increased discharge current (not shown here) and also increases with the main quantum number of the atomic transition, being the strongest for the  $7^2S_{1/2} - 3^2P_{3/2}$  line at 475.2 nm. Although the presence of cadmium produces a red asymmetry, the one demonstrated in Figs. 2 to 4 can not be attributed to the asymmetric broadening by cadmium, because it would require one to two orders of magnitude higher cadmium pressure (compared to the measured one) to reach the observed level of asymmetry.

One can also change the calculated sodium-cadmium interaction constants, but a close match with the experiment (in the red line-wing) would require orders of magnitude higher  $C_6$  constant to reach the observed level of asymmetry (see Fig. 5). Although 5-fold larger  $C_6$  constant produces a calculated profile that apparently looks as a better fit (see Fig. 5), a closer inspection of the difference between the calculated and measured profiles (lower part of Fig. 5) reveals that this introduces an additional near-wing asymmetry in both, blue and red wing. The simulation shown in Fig. 5, based on the original data taken from Fig. 2 (solid line,  $C_6$ , lower part of Fig. 5), shows a clear asymmetry only in the red wings of both lines. So, we believe that excessively high cadmium pressure or an excessively large  $C_6$  constant can not be the cause of the observed red-wing asymmetry.

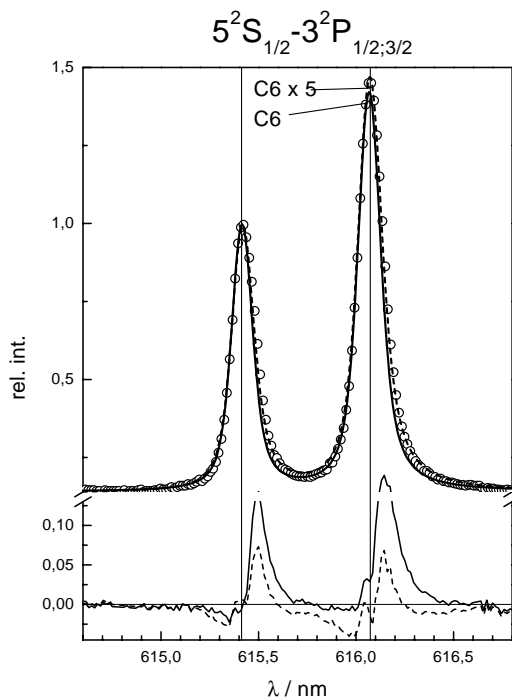

Fig. 5. Upper part –  $5^2S_{1/2} - 3^2P_{1/2;3/2}$  atomic lines taken at the discharge current of 4 A (hollow circles), simulation calculated within Bartels' method (full line, at 3950 K), for two different values of the effective  $C_6$  constant. Lower part – the difference between experimental and calculated profiles for two different effective  $C_6$  constants.

The only parameter neglected so far that can cause a similar effect is the interaction of neutral radiating atom with the ions [9]. In a qualitative picture, this interaction can enhance the red wing of the line involved, since it contributes only to the red wing intensity of the lines we investigate [9]. Measurements and calculations of the ion densities in high pressure discharges, performed by Waszink [19] and van Trigt and Blom [20], show that in high-pressure discharge the ion density on the axis can reach the values of about  $1.5 \times 10^{22} \text{ m}^{-3}$ . That high density could be large enough to produce the effect we observe in our NaCd discharge.

#### 4. Conclusion

We have measured three sodium atomic lines belonging to the  $n^2S_{1/2} - 3^2P_{1/2;3/2}$  ( $n = 5, 6, 7$ ) series. Comparing the measured line-shapes and the calculated ones, we have shown that there exists a residual red asymmetry which can not be attributed to the interaction of the sodium radiating atom in the  $n^2S_{1/2}$  atomic state with its neutral neighbors. Instead, we suggest that this residual asym-

metry is caused by the interaction with ionic species which are present in significant densities in the sodium-cadmium high-pressure discharge.

#### Acknowledgements

This research was supported by the grant JF107/NIST/Veza of the USA-Croatia Joint Fund for Cooperation in Science and Technology and by the Ministry of Science and Technology of the Republic of Croatia.

#### References

- [1] K. Schmidt, *Proc. 6th Int. Conf. Ion Phenomena in Gases*, Paris, 1963, **3** (1963) 323.
- [2] J. J. de Groot and J. A. J. M. van Vliet, *The High-Pressure Sodium Lamp*, Philips Technical Library, Deventer 1986).
- [3] G. Pichler, D. Fijan, D. Veža, J. Rukavina and J. Schlejen, *Chem. Phys. Lett.* **147** (1988) 497.
- [4] G. Pichler, D. Veža and D. Fijan, *Opt. Commun.* **67** (1988) 45.
- [5] D. Azinović, J. Rukavina, G. Pichler and D. Veža, *Fizika (Zagreb)* **22** (1989) 469.
- [6] H. Bartels, *Z. Phys.* **128** (1950) 546.
- [7] T. Bizjak, *Diploma Work* (in Croatian), Dept. of Physics, Univ. of Zagreb, Zagreb (2000).
- [8] T. Bizjak, Ž. Mioković and D. Veža, submitted for publication.
- [9] H. R. Griem, *Spectral Line Broadening by Plasmas*, Academic Press, New York (1974).
- [10] C.-R. Vidal, *JQSRT* **6** (1966) 461.
- [11] P. A. Reiser and E. F. Wyner, *J. Appl. Phys.* **57** (1985) 1623.
- [12] H. P. Stormberg, *J. Appl. Phys.* **51** (1980) 1963.
- [13] J. R. Fuhr and W. L. Wiese, in *CRC Handbook of Chemistry and Physics*, CRC Press, Boca Raton (1996).
- [14] D. Goebel and U. Hohm, *Phys. Rev. A* **52** (1995) 3691.
- [15] A. K. Hui, B. H. Armstrong and A. A. Wray, *JQSRT* **19** (1978) 509.
- [16] H. P. Stormberg and R. Schaefer, *J. Appl. Phys.* **54** (1983) 4338; R. Schaefer and H. P. Stormberg, *J. Appl. Phys.* **57** (1985) 2512.
- [17] H. Skenderović and V. Vujnović, *JQSRT* **55** (1996) 155.
- [18] H. Zwicker, in *Plasma Diagnostics*, ed. W. Lochte-Holtgreven, North-Holland, Amsterdam (1968).
- [19] J. H. Waszink, *J. Phys. D* **6** (1973) 1000.
- [20] C. van Trigt and N. Blom, *JQSRT* **15** (1975) 905.

OBLIK LINIJA NATRIJEVIH PRIJELAZA  $n^2S_{1/2}-3^2P_{1/2;3/2}$  U Na-Cd IZBOJU PRI VISOKOM TLAKU

Mjerali smo natrijeve linije niza  $n^2S_{1/2}-3^2P_{1/2;3/2}$  ( $n = 5, 6, 7$ ) koje nastaju u visokotlačnom izboju u natrij-kadmijevoj plazmi. Određeni oblici linija se uspoređuju s računatima na osnovi Bartelsove metode. Elektronske se gustoće ocjenjuju Vidalovim postupkom (poboljšanom Inglis-Tellerovom metodom), a gustoća natrija i kadmija se određuje odnosom interakcijskih konstanti kvazimolekula natrij-natrij (natrij-kadmij) i pomaka vrhova zbog samoapsorpcije natrijeve rezonantne linije. Pretpostavljamo da su glavni mehanizmi širenja spektralnih linija  $n^2S_{1/2}-3^2P_{1/2;3/2}$  Starkovo širenje (elektronima), vlastito-širenje (neutralnim natrijevim atomima) i van der Waalsovo širenje (kadmijevim atomima). Elektronske su temperature određene Bartelsovom metodom kojom smo načinili prilagodbe eksperimentalno određenim profilima  $n^2S_{1/2}-3^2P_{1/2;3/2}$  linija. Sve linije pokazuju "crvenu" asimetriju koja se ne može objasniti elektronskim širenjem, vlastitim-širenjem ili širenjem stranim atomima. Smatramo da je "crvena" asimetrija uzrokovana interakcijom natrijevih atoma koji zrače s natrijevim i kadmijevim ionima.