

Telemetrijsko istraživanje razlučivanja razine osvjetljenja u pauka *Cupiennius salei*

Šuljić, Ana

Master's thesis / Diplomski rad

2019

Degree Grantor / Ustanova koja je dodijelila akademski / stručni stupanj: **University of Zagreb, Faculty of Science / Sveučilište u Zagrebu, Prirodoslovno-matematički fakultet**

Permanent link / Trajna poveznica: <https://um.nsk.hr/um:nbn:hr:217:485521>

Rights / Prava: [In copyright](#) / [Zaštićeno autorskim pravom.](#)

Download date / Datum preuzimanja: **2024-08-07**



Repository / Repozitorij:

[Repository of the Faculty of Science - University of Zagreb](#)



Sveučilište u Zagrebu
Prirodoslovno-matematički fakultet
Biološki odsjek

Ana Šuljić

**Telemetric study of brightness discrimination in nocturnal
hunting spider *Cupiennius salei***

Diplomski rad

Zagreb, 2019. godina

*Ovaj diplomski rad izrađen je na Zavodu za neurobiologiju Sveučilišta u Beču,
pod vodstvom Dr. sc. Axela Schmida, prof. i Dr. sc. Zorana Tadića, izv.prof.
Predan je na ocjenu Biološkom odsjeku Prirodoslovno-matematičkog fakulteta
Sveučilišta u Zagrebu radi stjecanja zvanja prof. biologije*

TEMELJNA DOKUMENTACIJSKA KARTICA

Sveučilište u Zagrebu
Prirodoslovno-matematički fakultet
Biološki odsjek

Diplomski rad

Telemetrijsko istraživanje razlučivanja razine osvjetljenja u pauka *Cupiennius salei*

Ana Šuljić

Rooseveltove trg 6, 10000 Zagreb

Istraživala sam promjene u razini aktivnosti očnog mišića pauka *Cupiennius salei* kao odgovor na razlučivanje različitih razina osvjetljenja pokretnih podražaja. Kod ovih pauka dolazi do povećanja mišićne aktivnosti u glavnim očima kada su pokretni podražaji opaženi sekundarnim očima. Aktivnost dorzalnog očnog mišića mjerila sam malim telemetrijskim uređajem. Registrirano je statistički značajno povećanje u mišićnoj aktivnosti oka kao odgovor na opažanje podražaja. Na taj način odredila sam najmanju razliku osvjetljenja između podražaja i pozadine koju je pauk mogao razlučiti. Izračunala sam najmanje Weberove kontraste koji su nakon određene razine osvjetljenja pozadine postojani- oko 0.17 za podražaje svjetlije od pozadine ili 0.08 za one tamnije. Sposobnost razlučivanja razine osvjetljenja je statistički značajno bolja s tamnijim nego svjetlijim podražajima. Izračunala sam Weberovu frakciju od 0.15 za tamnije i od 0.65 za svjetlije podražaje.

(54 stranica, 16 slika, 2 tablice, 66 literaturnih navoda, jezik izvornika: engleski)

Rad je pohranjen u Središnjoj biološkoj knjižnici

Ključne riječi: *Cupiennius salei* / razina osvjetljenja / jedno-kanalna telemetrija

Voditelj: Dr. sc. Zoran Tadić, izv. prof.

Ocjenitelji: Dr. sc. Božena Mitić, prof.

Dr. sc. Damir Sirovina, v. pred.

Zamjena: Dr. sc. Tatjana Bakran-Petricioli, izv. prof.

Rad prihvaćen: 5. rujna 2019.

BASIC DOCUMENTATION CARD

University of Zagreb
Faculty of Science
Division of Biology

Graduation Thesis

Telemetric study of brightness discrimination in nocturnal hunting spider *Cupiennius salei*

Ana Šuljić

Rooseveltova trg 6, 10000 Zagreb

I investigated changes in the eye muscle activity of the spider *Cupiennius salei* as a response to brightness discrimination of moving stimuli. These spiders enhance eye muscle activity in their principal eyes when moving stimuli are detected in the secondary eyes. The activity of the dorsal eye muscle was measured using a small telemetric unit. I registered a significant increase in eye muscle activity as response to perception of stimuli. In this way I determined the just noticeable brightness difference between the stimulus and the background which the spider could still see. The calculated minimal Weber contrasts are constant after a certain background luminance- around 0.17 for stimuli which are brighter than the background, or 0.08 for darker stimuli. The brightness discrimination ability is significantly better with darker than with brighter stimuli. The Weber fraction was calculated as 0.15 for darker stimuli and 0.65 for brighter stimuli.

(54 pages, 16 figures, 2 tables, 66 references, original in: English language)

Thesis deposited in Central biological library

Key words: *Cupiennius salei* / brightness discrimination / single –channel telemetry / luminance

Supervisor: Dr. sc. Zoran Tadić, Asst. Prof.

Reviewers: Dr. sc. Božena Mitić, Prof.

Dr. sc. Damir Sirovina

Replacement: Dr. sc. Tatjana Bakran-Petricioli, Asst. Prof.

Thesis accepted: September 5th 2019

Table of Content

1. INTRODUCTION	1
1.1. Role of <i>Cupiennius salei</i> in science	2
1.2. Morphology and taxonomy	2
1.3. Habitat and life history	3
1.4. Mechanical senses	5
1.5. Visual senses	6
1.5.1. Morphology of the eyes	6
1.5.2. Eye properties.....	9
1.5.3. Eye muscles	10
1.5.4. Muscle movements	12
1.5.5. Behavioral importance of vision	14
1.5.6. Spectral sensitivity	15
1.5.7. Visual fields	16
1.6. Brightness discrimination.....	17
1.6.1. Brightness discrimination in other species.....	18
1.7. Aim.....	20
2. MATERIALS AND METHODS	21
2.1. Experimental animal.....	22
2.2. Single-channel telemetric device.....	22
2.3. Visual stimulation.....	23
2.4. Stimuli.....	24
2.5. Preparation of the experimental animal.....	27
2.6. Experimental setup.....	29
2.7. Signal processing.....	31
2.8. Data analysis.....	31

3. RESULTS.....	33
3.1. Eye muscle potentials.....	34
3.2. Establishing the perception of moving stimuli.....	35
3.3. The just noticeable brightness difference.....	35
3.4. Increases in mean frequency for a single background.....	37
3.5. Calculation of Weber fractions.....	38
4. DISCUSSION.....	41
4.1. Brightness discrimination in the context of vision.....	42
4.2. Comparison with jumping spiders.....	43
4.3. Comparison with vertebrates	44
5. CONCLUSIONS.....	46
6. REFERENCES.....	48

1. INTRODUCTION

1.1. Role of *Cupiennius salei* in science

Compared to insects and crustaceans, arachnids have long been neglected by neurobiological and behavioural studies. There is one species that escapes this anonymity- *Cupiennius salei* (Keyserling 1877), the only spider that can be considered a model organism for sensory biology, neurobiology and neuro-ethology (Uetz and Roberts 2002). In these studies, as well as studies on arachnid physiology, this Ctenid spider fills a role *Drosophila melanogaster* (Meigen 1830) fills in genetics and evolution.

Cupiennius was first described in the 1877 Proceedings of the Zoological Botanical Society of Vienna by Keyserling (a nobleman, social Darwinist and philosopher). The holotype has since been lost, but the description was so precise that that there is no doubt of its identity (Barth 2002).

Before achieving the peak of its biological fame, the species *Cupiennius salei* first became a point of interest in a marketplace. Three impressively large female spiders were found in Munich's central indoor marketplace, transported from Central America in a shipment of bananas. After causing some perturbation among market vendors they came into the hands of a doctoral candidate at the University Institute of Zoology, Mechild Melchers. Melchers realized that the spider could be an ideal model for biological research because of its large size and relatively inactive behavior. She also managed, with relative ease, to breed the spiders in a laboratory in impressive numbers. From her initial 1963 publication on its biological characteristics, *Cupiennius* has become the most studied species of spider (Melchers 1963; Barth 2002).

1.2. Morphology and taxonomy

Cupiennius salei is a large venomous spider with distinct sexual dimorphism. The females, larger than the males, measure up to 3.5 cm in body length, with a legspan of 10 cm. The dorsal side of the body is brown with lighter spots on the abdomen and dark longitudinal stripes on the carapace. The ventral side is orange. Males measure up to 2.5 cm and while they have roughly the same legspan as the females, they are much lighter in colour and have conspicuous palpal bulbs (Barth 2002).

Cupiennius belongs to the family of wandering spiders (Ctenidae). Up until now, nine species of the genus were described (Lachmuth et al. 1984; revision in Barth and Cordes 1998).

1.3. Habitat and life history

Commonly called American wandering spider or tropical wandering spider, *Cupiennius* is the native of Central and northern parts of South America; most commonly it is found in the tropical rainforests of Mexico, Guatemala and Honduras (Barth 2002).

As a wandering spider, it does not build webs for the catching of prey, but instead relies on its venom and a sit-and-wait strategy for hunting. A generalist, its victims range from insects to small vertebrates. Most often on the menu are cockroaches, earwigs and crickets, but it is not unusual to see *Cupiennius* with a frog in its chelicerae (Melchers 1967).



Figure 1. *Cupiennius salei* catching a cockroach. The reflective tapetum in the left PM eye is visible (picture taken from the website www.diark.org).

Cupiennius salei has a marked day-night activity rhythm (Barth and Seyferth 1979; Seyferth 1980; Schmitt et al. 1990) and is only active at night. During the day it shelters on the under leaves of monocotyledons (bromelias, agavas, bananas; mainly from the families Amaryllidaceae, Araceae, Bromeliaceae, Liliaceae and Musaceae) (Barth and Seyferth, 1979; Barth et al. 1988). These plants have tough, unbranched leaves that provide a secure and shady shelter at their base (Seyferth 1980). Other than offering hiding places, plants in this group serve as a particularly good conduit of the vibrations that are so important in a spider's life (for instance courtship vibrations are commonly transmitted through the dwelling plants of the spider). It is possible that the organization of the monocotyledon vessels has a crucial impact in the way vibration is carried by the plant substrate (Barth et al. 1988; Barth 2002)

At light levels of 15 lx, the spider leaves its retreat to hunt for prey or look for mates. It however first sits motionless near its shelter until it gets completely dark (light levels of 0.1 lx) when it becomes active. Its maximum activity is reached 2-3 hours after dark (Seyferth 1980; Schmitt et al. 1990).

Under laboratory conditions females make cocoons with around 1,500 embryos each, every three to four weeks. The embryo is typically 1.3 mm in diameter. The complete life cycle from fertilized egg to mature adult takes between 9 and 12 months. In the laboratory the larvae are generally fed with fruit flies and the adults with flies or crickets. They they go through eleven moults to become adult and become reproductively mature after the final moult (Barth 2002).

1.4. Mechanical senses

The choice of the right habitat is of great importance for animals. The performance of sensory organs must then be evaluated in the context of its habitat and as a link between the environment and the spider's behavior. The life of *Cupiennius* is especially dependent on the plants on which it resides and the hunting grounds they provide (Barth et al. 1988), and so the technical acuity of sense organs mirrors the spider's habitat.

Since the Devonian period evolution has endowed spiders with an impressive assortment of mechanical senses responding to a broad spectrum of stimuli: from air currents and vibrations to deformations of the exoskeleton and gentle touches.

The role of mechanoreception in the behavior of most spiders is correspondingly diverse, with the familiar example of responding to vibrations when a pray animal is trapped in its web. In hunting spiders' senses responding to airflow stimuli can be so accurate that they are known to jump in the air at an insect flying by (Barth 2002).

No exception to this general rule, *Cupiennius salei* can detect air currents, deformations of the exoskeleton and substrate vibrations. With more than 3000 sensors in its exoskeleton, lyriform organs and vibration receptors near leg joints, the spider's body is built to detect anything in its path (Albert et al. 2001; Barth 2002; French et al. 2002, Hergenröder and Barth 1983). Behavioral responses that use mechanoreception include courtship and prey capture. In fact, pre-copulatory behavior is mediated solely by pheromones and vibrations, with no evidence of vision playing a role in the signaling (Barth and Seyfarth 1979; Bath 1992). Substrate vibrations (Hergenröder and Barth 1983; Barth et al. 1995) and airflow stimuli (Melchers 1963; Hergenröder and Barth 1983; Barth et al. 1995) can both independently elicit

prey capture in *Cupiennius*. The spiders are in fact more than able to catch its prey with blindfolded eyes (Barth et al. 1995), and it has therefore been assumed that vision plays a very minor, if any, role in *Cupiennius*'s life.

Combined with the fact that *Cupiennius salei* is only active during nighttime, it is no wonder that its vision has only comparatively recently come into focus of research. Behavioral observations in the field suggested that the only effect visual stimuli might have is to interfere with prey capture. But for this hypothesis, the eyes, when finally tested, turned out to be too good.

1.5. Visual senses

Across the taxon, spiders do not rely only on mechanical senses. Visually guided spiders like Salticidae and Dinopidae have superior eye designs (Land 1985; Blest and Land 1977). Broadly speaking, we can expect impressive vision in hunting spiders (Salticidae, Lycosidae, Thomasiidae and Sparassidae) whereas orbweavers have comparatively poor vision (Barth 2002). A Ctenidae, *Cupiennius* is both taxonomically and behaviorally related to the hunting Lycosidae. They also show similarities in eye structure, which first lead scientists to have a closer look at *Cupiennius* vision, now proved to be much more impressive than first assumed.

1.5.1. Morphology of the eyes

Cupiennius, like most spiders, has 4 pairs of eyes. Unlike any other genus with similar eye arrangement, all 8 eyes of the genus *Cupiennius* are circular. They are arranged in 2 curved rows on the prosoma: 2 median and 2 lateral pairs (Land and Barth 1992). Accordingly, they are called anterior median and anterior lateral eyes; posterior median and posterior lateral. (In further text: AM, AL, PM and PL respectively). The eyes are of two types also morphologically: 1 pair of principal (AM) and 3 pairs of secondary eyes (AL, PM, PL) (Foelix and

Choms 1992). In terms of size, the PM eyes are the largest, the PL slightly smaller, then AM and finally AL (Land and Barth 1992).

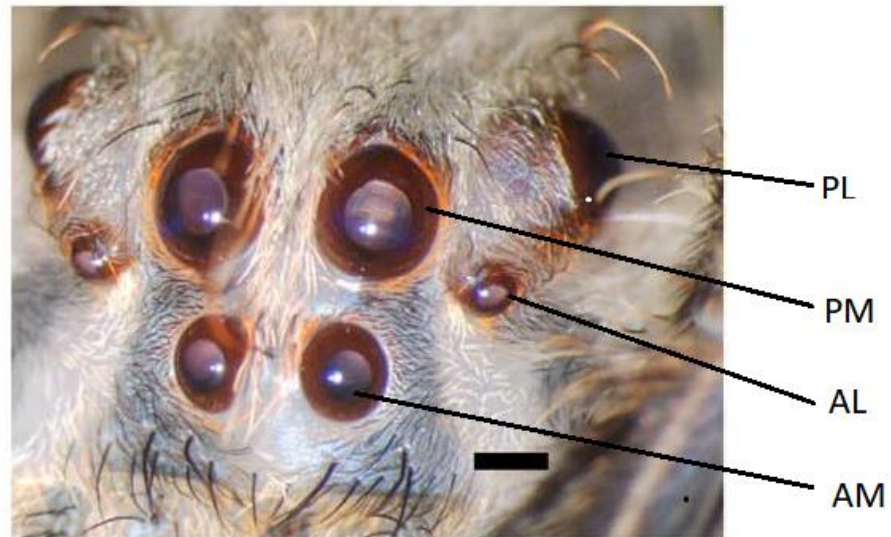

Figure 2. Eyes of *Cupiennius salei*. They are arranged in two strongly curved rows, the AM and AL eyes in front of the PM and PL eyes. AL – antero-lateral, AM – anteromedian, PL – postero-lateral, PM – postero-median (picture adapted from Fenk et al. 2010).

The principal eyes have everted photoreceptor cells- their rhabdoms are oriented towards the light. Rhabdoms of the secondary eyes are inverse (like the eyes of vertebrates) (Grusch et al. 1997). They point backwards away from the incident light, towards a reflective tapetum (which the principal eyes lack) in the back of the eye tube (Land 1985). This gridiron tapetum layer is built up of layers of guanine crystals in parallel strips, rather like a double ladder array. Each tapetal strip supports two rows of receptors. The part of the rhabdomeral cell containing the nuclei is closest to the lens. This means that the receptive section of the cell receives light both before and after reflection from the tapetum, effectively doubling the length of the rhabdoms (Land and Barth 1992).

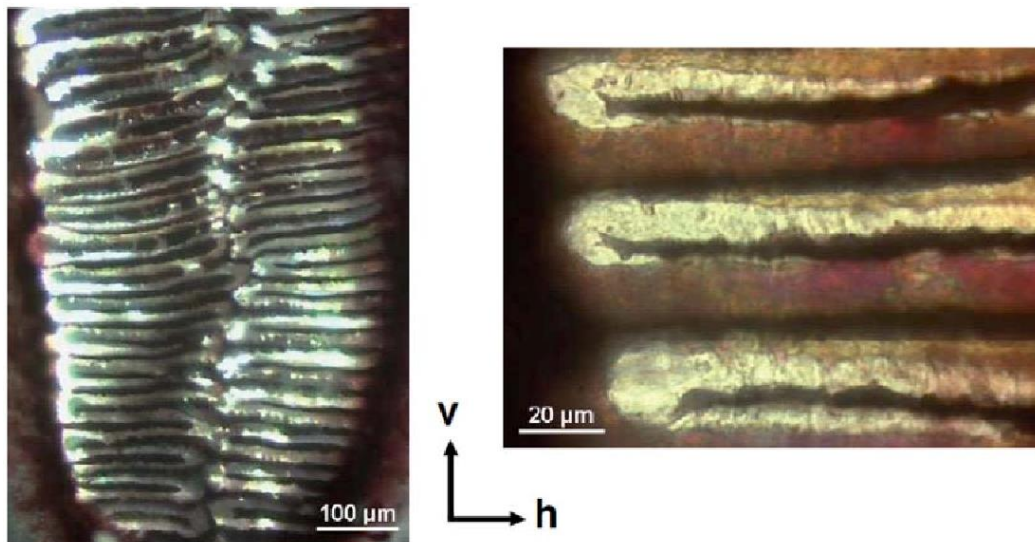

Figure 3. Light micrographs of a PM eye retina. On the left side a grid-shaped tapetum can be seen. The greenish blue tint is the guanine crystals reflecting light through the photoreceptors. On the right side three tapetal strips are shown. One tapetal strip holds two rows of photoreceptors, the axons of which leave the retina (Land and Barth, 1992). The arrows indicate the horizontal (h) and vertical (v) axis of the tapetum with respect to the body axis (picture taken from Fenk 2011).

The eyes also differ in evolutionary origin. The principal eyes derive from an ancestral pair of lens eyes, and secondary from decomposed compound eyes (Paulus 1979).

All eyes have a cuticle cornea and lens and a cellular glass body. The retina is a single layer of photoreceptor cells, the axons of which merge and form visual nerves. These leave the eye cup and proceed to the visual ganglia (Grusch et al. 1997).

If we look at the centres in the brain that receive input from the eyes and process it, the size and the structure reinforce the impression of a developed sense of vision. In spiders the actual brain is almost completely devoted to vision, receiving only the optic nerves and containing only the optic ganglia and some association centres (Strausfeld and Barth 1993).

The distinction made between principal and secondary eyes continues in the brain. The two types of eyes each have their own visual pathway, with two separate sets of neuropil regions (Strausfeld and Barth 1993; Strausfeld et al. 1993). This is an instance of parallel processing of the visual information- the secondary eyes are specialized for viewing the horizontal

movement of objects whereas the principal eyes are suitable for the detection of shape and texture (Land 1971,1985; Schmid 1998; Neuhofer et al. 2009).

1.5.2. Eye properties

F numbers of the lenses of *Cupiennius* eyes range between 0,58 and 0,74. This suggests bright images and a reasonably well-developed spatial resolution. The human eye has a maximal F-number of 2.1. Compared with the PM eyes of *Cupiennius salei* with an F-number of 0.7, this implies that the image of a surface at a given luminance on the retina is roughly 9 times brighter than the image in humans. The absolute corneal illuminance threshold was found to be below 0.01 lx (Barth et al. 1993).

The inter-receptor angles determine the anatomical limit of spacial resolution (Land 1985). In *Cupiennius* they are between 0.9 and 3.6 degrees (along the rows they form). The resolution of the posterior eyes is the best with inter-receptor angles of about 1 degree along the rows, and 2-3 degrees in the vertical direction. The AM eyes have a inter-reception angle of about 3 degrees and the AL eyes have the poorest resolution (Land and Barth 1992).

All this indicates that the eyes can see at very low intensities, especially secondary eyes with their rhabdomeres, optical isolation of the photoreceptors by screening pigment, and the presence of the tapetum.

Another thing that contributes to the eyes sensitivity is the large rhabdom occupation ratio (40%-65%). For comparison, in night-active moths (Sphingidae) the rhabdomeres occupy 60% of the retinal area, whereas the proportions in day-active species is only 10-25% (Eguchi 1982).

The rhabdom occupation ratio changes in a day/night rhythm as seen in other arthropods (Nässel and Waterman 1979; Blest 1978). During the day, the rhabdomeres of the *Cupiennius'* eyes are largely dismantled: only two hours after the light period has begun, 80% of the microvillar membrane area has disappeared (Grusch et al. 1997). This is consistent with a night-active animal.

1.5.3. Eye muscles

The number of eye muscles generally correlates with the spider's lifestyle- most web weaving spiders have only 1 dorsal muscle, and hunting spiders have at least 2 (Widmann 1908). The main function of the muscles is to shift the retina by deforming the elastic eye tube.

The retina of the *Cupiennius* AM eyes is movable by contractions of 2 muscles – the dorsal and ventral eye muscles (Kaps and Schmid 1996). This movement allows for a deflection of 15 degrees of the visual field. The retinae of the 6 secondary eyes cannot be moved. (Barth 2002)

The dorsal muscle of the AM eyes is attached to the exoskeleton in between the two PM eyes and runs the dorso-lateral surface of the AM eye tube. It's 600 μm long, made up of 15-18 striated muscular fibres and 300 μm wide at its ventral insertion point on the eyetube (it fans out from 50 μm width at its starting point). The ventral muscle inserts at the inner surface of the clypeus and the ventro-lateral surface of the eye tube. It consists of 20-22 striated fibers and is 650 μm long and 330 μm wide at the point of insertion (Kaps and Schmid 1996).

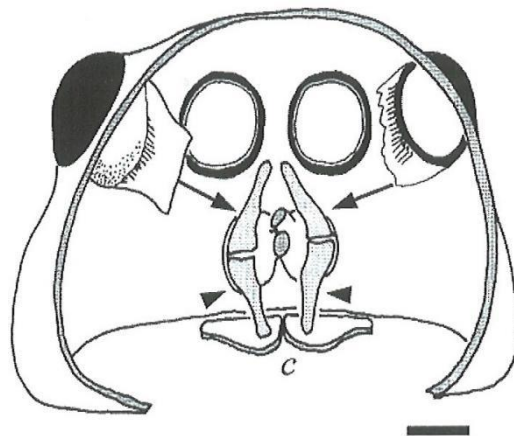

Figure 4. Position of the two muscles of the AM eyes (principal eyes) of *Cupiennius Salei*. Inside view of anterior region of prosoma; dorsal and ventral eye muscles attach on the AM eyes (picture taken from Kaps and Schmid 1996).

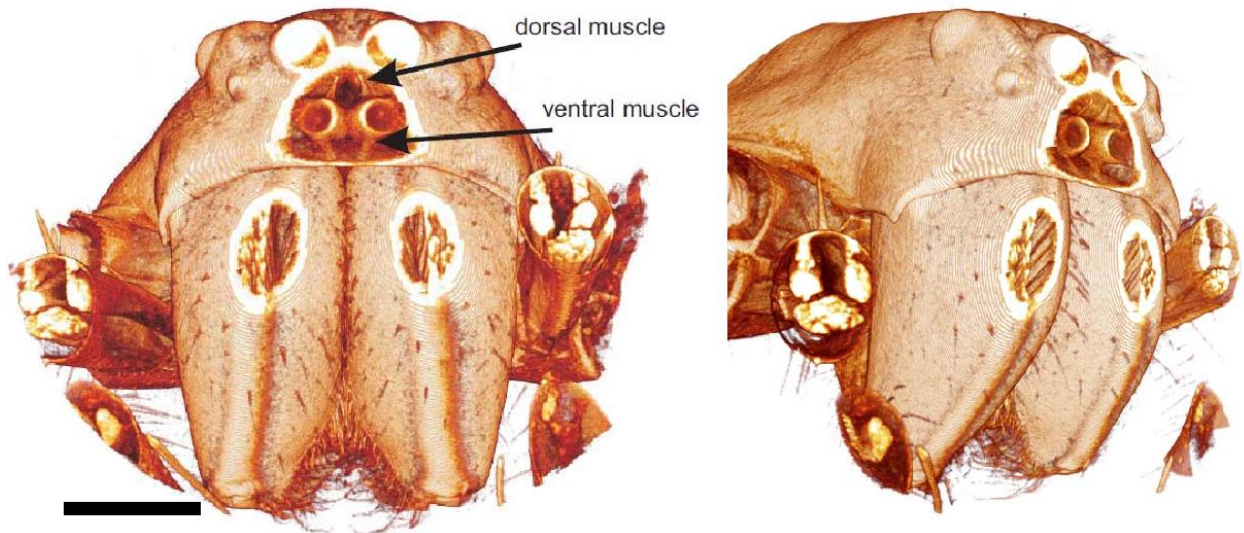

Figure 5. Micro CT recording of the prosoma of *Cupiennius salei*. The virtual opening in the reconstruction reveals the arrangement of the dorsal and ventral eye muscles (picture taken from Fenk 2011).

Each of the two pairs of eye muscles is innervated by a motor nerve. It consists of four axons and splits into two branches shortly before reaching the cup. A dorsal branch with only one thick ($12\ \mu\text{m}$ in diameter) axon runs to the dorsal eye muscle. The ventral branch contains the remaining three axons ($8\text{-}10\ \mu\text{m}$ in diameter) and runs along the wall of the eye cup to the ventral eye muscle (Barth 2002).

Contractions of the muscles are counteracted by the passive elastic restoring force of the eye tube and eye muscles. The medially directed action of both eye muscles does not allow active movements of the eye tube in any lateral direction. The direction of the gaze can be shifted only medially. After active displacement of the retina, the elasticity of the eye tube and the eye muscles passively moves the eye tube back to its resting position (Kaps and Schmid 1996).

The activity patterns of the dorsal and ventral muscles are completely different. The dorsal muscles fire spontaneously (they have a mean resting frequency of around 12 Hz) After mechanical (or visual) stimulation (for example air puffed on the leg stimulating the trichobothria) this frequency increases. Ventral Eye muscles are not spontaneously active and action potentials can only be elicited by mechanical stimuli (their frequency depends on the modality and intensity of the stimulus) (Kaps and Schmid 1996).

The muscles of the 2 AM eyes are not synchronously active- correlating neither for the occurrence, nor the direction of the movement (Kaps and Schmid 1996).

1.5.4. Muscle movements

Animals with good vision usually have an established repertoire of eye movements. In the main they include stable fixations with fast saccades that shift the direction of the gaze. The main reason for keeping gaze still during fixations is the need to avoid the blur that results from the long response time of the photoreceptors. Other reasons for these movements is the need to see the motion of small objects against a stationary background (pursuit of prey or mate) and to prevent contamination of the translational flow-field, by which a moving animal judges its heading and the distance of objects. A common strategy in many walking species is to use small, frequent eye movements to prevent adaptation when perceiving stationary targets (Land 1999).

Taking into account the previously described differences in activity of the two eye muscles we can distinguish two types of eye movements in *Cupiennius salei*:

1. **Spontaneous microsaccades** are short (80 ms duration), jerky movements which occur as the result of the contraction of the dorsal eye muscle only, at a frequency of about 12 Hz. The retina twitches recurrently 2-4 degrees in the dorso-median direction. As the angle matches the 3 deg. inter-receptor angle in the AM eyes, microsaccades can be interpreted as a mechanism to prevent the receptor cells from adapting to a static image by slightly shifting the visual field in a ventral direction (Kaps and Schmid 1996). They allow the spider to form an image of the stationary surroundings. Between the retinal movements stationary stimuli probably disappear from the field of view because the visual cells adapt, as a result of which moving objects stand out from the background.

2. **Induced eye movements or saccades** are caused by the contraction of both the dorsal and ventral eye muscles (Kaps and Schmid 1996). They deflect the visual field laterally- the amplitude of these movements can go up to 15 degrees and their direction varies on the activity of the 2 independent eye muscles. Their duration is between 100-500 ms, and induced muscle activity increases in response to mechanical stimulation before locomotion (Kaps 1998; Trischler 2003), or in response to visual stimulation (Kaps and Schmid 1996).

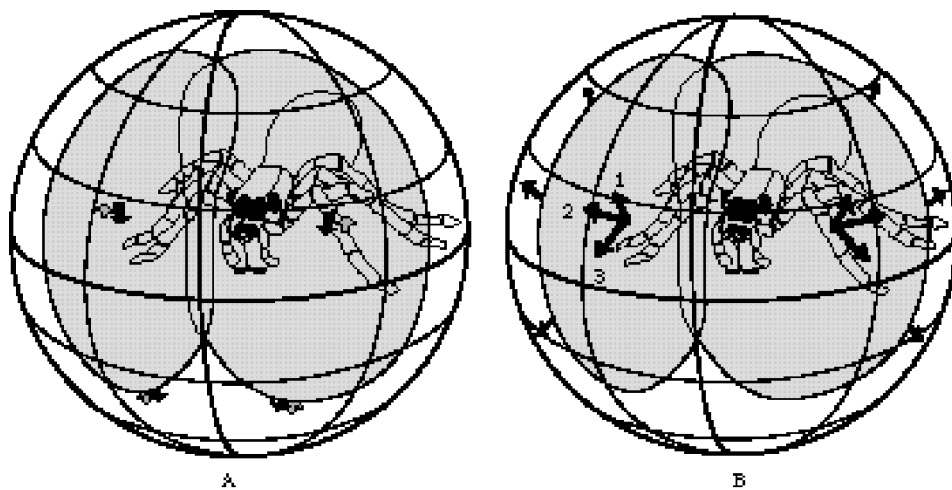

Figure 6. The visual fields of the AM eyes of *Cupiennius salei* (based upon the description of Land and Barth, 1992) projected onto a globe. The black arrows indicate the direction and extent of the shifts of visual fields caused by active retinal movements. (A) Spontaneous microsaccades shift the visual fields only in a ventral direction. (B) Induced movements can shift the visual fields in a dorso-lateral (1), lateral (2) or ventro-lateral (3) direction (picture taken from Kaps and Schmid 1996).

The principal eyes with their movable retina are used for the processing of shapes and discrimination of stationary objects (Schmid 1998) and only the secondary eyes are responsible for the detection of moving objects (Neuhofer et al. 2009). This is in accordance with the results of neuroanatomical investigations of the two different visual pathways of *Cupiennius salei* (Strausfeld and Barth 1993; Strausfeld et al. 1993). The secondary eyes serve as a second visual information channel with the function of providing information about the

movement of objects. This fact is also indicated by the overlap of the visual fields of the AM and the PM eyes (Land 1985; Land and Nilsson 2002).

In its natural habitat the spider often spends hours without moving. In this motionless state spontaneous microsaccades would enable the spider to see non-moving objects and structures without the need for locomotion. At the same time the secondary eyes, which do adapt, would provide the spider with additional optical information regarding movement. This retinal adaptation of the secondary eyes could aid prey detection, because a moving target would 'pop out' even against a leafy background. This two-channel visual input might be highly advantageous for the hunting spider (Kaps and Schmid 1996).

The principal eyes of the spider move involuntarily when objects are moving within the visual field of a secondary eye (Neuhofer et al. 2009). The changes in the eye muscle activity of the principal eyes can therefore be taken as an indicator for the perception of motion.

1.5.5. Behavioral importance of vision

The size and structure of the visual centers in the brain (Strausfeld et al. 1993; Strausfeld and Barth 1993) together with the anatomy of the eyes suggest an important influence of the visual system in some behavioural contexts.

In behavioural studies *Cupiennius salei* was shown to be able to distinguish vertical from sloped objects (Schmid 1998) and to switch the mode of locomotion when the light is turned off (Schmid 1997).

Schmid (1997) also discovered that *Cupiennius* walks straight to the targets if its eyes are uncovered, and its walks are undirected if the eyes are covered with wax- this is therefore a visual response. *Cupiennius* also showed a clear preference towards vertical bar stimuli. This, together with observations in the field, makes us suppose that *Cupiennius* males in particular, while wandering around at night, use their visual sense to locate the stems of monocotyledons where they can find females and prey. None of its other senses are appropriate for this use.

We also know that attack behavior is triggered by 3 sensory modalities- substrate vibrations (Hergenröder and Barth 1983; Barth et al. 1995), airflow stimuli (Melchers 1963; Hergenröder and Barth 1983; Barth et al. 1995) and visual cues (Fenk, Hoinks and Schmid 2010).

Fenk, Hoinks and Schmid (2010) showed for the first time that computer generated visual stimuli, presented on a screen can also elicit attack behavior in *Cupiennius salei* (abrupt approaches). These results indicate that the spiders could use only visual information for hunting and aggressive defense behavior. In the experiment dark targets on bright backgrounds were more efficient stimuli than bright targets on dark backgrounds.

1.5.6. Spectral sensitivity

As Orlando and Schmid's (2010) study shows, *Cupiennius salei* are colour blind although intracellular recordings from photoreceptor cells show 3 photoreceptor types with spectral sensitivity maxima in the blue (480 nm), green (520 nm) and UV (340 nm) (Walla et al. 1996). The blue and green cells show also secondary peaks in the UV (at 340-380 nm). In the PM, PL and AM eyes, the majority of the cells are the blue and green photoreceptor cells and are present in roughly equal numbers. In the AL eye the green cells are prevalent. UV cells were only found in the secondary eyes, but were found only once in each of them. Because of the low number of UV cells found, it can be assumed, either that they are uniformly distributed but their number is very low, or that they are concentrated in parts of the retina difficult to access by electrodes (Walla et al. 1996).

A ERG-analysis has found that the wavelengths seen by the eyes of the *C. Salei* range between 300-680 nm. Maximum sensitivity is at 520-540 nm, there is a small shoulder at 480 nm and a secondary sensitivity peak at 340-360 nm (Barth et al. 1993). This means the main sensitivity is in the green, the secondary peak in the UV and a small shoulder in the blue spectrum (Zopf et al. 2013)

The light reflected from plants is mainly in the wavelengths above 450 nm and is perceived as green and yellow light (Menzel 1979) so this is an obvious connection with the spider's ecology. The blue cells are important for seeing at night or in dim light. However it is still

unknown what UV cells are good for and if *Cupiennius* uses them behaviorally. Light coming directly from the moon does contain short wavelength components (below 450 nm) (Menzel 1979), but it would be unusual to use UV cells to detect this, when the blue and green cells already enable the *Cupiennius* to see by night so well. There are also no ultraviolet reflection patterns on the *Cupiennius* spider itself that would play a role in signalling (Barth 2002).

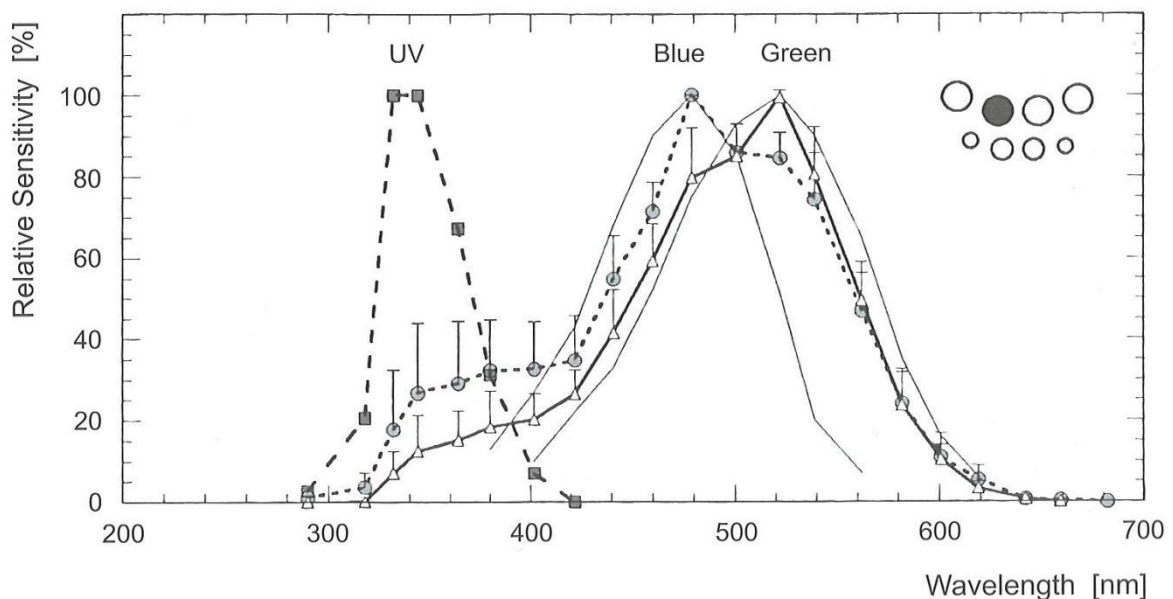

Figure 7. Mean spectral sensitivity of single photoreceptor cells in the PM eye of *Cupiennius salei*. Spectral sensitivity maxima in the blue (480 nm), green (520 nm) and UV (340 nm) as well as secondary peaks of the blue and green cells in the UV region (at 340-380 nm) are shown (picture taken from Walla et al. 1996).

1.5.7. Visual fields

The fields of view of the PM and PL eyes together cover almost the entire upper hemisphere and extend about 40 degrees below the horizon. There is a 5-20 degree gap between the fields of those two eyes. The elongated shape of the visual field of the PM eyes is the same as that of their retinas. The AL eyes look downward, at an area just in front of the chelicerae. Their visual field is small and overlaps with the lower regions of the PM and PL fields. The visual field of the AM (principal) eyes roughly corresponds to that of the PM eyes. That is, the AM and PM eyes all look in the same direction which indicates that they have different functions as already discussed (Land and Bath 1992) .

Visual fields of the individual eyes have no important binocular overlap (Land and Bath 1992).

1.6. Brightness discrimination

Colors have the qualities of hue, saturation and brightness. Brightness is the achromatic aspect of color (hue and saturation are its chromatic aspects). Brightness can also be defined as the perception elicited by the luminance of a visual stimulus. Luminance is a photometric measure of the luminous intensity per unit area of light travelling in a given direction. It describes the amount of light that passes through or is emitted from a particular area, and falls within a given solid angle. Luminance is often used to characterize emission or reflection from flat surfaces. The luminance indicates how much luminous power will be detected by an eye looking at the surface from a particular angle of view. It is thus an indicator of how bright the surface will appear (Kelber, Vorobyev and Osorio 2003).

Chromatic and achromatic signals are useful for different purposes. This means that when achromatic cues are used, such as for motion detection, chromatic signals are disregarded in other words motion detection is color blind (Orlando and Schmid 2010) As colour vision, in association with moving targets, is missing, brightness discrimination ability should be researched in regards to moving target discrimination. Blest (1985) found that the prey capture sequence can be elicited by stimuli whose shape is quite different than normal prey, therefore it seems that prey capture is mainly guided by the luminous contrast of stimulus against background.

To be able to cross compare the results from brightness evaluation studies between species, the relative difference threshold or Weber fractions are calculated. Weber's law states that the relation between the intensity of the starting stimulus (L) and the just noticeable intensity difference (ΔL) is a constant as long as the standard intensity is not close to the detection threshold. The greater the magnitude of the starting stimulus, the greater is the just noticeable difference as expressed in the formula

$$\Delta L/L=k$$

where L is the luminance of the starting stimulus, ΔL is the just noticeable luminance difference threshold and k is the relative difference threshold- the Weber fraction (Geisbauer et al. 2004; Huang et al. 2002). Weber's law does not apply to very low and very high stimulus intensities.

1.6.1. Brightness discrimination in other species

Only relatively few animals have been investigated with respect to brightness discrimination, all using very different evaluation methods as well as different ambient illumination levels which complicates comparison of the data.

Busch and Dücker (1987) tested 2 species of fur seal, *Arctocephalus pusillus* (Schreber 1775) and *Arctocephalus australis* (Zimmerman 1783) with similar results for both species. Griebel and Schmid (1997) calculated the Weber fraction from this data to be around 0.30.

Griebel and Schmid (1997) also conducted a brightness discrimination test with the West Indian manatee (*Trichechus Manatus* (Linnaeus 1758)) with a calculated Weber fraction of 0,35. In the same study and under the same experimental conditions two humans were tested for comparison purposes and the Weber fraction was calculated to be 0.11.

Brightness discrimination of the harbor seal (*Phoca Vitulina* (Linnaeus 1758)) was also investigated with the Weber fraction at 0.14 (comparable to that of humans). The Weber fraction implies the brightness discrimination ability of the fur seal is approximately half as good as that of the harbor seal. (Scholtyssek, Kelber and Dehnhardt 2007)

Geisbauer et al. (2004) found Weber fractions of 0.45 and 0.42 for two Haflinger horses (*Equus caballus* (Linnaeus 1758)).

Another study tried to determine thresholds of brightness discrimination with nocturnal kinkajou (*Potos flavus* (Schreber 1774)) but did not succeed because the 20-part series of greys was not a fine enough scale (Chausseil and Lohmer 1986).

Pretterer et al. (2004) found a Weber fraction of 0.22 for the German shepherd and 0.27 for the Belgium shepherd. An earlier investigation of Stone (1921) on the brightness discrimination ability in two fox terriers revealed a lower difference threshold. Only one standard intensity was tested, but the results he obtained were consistent for the two subjects with Weber fractions of 0.12 and 0.10, respectively.

Human discrimination threshold have been measured across a wide range of luminance, stimulus duration, stimulus size and other variables. Griebel and Schmid (1997) calculated Weber fractions of 0.11, Cornsweet and Pinker (1965), calculated 0.14. These results are also consistent with previous work in nonhuman primates. Crawford (1935) calculated a Weber fraction in the rhesus macaque (*Macaca mulatta* (Zimmermann 1780)) of about 0.1, and Huang et al. (2002) calculated between 0.11 and 0.18. Brooks (1966) found around 0.2 in the squirrel monkey (*Saimiri sciureus* (Linnaeus 1758)).

Budgerigars (*Melopsittacus undulatus* (Shaw 1805)) have a Weber fractions of 0.18, which is modest compared to other vertebrates (Lind et al. 2013).

The jumping spider *Menemerus bivittatus* (Dufour 1831) is one of the few invertebrates that has been tested in regards to the brightness discrimination abilities. This spiders hunts on either a dark surface (e.g. black painted poles) or on a light surface (e.g. walls of buildings) and on both these surfaces catch both light colored (e.g. small *Diptera*) and darkly colored prey (e.g. *Musca*), which raised the question about the capability of discriminating differences in contrast between stimulus and background. When the stimulus was darker than the background, there was a rapid increase in response as the stimulus gets darker. This rapid change in response with stimulus brightness did not occur when the stimulus was lighter than the background. Unfortunately, only behavioural responses were registered and there were no Weber fractions calculated but the results are consistent with a high contrast discrimination ability and show a dependence of the response on the overall stimulation conditions (Tiedemann 1993).

Zurek et al. (2010) tested another jumping spider *Servaea vestita* (Koch 1879) with moving dot stimuli with the resulting lowest perceived Weber contrast (the difference between the stimulus and background luminance, divided by the background luminance) that was

statistically significant of 0.01. Their results also indicated that female spiders are significantly more responsive than males.

Because of the variance in methodology, ambient light levels, statistical criterion for thresholds as well a small sample of animals it difficult to draw conclusions between diurnal, arrhythmic and nocturnal species as well as between the brightness discrimination and the ecology of the animal.

1.7. Aim

The aim of this study was twofold- it was to be able to compare the brightness discrimination ability with other species and to determine to what extent these spiders exploit the optics of their eyes especially in movement detection. We know a lot about species specific differences in color vision, acuity and other capabilities of the visual system, but we know very little about how species differ in brightness discrimination abilities. Three types of photoreceptors have been identified in *Cupiennius*, but as colour vision seems to be lacking (Orlando and Schmid 2010), we should turn to the brightness discrimination ability to indicate an alternative use of these three receptor types. In my experiments I made use of the fact that the perception of moving object in the secondary eyes enhances the eye muscle activity in the AM eyes. A significant change in frequency of the AM eye muscle should therefore indicated discrimination between stimulus and background.

2. MATERIALS AND METHODS

2.1. Experimental animals

For this study I used female adult spiders of the central American hunting spider- *Cupiennius salei* (Keyserling 1877). They came from the long term breeding stock at the Department of Neurobiology, University of Vienna and were bred in conditions resembling those of the spiders natural habitat with temperature at 22-28°C, relative humidity of 70-80% and under a 12/12 hour day/night cycle. Animals were kept individually in a glass jar and were fed flies once a week.

2.2. Single-channel telemetric device

I used a single-channel telemetric transmitter device to record the activity of the dorsal muscle of the principal eye (AM eye) of *Cupiennius salei*. This device was adapted for the spider by Dipl. Ing. R. Machan at the electronic laboratory at the Department of Neurobiology, Vienna, Austria (Fenk and Schmid 2010; Fenk and Schmid 2011; Neuhofer et al. 2009; Orlando and Schmid 2010) from the one that Kutsch et al. (1993) used with locusts.

A circuit diagram in figure 8 shows the devices 3 subunits: amplifier, modulator and sender. They are made of 8 resistors, 5 capacitors, 3 transistors and an inductor. The inductor, which is made of insulated copper wire, is connected with a capacitor into a LC-oscillator circuit. This is the key component of the device which generates a signal at a frequency of 130 MHz. This signal is then amplified 120 fold and frequency and amplitude modulated by the muscle potential of the AM eyes. This is what allows the eye-muscle potential to be transmitted over the carrier frequency.

A recording electrode made of isolated manganin-wire with a diameter of 30 µm (628.3 ohm/m; Isabellenhutte, Dillenburg, Germany) and a silver-wire reference electrode (250 µm) are attached to the transmitter. As a voltage source a battery (Maxell, 319 Silver 1.55V) delivered electricity for approximately 3 hours. The weight of the transmitter (battery included) was 650 mg which is a weight the spider should easily be able to bear.

The signal emitted by the device was received by a conventional wide band receiver (Conrad Voyager RY-630, Conrad Electronics, Hirschau, Germany), digitized by a an A/D converter (CED 1401, Cambridge, United-Kingdom), and finally sent to a computer for further analysis.

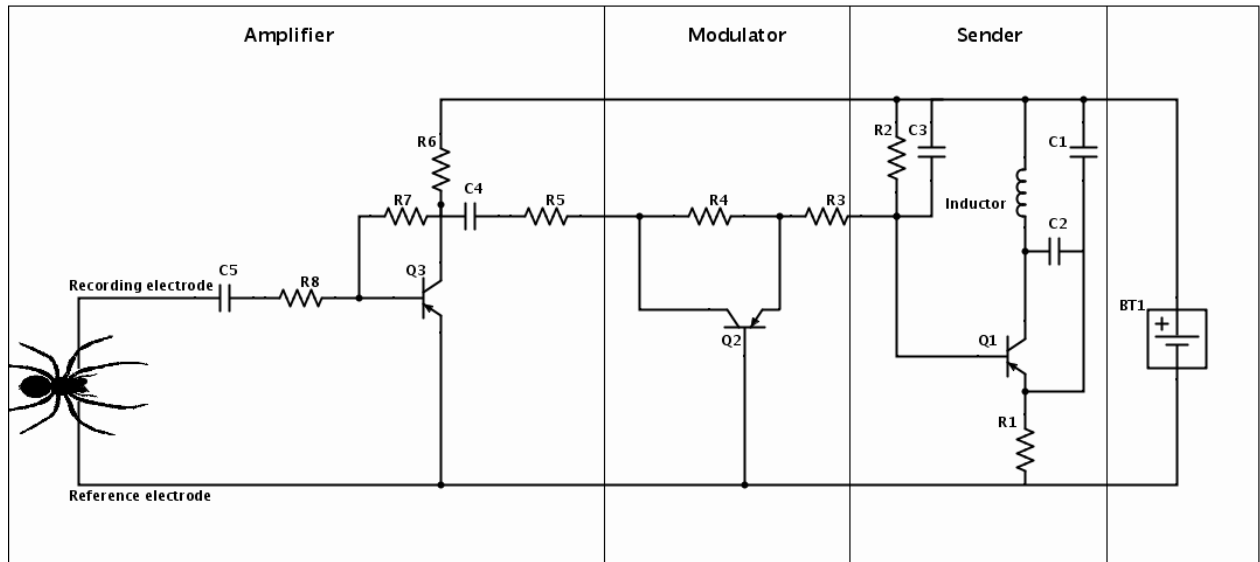

Figure 8. Circuit diagram of the telemetric single-channel transmitter. There are eight resistors (R), five capacitors (C), three transistors and one inductor. The signal is recorded then amplified. After amplitude modulation the signal is sent to a wide band receiver. A battery powers the device (picture after Orlando 2005, modified) .

2.3. Visual stimulation

In my experiments I made use of the fact that the principal eyes move involuntarily when objects are moving within the visual field of a secondary eye. The eye muscle activity of the principal eyes was recorded using single channel telemetric device described above, and activity changes were taken as an indicator for the perception of motion.

2.4. Stimuli

Fenk et al. (2010) showed for the first time, that visual stimuli alone can elicit attack behaviour in the laboratory after displaying the stimuli on a computer screen. The stimuli I used were created with Microsoft PowerPoint and were presented to the spider on a LCD-screen (Samsung SyncMaster 226BW, Samsung Electronics, Daegu, South Korea). The colors on a computer are generated with three color channels (red, blue, green). The “color” white is a mixture of these three primary colors. In my tests we used only the color green, with different brightness levels, for two reasons. First, by using only green (i.e. only one channel), the intensity depends minimally on the viewing direction. Second, the spectral composition of the green channel matches best with the spectral sensitivity of *Cupiennius salei*'s eyes (Barth et al. 1993), which is not the case for the blue (partial matching) or the red channel (no matching).

In this study, 51 shades of greens with different luminances were used. The “green value” corresponds to the value of the green component in the RGB (red, blue, green) color model. This model, using the three additive primary colors, codes all the colors in a computer (The values for the blue and the red components are here equal to 0). The luminance of single stimuli and backgrounds were measured with a luminance meter (Luminance Meter LS-100, Konica Minolta, Osaka, Japan) in the same conditions in which the experiments were performed (dark lab with only illumination by the screen) and from the same angle the screen would have been visible to the spider. The green shades and their corresponding luminance are shown in table 1. The lightest green is the green 255, the darkest one is the green 0. Several combinations of green (the green of the stimulus and that of the background) were used. 9 backgrounds were chosen ranging from lightest green (green 255) to black (green 0). For each background, 3 different brighter and 3 darker stimuli were used to determine the minimal perceived contrast (differing from the background by RGB integer values of green by 5, 10 and 15).

Table 1. Integer values in rgb system of different backgrounds and corresponding shades and luminances.

Green value	Shade	Luminance (cd/m ²)	Green value	Shade	Luminance (cd/m ²)
0		0.151	127		17.433
5		0.310	132		17.803
10		0.435	137		18.633
15		0.537	142		20.847
16		0.675	144		20.890
21		0.933	149		23.430
26		1.182	154		24.240
31		1.327	159		25.560
36		2.010	164		27.553
41		2.496	169		29.627
46		2.772	174		30.057
48		2.940	176		31.350
53		3.829	181		33.690
58		4.552	186		33.843
63		5.454	191		36.277
68		6.075	196		39.163
73		6.741	201		42.177
78		7.595	206		44.073
80		8.174	208		43.400
85		9.322	213		47.653
90		9.677	218		50.180
95		9.941	223		53.273
100		10.977	228		57.310
105		11.430	233		60.857
110		12.250	238		62.877

112		12.850	240		64.330
117		14.627	245		67.257
122		16.157	250		69.693
			255		71.027

Edge detection, the detection of lines in the image along which the luminance changes abruptly, has always been regarded as an important computation in image segmentation and processing (Marr and Hildreth 1980). In a twofold simultaneous choice experiment spiders strongly preferred a vertical bar to a sloping bar or a V shaped target (Schmid 1998). In Neuhofer's et al. (2009) study spiders responded well to moving black bars. Consequently I have chosen vertical stripes moving from left to right in front of the background as stimuli. The length of a bar was the same as that of the screen and of the 1/7th the width of the screen. The visual angle of the vertical bar at the distance of the spiders' initial position was in the order of 10 degrees.

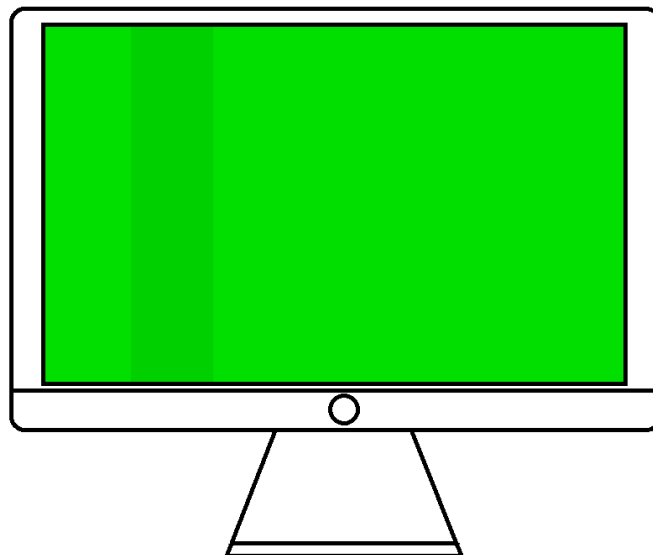

Figure 9. Stimulus green 208 on background green 223 as presented to the spider on a screen. The darker green stripe of the stimulus is moving from left to right on the screen. The duration of the presence of the stimulus on screen is 5 s. The time when the stimulus becomes visible to the spider is indicated by a signal which is registered on the recording. The signal would go off again when the stimulus disappeared from sight.

The stimulus lasted 5 s (“stimulus time”). It was preceded and followed by pauses (solely the background) lasting 15 s each (“interstimulus time”). 30 seconds were allowed at the beginning of the presentation for the spider to settle down and get used to the background. This stimulus-interstimulus sequence was repeated 6 times for each stimulus type before the next type was shown. These “sets” (a background and all the tested darker or brighter stimuli) were displayed to the spider in random order for each animal. Control was chosen to ensure that processor, screen activity and fan activity, was comparable to the activity during the presentation of the test stimuli.

A short signal would sound on the earphones to indicate the stripe has become visible on the screen in front of the spider, and another would go off when the stripe disappeared from the screen. These sound signals were registered on the computer which allowed me to examine the stimulus times during a recording.

The illumination level was measured to be in the order of 25lx at the spider's initial position pointing at the green screen (Fenk 2010, MT-51, Voltcraft).

2.5. Preparation of the experimental animal

In my experiments the animals had to be correctly positioned and should not move- therefore only females were used. They naturally move around much less than males (Schmitt et al. 1990). This is justifiable as there is no sex specific difference in the visual system.

In preparation for the experiments, the spiders were immobilized by cooling in a refrigerator at 4°C for about an hour. They could then be placed onto a turnable wooden spherical cap, connected to a magnetic stand by a ball bearing, where their legs, pedipalps and chelicerae were affixed to the holder with Parafilm[®] bands, the prosoma and opisthosoma being left free.

The small hairs on the left side of the prosoma and between the eyes were removed with round-ended tweezers in order to install the telemetric device. The telemetric unit was then attached to the spiders prosoma using putty. The reference electrode was inserted laterally into the opisthosoma. and the measuring electrode just below a PM eye, into the muscle of

the left or the right AM eye. To allow the implantation of the recording electrode I first perforated the cuticle with a electrolytically tapered tungsten-electrode. A picture of an affixed spider is shown in figure 10.

The signal from the transmitter was then received by the wide band receiver and was visible on the oscilloscope. When a sufficiently good signal-to-noise ratio (about 4:1), and a constant signal were achieved, the spiders could be positioned in the setup.

The spiders were always manipulated with care.

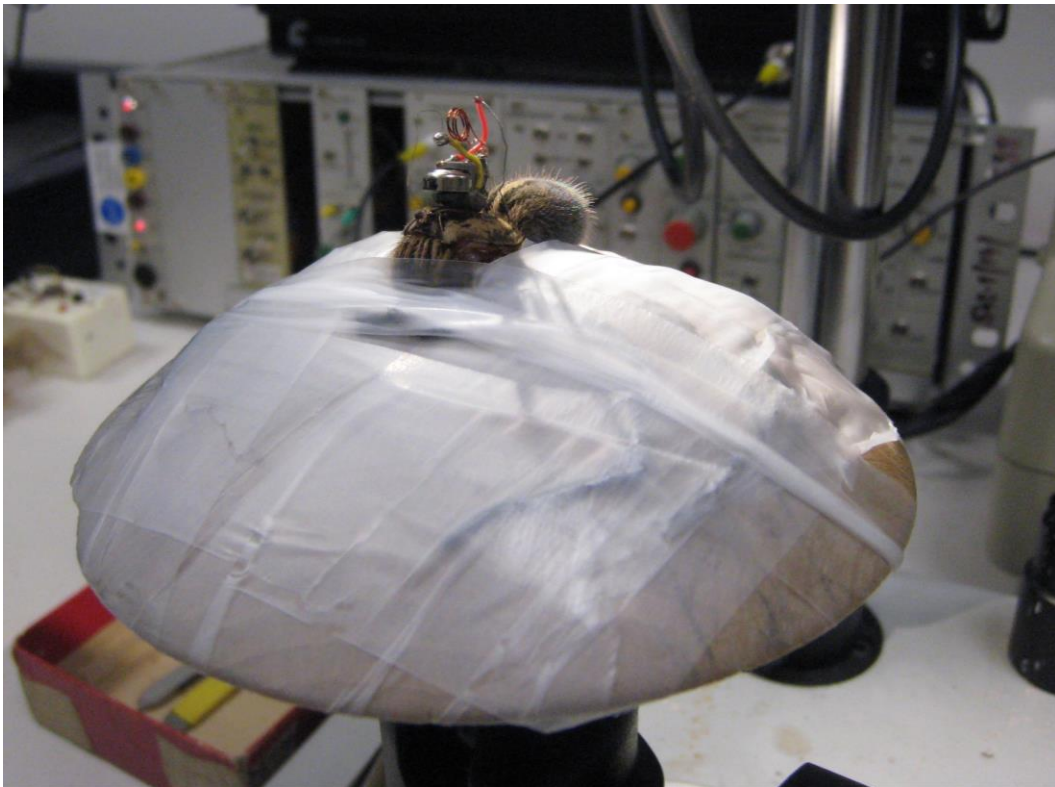

Figure 10. Side view of a *Cupiennius salei* experimental specimen with the telemetric transmitter in place. The animal was fixed onto a specimen holder with Parafilm[®], the holder was then rotated as it would be for viewing the presentation

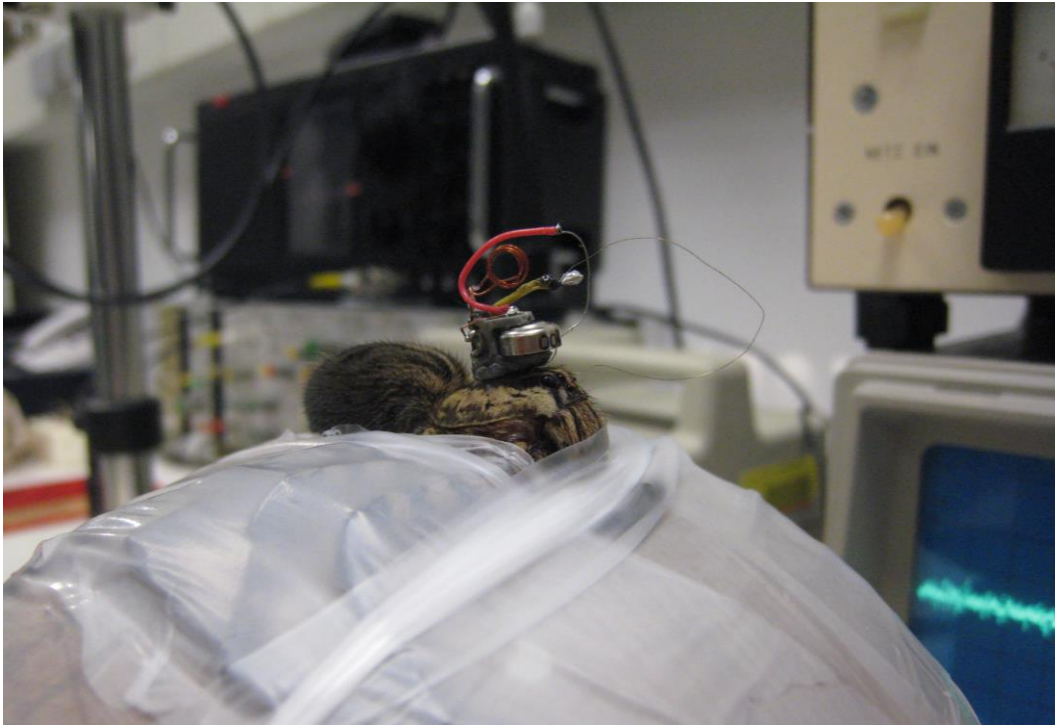

Figure 11. Close-up view of a *Cupiennius salei* with the telemetric transmitter in place. The reference electrode is implanted in the prosoma laterally (red wire), the recording electrode inserted into the muscle of the left AM eye (yellow wire).

2.6. Experimental setup

During stimulus display, the spider was positioned in front of the LCD-screen, with its body axis orthogonal to the screen at a distance of 20 cm, and rotated approximately 20 degrees in the horizontal plane, so that the width of the stimulus fit into the spiders visual field. Thus, the screen covered 70 degrees of the visual field of the spider, i.e. it covered the visual field of the two PM eyes (Land and Barth 1992). The experimental room was kept dark during the tests, except for the light from the LCD-screen presenting the stimuli to be discriminated. The monitor was switched on at least an hour before the start of the experiments.

The spider and the LCD-screen displaying the stimuli were placed within a Faraday cage positioned on an anti-vibration table to minimize the risk of spiders responding to mechanical

stimuli (TMC micro-g, Technical Manufacturing Inc., Peabody, USA). The spiders were dark adapted for about 10 minutes before the experiments.



Figure 12. Picture of the experimental setup. Visible here is the Faraday cage in which are the spider and the monitor on which the stimuli are presented. On top of the cage is the wide band receiver and on the right side of the Faraday cage the oscilloscope and an analog-digital converter.

Each spider was shown several different “sets” (background-stimulus combination) and both positive and negative control were included. The presentations were shown in a random order. When the experiment was finished, the animals were released.

2.7. Signal processing

The signal from the transmitter was received by a wide band receiver (CONRAD Voyager RY-630, Conrad Electronics, Hirschau, Germany) and relayed to a filter to reduce noise and to amplify the signal 10 times. To make the signal visible it was first conducted to an oscilloscope. To then analyse the analog signal it was A/D converted by an analog-digital converter (CED micro1401 mkII, Science Park, Cambridge, England).

Now it could be recorded with Spike 2 version 6.10 program (Cambridge Electronic Design, Cambridge, England) and stored for further analysis on the PC. The whole setup was earthed by an edge connector.

2.8. Data analysis

The AM eye dorsal muscle activity was recorded on a computer using the previously mentioned Spike 2 software. A screenshot is provided in figure 13. The increase of muscle activity due to visual stimulation was calculated by subtracting the mean spontaneous frequency measured in a time window of 5 s preceding stimulation from the mean frequency within the 5 s time window during visual stimulation.

Longer recording duration was not chosen because spiders can move their chelicerae and generate increases in frequency that were huge compared to the eye muscle potential. Recordings invalidated because of such artifacts or because of a poor signal to noise ratio were excluded from the analysis.

Differences between the spontaneous and the stimulus-induced eye muscle activity were calculated by a Spike2 script file. Differences between the mean muscle potential frequency for N spiders before and during stimulation were tested with the Wilcoxon signed-rank test using XLSTAT (Addinsoft, Paris, France).

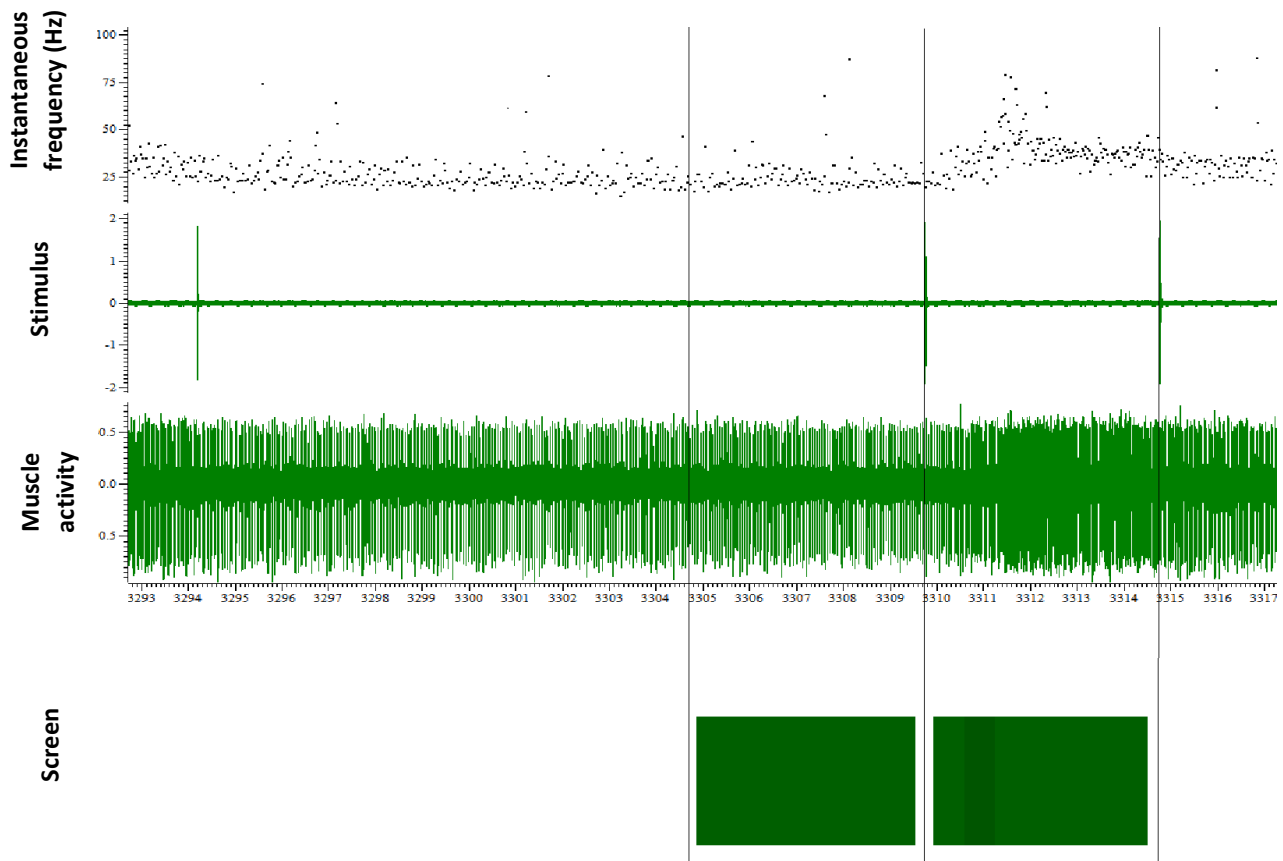

Figure 13. Screenshot of a recording. The vertical cursors indicate stimulus onset, also indicated by the spike at the middle trace. In this example, the stimulus displayed to *Cupiennius salei* is a dark moving stripe (green 85) on a brighter background (green 95). The AM eye muscle activity are the spikes in the bottom trace. From it, the instantaneous frequency can be calculated (black dots, upper trace) during the 5 s before the stimulus (between the two first cursors) and after the stimulus onset (between the two last cursors). Here, the frequency visibly increases after stimulus onset, which indicates that the spider perceives the contrast through its secondary eyes and reacts with its principal eyes.

3. RESULTS

3.1. Eye muscle potentials

The position of reference and recording electrode would vary slightly from measurement to measurement, which means there are a few distinct kinds of signals with different numbers of phases and duration. Dielectric characteristics of muscle and connective tissue can also be responsible for variations in the signals. Figure 14. shows an example of a tetra-phasic muscle potential in the duration of 1.7 ms. Noise of the transmitter is bordered by horizontal cursors.

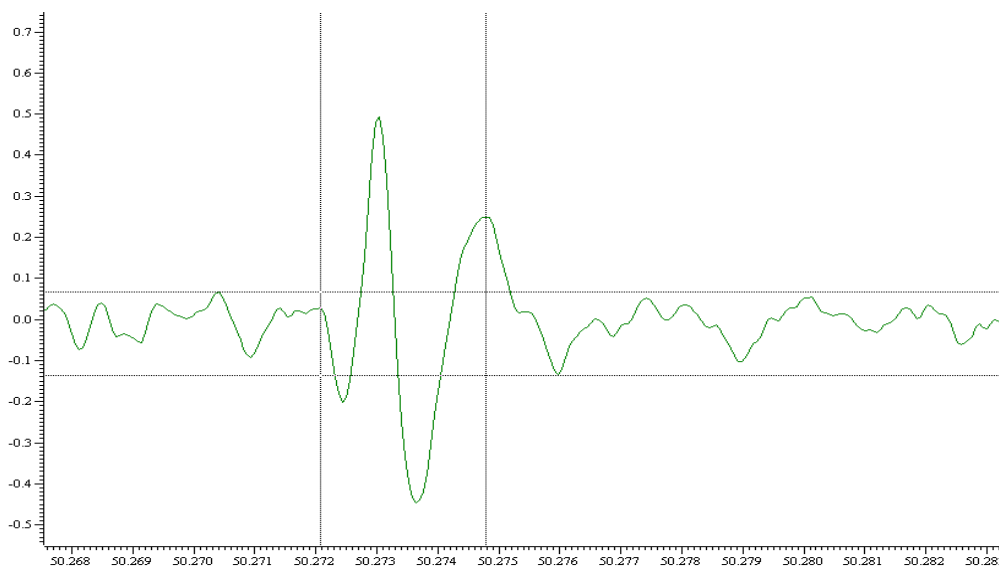

Figure 14. Single tetra-phasic eye muscle potential is bordered by vertical cursors. Noise is bordered by horizontal cursors and duration of the potential is 2.7 ms.

If the position of the recording electrode did not change during one recording session, the type of the signal remains the same. While different types of signals were used for the analysis, their form was not the determining factor, but their frequency.

3.2. Establishing the perception of moving stimuli

The assumption is that the secondary eyes of *Cupiennius salei* are the only ones that perceive moving stimuli because they are involved in detection of targets rather than their discrimination. Therefore, a perceivable contrast displayed to spiders' secondary eyes should elicit an increase in the principal eye muscle's activity. A significant change in frequency of the principal (AM) eye muscle should therefore indicate discrimination between stimulus and background. The frequency of the principal eye muscle was measured using the telemetric device described earlier.

I used a positive control between background and stimulus to test this hypothesis and to see whether the spiders can perceive the brightness difference in the experimental setup. Positive control consisted of the darkest green moving stripe (green 0) on the lightest green background (green 255) (see table 1). The result was statistically significant with a frequency increase of 7.76 ± 0.60 Hz.

We also tested the spiders with a negative control (either green 127 stimulus on a green 127 background, or green 0 stimulus on a green 0 background) to ensure the spiders were reacting only to the differences in brightness. Here no statistically significant increase was recorded: 0.16 ± 0.59 Hz or 0.50 ± 0.47 Hz respectively.

During the search for the just noticeable difference threshold seen by *Cupiennius salei*, the previously mentioned controls was displayed regularly to the spiders. In total each control was shown 6 times to each spider. In the case of the positive control, the statistically significant increase confirmed that the tested spiders could see luminance difference and that the telemetric device indeed recorded the principal eye muscles' activity.

3.3. The just noticeable brightness difference

In the experiments, the spiders were confronted with different combinations of green backgrounds and different shades of green stimuli. The results are given in full in table 2.

The just noticeable brightness difference perceived by *Cupiennius salei* depends on the the background, and whether the stimulus is brighter or darker than the background. We determined it by assessing the significance (Wilcoxon signed-rank test) of the increase in the principal eye dorsal muscle activity. Figure 15. presents the minimal Weber contrast perceived by *Cupiennius salei* as a function of the luminance of the background. Both curves show a characteristic shape with clearly discriminable slopes. Above a background luminance of 9 cd/m^2 (corresponding to green 95, see table 1.) the necessary Weber contrast that elicits a behavioral response is constant: around 0.17 for brighter stimuli and around 0.08 for darker stimuli. Below 9 cd/m^2 down to the minimal brightness level (close to 0 cd/m^2), another slope is observed. When the background becomes darker, the Weber contrast perceived by *Cupiennius salei* is higher. Thus, the highest value of Weber contrast is reached with brighter stimuli on the darkest background (contrast $C_w = 1.88$)

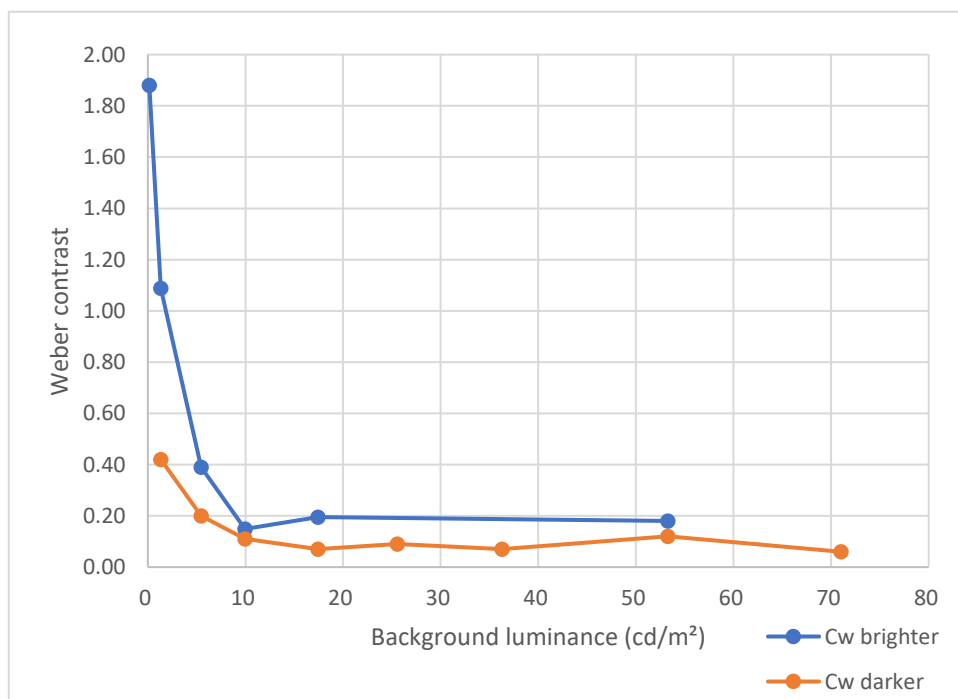

Figure 15. Weber contrasts (C_w) perceived by *Cupiennius salei*, as a function of the luminance of the background. After a certain luminance of the background ($\approx 9 \text{ cd/m}^2$), the brightness discrimination ability is constant for the spider, either with darker or brighter stimuli.

3.4. Increases in mean frequency for a single background

For a specific “set” the number of spiders tested ranged from 10-25 spiders. Each animal was shown a specific background-stimulus combination 6 times. All recordings were analysed and then combined for interpretation.

Figure 16. shows the frequency modulation (mean values with standard deviation) of all 7 stimuli displayed to the spider on background green 127. When stimuli are not discriminated, a frequency modulation of around 0 should be shown. If there is an increase in frequency, we presume discrimination of the stimulus from the background and confirm its statistical significance (p -value is < 0.05).

An increase in frequency for all the darker stimuli is found (especially stimulus 112 which shows a very high increase) as well as for stimulus 142.

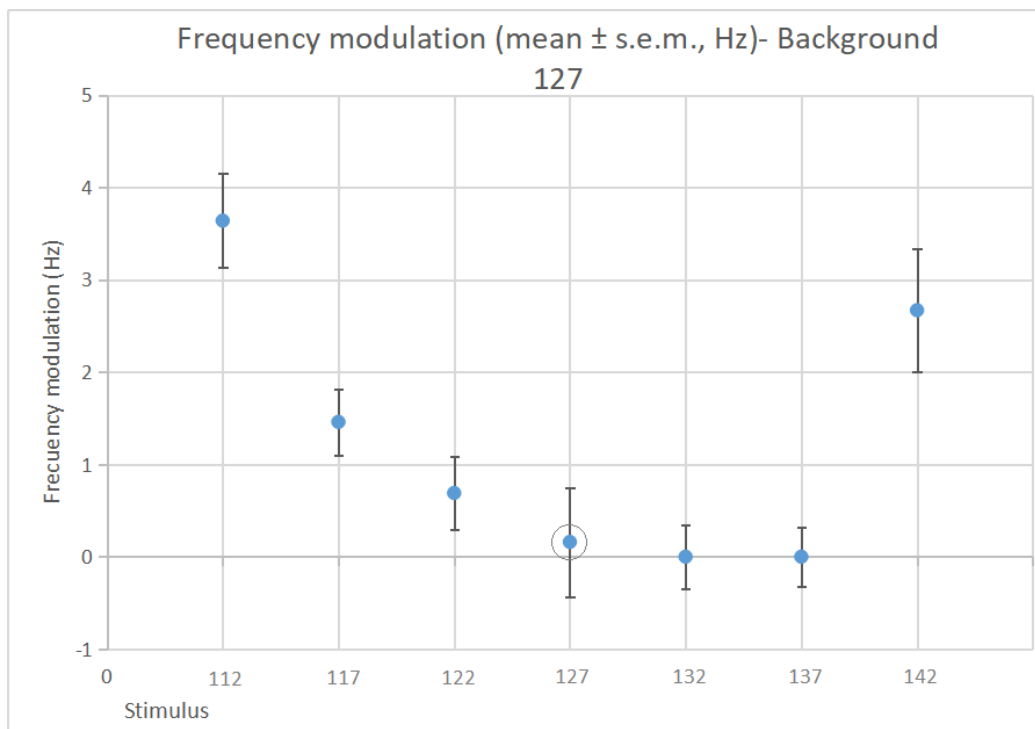

Figure 16. Mean values with standard deviations of the frequency modulation of the 7 stimuli presented to the spiders in front of background 127. An increase of frequency indicates discrimination between stimulus and background. Stimulus 127 (encircled) has the same luminance as the background.

Throughout the experiment the minimal perceived Weber contrasts are lower with darker stimuli than with brighter stimuli for the same backgrounds. Thus, the brightness discrimination ability is better with darker stimuli than with brighter stimuli. The spider's response rate was also better for darker than for brighter stimuli. These differences are statistically significant. However, these differences may be even more pronounced, because the just noticeable brightness threshold may be lower. We determined the "just" noticeable threshold in a relative manner by using different background/stimuli combinations. Applying even more combinations enables a more precise determining of the minimal contrasts detected by *Cupiennius salei*.

Also, when the background is darker than the stimulus, brightness discrimination may not be as well predicted by the luminance contrast statistics. A subject observing the display in a dark room will be affected mostly by light from the background, but if the stimuli are very bright, there may still be light scattered within the eye that produces more adaptation than indicated by the background luminance alone. The test subjects adaptive state may be affected by this, making the statistics less accurate predictors of actual perception and discrimination of stimuli (Whittle 1994).

3.5. Calculation of Weber fractions

I calculated the Weber fraction (k) to compare with other species. Because of the difference between the brightness discrimination ability with darker or brighter stimuli, two different fractions should be distinguished.

We calculated $k_{\text{darker}} = 0.15$ from the results with darker stimuli and $k_{\text{brighter}} = 0.65$ for brighter stimuli. The dependence between the noticeable difference threshold (ΔL , cd/m^2) and the background luminance (L , cd/m^2) was checked graphically (data not shown). The data falls approximately on a straight line indicating that the difference threshold (ΔL) is proportional to the background luminance (L). This agrees with Weber's law.

Table 2. Increase in the muscle's frequency for different stimulus background combinations. Weber contrasts were calculated using luminance values listed in table 1. The ones displayed here are for the just noticeable brightness difference threshold. The significance of an increase is assessed with the Wilcoxon signed-rank test (at least n = 42); significant results are printed in bold; * for p < 0.05, *** for p < 0.01; Backgrounds and stimuli values correspond to the value of the green channel in the RGB color model.

Background	Stimulus	Weber contrast	Increase in muscle frequency (mean ± s.e.m., Hz)	Sample size	
0	0	1.88	0.50 ± 0.47	69	
	5		0.37 ± 0.38	47	
	10		1.57 ± 0.48 ***	59	
	15		1.69 ± 0.47 ***	50	
31	16	0.42	4.07 ± 0.68 ***	50	
	21		2.49 ± 0.60 ***	47	
	26		1.24 ± 0.60	55	
	36		1.40 ± 0.84	56	
	41		-0.34 ± 0.80	54	
	46		1.09	0.82 ± 0.52 ***	48
63	48	0.2	3.13 ± 0.63 ***	48	
	53		3.70 ± 0.48 ***	68	
	58		0.99 ± 0.55 ***	58	
	68		0.68 ± 0.42	47	
	73		0.38 ± 0.45	45	
	78		0.39	1.57 ± 0.72 ***	60
95	80	0.11	2.65 ± 0.59 ***	61	
	85		4.65 ± 0.73 ***	52	
	90		1.33 ± 0.41 ***	46	
	100		0.51 ± 0.36	46	
	105		0.15	1.18 ± 0.46 ***	63
	110		0.93 ± 0.33 ***	104	
127	112		3.64 ± 0.51 ***	74	

		117			1.46 ± 0.36 ***	64
		122		0.07	0.69 ± 0.39***	65
		127			0.16 ± 0.59	58
		132			-0.12 ± 0.35	84
		137			-0.36 ± 0.32	59
		142		0.20	2.67 ± 0.67 ***	63
	159	144			1.28 ± 0.53 ***	49
		149		0.09	1.73 ± 0.50 ***	51
		154			0.47 ± 0.40	49
		164			0.18 ± 0.40	66
		169			-0.49 ± 0.31	48
		174			1.03 ± 0.75	57
	191	176			0.72 ± 0.51	48
		181			4.17 ± 0.70 ***	50
		186		0.07	0.97 ± 0.42*	47
		196			0.82 ± 0.79	57
		201			0.05 ± 0.35	50
		206			0.61 ± 0.45	52
	223	208			4.32 ± 0.56 ***	63
		213		0.12	4.55 ± 0.86 ***	66
		218			1.03 ± 0.50	46
		228			0.04 ± 0.48	59
		233			0.34 ± 0.68	54
		238		0.18	2.16 ± 0.78*	42
	255	240			3.89 ± 0.79 ***	54
		245		0.06	2.62 ± 0.64 ***	57
		250			1.52 ± 0.52	56
		255			-0.48 ± 0.35	48
	positive control	0			7.76 ± 0.60 ***	127

4. DISCUSSION

4.1. Brightness discrimination in the context of vision

The brightness discrimination ability of *Cupiennius salei* is dependant on the background luminance. Above a background luminance of about 9 cd/m², the minimal Weber contrast perceived by the spider is around 0.07 for stimuli darker than the background and 0.15 for brighter stimuli.

Below this luminance value, the Weber contrast increases as background luminance decreases. There seems to be a physiological threshold, below which the perception of differences in brightness decreases rapidly. As Land and Nilsson (2002) demonstrated for humans, an eye needs a certain number of photons to activate enough photoreceptor cells. Once enough photoreceptor cells are activated, the neural circuits of the brain can “calculate” a brightness difference and thus discriminate a stimulus.

At night, the active time of *Cupiennius salei*, luminance of the background of the spiders view is below 9 cd/m² (luminance is below approximately 1 cd/m²). In fact, under natural conditions, this spider mainly uses its mechanical senses (Barth 2002). It can use vision but to a lesser extent, as brightness discrimination is not totally impaired. As already mentioned, motion detection is colour blind and so depends on contrast discrimination (Orlando and Schmid 2010). Fenk et al. (2010) showed that visual cues alone can elicit attack behavior in *Cupiennius*. Lindner (2013) has shown that *Cupiennius salei* exhibits attack behavior more often towards a moving dot with a contrast of 1 (58% of positive reactions to the test), then with a contrast of 0.7 (13% positive reactions).

The brightness discrimination ability of *Cupiennius salei* proved to be significantly better with darker versus brighter stimuli compared to the background. The Weber fractions mirror this: values of Weber fractions with brighter stimuli are about 2 times times higher than those with darker stimuli.

This confirms a previous study (Fenk et al. 2010) that indicated that the spider “responded” better with a dark stimulus on light background than vice-versa in the context of attack behavior. Tiedemann’s (1993) study on *Menemerus bivittatus* also showed dark stimuli on bright background to be more effective in eliciting a response. The prey of *Cupiennius salei* is

variable and can be either darker or brighter than the environment (Barth and Seyfarth 1979), but for attack behavior correlated to moving stimuli, darker stimuli seem to be more relevant for *Cupiennius salei*.

Fenk and Schmid (2011) suggested a comparison with the toad . The toad has a lifestyle similar to *Cupiennius salei*: it is nocturnal with a “sit and wait” strategy. Toads’ eyes remain immobile and are thought to adapt to the stationary surroundings so that only moving targets are perceived. This is similar to the secondary eyes of *Cupiennius salei*.

Although prey detection mechanisms are probably very different from those in vertebrates, it would make sense for a sit and wait predator to have detectors like “bug detectors” in frogs that respond to dark objects entering the field of vision and moving with it.

Seyfarth's 1980 study shows that under controlled conditions of 12h light and 12h of darkness, regardless if these correspond to actual day and night, the spiders become active shortly after the onset of darkness. This makes it easy to turn our daytime into nighttime for the spider so we can have active animals available for observation conveniently in the middle of the day. This could be important when studying reflexes. Seyfarth (1980) learned that certain leg-muscle reflexes can be triggered much more easily during this “dark phase” of the day in a darkened laboratory.

Taking also into account the massive cyclic buildup and breakdown of the rhabdomeres from night to day (Grusch et al. 1997) it would be worth examining the difference between day- and night-adapted eyes in regards to brightness discrimination ability.

Applying more stimulus-background combinations would also enable a more precise determining of the just noticeable brightness difference threshold detected by *Cupiennius salei*.

4.2. Comparison with jumping spiders

Our results correlate with the findings of Tiedemann (1993) who studied brightness discrimination in the jumping spider *Menemerus bivittatus* by presenting circular prey stimuli

with varying gray values in front of a white, gray, and black background. The response rate increased faster with increasing contrast when the stimulus is darker than the background than when it is brighter than the background.

In Zurek's et al. (2010) study of the jumping spider, *Servaea vestita*, the lowest perceived Weber contrast that was statistically significantly perceived was 0.01. For *Cupiennius salei*, that value with darker stimuli was 0.06. The performance of *Servaea vestita* is therefore 6 times better than that of *Cupiennius salei* which is not surprising for a mainly visually guided spider.

4.3. Comparison with vertebrates

Weber fractions of *Cupiennius salei* are low for a small arthropod: its k_{darker} value is the same as that of a human. We can therefore claim that *Cupiennius salei*'s brightness discrimination ability is quite good, no doubt thanks to relatively big lenses, three different types of photoreceptors and a wide spectral sensitivity range. This also makes sense with the role brightness discrimination plays in motion detection.

It would not be surprising if, in general, carnivores had lower brightness discrimination thresholds (like those of *Cupiennius* or the harbor seal) than herbivores (like manatee and horse). Contrast is known to be an important parameter for perception of movement and movement direction (Buser and Imbert 1992), both very important when hunting. Low brightness discrimination thresholds would therefore facilitate the detection of movements and the movement direction of the prey whereas those factors might be less important for herbivore species.

The relatively high brightness discrimination threshold found for the dog by Pretterer et al. (2004) seems to argue against this hypothesis, but the results could be a consequence of the experimental method (because of the large distance between the stimuli the dogs were choosing from, choice could have been impeded and discrimination ability underestimated). Thus, the brightness discrimination ability tested by Pretterer et al. may have been underestimated while the lower values obtained by Stone (1921) are more realistic (Scholtyssek et al. 2008).

If so, this argues against Geisbauer's (et al. 2004) hypothesis that arrhythmic species are expected to have a higher brightness discrimination threshold than diurnal species such as humans. Fur seals, manatees, dogs and horses are all arrhythmic species i.e. active during the day as well during the night.

Currently, it is difficult to draw unequivocal conclusions about the correlation between brightness discrimination ability, life cycles and circadian rhythms, diet or optical properties of the animal's environment. For this further species need to be tested.

4. CONCLUSIONS

The aim of this study was to compare the brightness discrimination ability of *Cupiennius salei* with other species and to determine to what extent these spiders exploit the optics of their eyes especially in movement detection. After the experiments I concluded that:

- The spiders show an increase in eye muscle activity in their principal eyes when moving stimuli are detected in the secondary eyes.
- The brightness discrimination ability is significantly better with darker stimuli than with brighter stimuli.
- Two distinct Weber fractions were calculated. $k_{\text{darker}} = 0.15$ from the results with darker stimuli on a brighter background and $k_{\text{brighter}} = 0.64$ for the results with brighter stimuli on a dark background.
- Therefore, the brightness discrimination ability for darker stimuli of *Cupiennius salei* is comparable to that of humans.
- Above a luminance of 9 cd/m² of the background, the necessary Weber contrast that elicits a behavioural response is constant: between around 0.15 for brighter stimuli and around 0.8 for darker stimuli.

7. REFERENCES

Albert J. T., Friedrich O. C., Dechant H. E. and Barth F. G. (2001). Arthropod touch reception: spider hair sensilla as rapid touch detectors. *J. Comp. Physiol. A* 184, 303-312.

Barth F. G. (2002). *A Spider's World: Senses and behavior*. Springer, Berlin.

Barth F. G., Cordes D. (1998). *Cupiennius remedies* new species (Araneae, Ctenidae), and a key for the genus. *J. Arachnol.* 26, 133-141.

Barth F. G. and Seyfarth E.-A. (1979). *Cupiennius salei* Keys (Araneae) in the highlands of central Guatemala. *J. Arachnol.* 7, 255-263.

Barth F. G., Bleckmann H., Bohnenberger J., Seyfarth E.-A. (1988). Spiders of the genus *Cupiennius* Simon 1891 (Araneae, Ctenidae): II. On the vibratory environment of a wandering spider. *Oecologia.* 77(2), 194–201.

Barth F. G., Humphrey J. A. C., Wastl U., Halbritter J., Brittinger W. (1995). Dynamics of arthropod filiform hairs. III. Flow patterns related to air movement detection in a spider (*Cupiennius salei* Keys.). *Philos. Trans. R. Soc. Lond. B. Biol. Sci.* 347-412 (1322),397.

Barth F. G., Nakagawa T. and Eguchi E. (1993). Vision in the ctenid spider *Cupiennius salei*: spectral range and absolute sensitivity. *J. Exp. Biol.* 181, 63-80.

Blest A. D. (1978). The rapid synthesis and destruction of photoreceptor membrane by a dinopid spider: a daily cycle. *Proc. R. Soc. London, Ser. B* 200, 463-483.

Blest, A. D. and Land, M. F. (1977). The physiological optics of *Dinopis subrufus* L. Koch: a fish-lens in a spider. *Proc. R. Soc. Lond. B. Biol. Sci.* 196, 197-222.

Blest A. D. and Maples J. (1979). Exocytotic shedding and glial uptake of photoreceptor membrane by a salticid spider. *Proc. R. Soc. London, Ser. B* 204, 105-112.

Brooks B. A. (1966). Neurophysiological correlates of brightness discrimination in the lateral geniculate nucleus of the squirrel monkey. *Exp. Brain Res.* 2, 1-17.

Busch H., Dücker G. (1987). Das visuelle Leistungsvermögen der Seebären (*Arctocephalus pusillus* und *Arctocephalus australis*). *Zoologischer Anzeiger* 219 pp. 197-224.

Buser P., Imbert M. (1992). Movement Perception. In: P.A. Buser, Editor, *Vision*. The MIT Press, Massachusetts. pp.137-150

Cornsweet T. N. and Pinsker H. M. (1965). Luminance discrimination of brief flashes under various conditions of adaptation. *J. Physiol.* 176, 294-310.

Crawford M. P. (1935). Brightness discrimination in the Rhesus monkey. *Genet Psychol Monogr.* 17, 75-160.

Fenk L. M. and Schmid A. (2010). The orientation-dependant visual spatial cut-off frequency in a spider. *J. Exp. Biol.* 213, 3111-3117.

Fenk L. M., Heidlmayr K., Lindner P., Schmid A. (2010). Pupil Size in Spider Eyes Is Linked to Post-Ecdysal Lens Growth. *PLoS ONE* 5(12): e15838.doi:10.1371/journal.pone.0015838.

Fenk, L. M. (2011). On the performance of the visual system in the nocturnal hunting spider *Cupiennius salei*. Doctoral dissertation, University of Vienna.

Fenk L. M. and Schmid A. (2011). Flicker-induced eye movements and the behavioural temporal cut-off frequency in a nocturnal spider. *J. Exp. Biol.* 214, 3658-3663.

Fenk L. M., Hoinkes T. and Schmid A. (2010). Vision as a third sensory modality to elicit attack behavior in a nocturnal spider. *J. Comp. Physiol. A* 196, 957-961.

French A. S., Torkkeli P. H. and Seyfarth E.-A. (2002). From stress and strain to spikes: mechanotransduction in spider slit sensilla. *J. Comp. Physiol. A* 188, 739-752.

Foelix R. F., Choms A. (1992) *Biologie der Spinnen*. Georg Thieme, Stuttgart New York.

Geisbauer G., Griebel U., Schmid A. and Timney B. (2004). Brightness discrimination and neutral point testing in the horse. *Can. J. Zool.* 82, 660-670.

Griebel U. and Schmid A. (1997). Brightness discrimination ability in the west indian manatee (*Trichechus manatus*). *J. Exp. Biol.* 200, 1587-1592.

Grusch M., Barth F. G. and Eguchi E. (1997). Fine structural correlates of sensitivity in the eyes of the ctenid spider, *Cupiennius salei* Keys. *Tissue Cell* 29, 421-430.

Hergenröder R. and Barth F. G. (1983). The release of attack and escape behavior by vibratory stimuli in a wandering spider (*Cupiennius salei* Keys). *J. Comp. Physiol. A* 152, 347-359.

Huang X., MacEvoy S. P., Paradiso M. A. (2002). Perception of Brightness and Brightness Illusions in the Macaque Monkey. *J. Neurosci.* Nov 1, 22(21), 9618-9625 58.

Kaps, F. (1998). Anatomische und physiologische Untersuchungen zur Funktion der Retinabewegungen bei *Cupiennius salei*. Doctoral dissertation, University of Vienna.

Kaps F. and Schmid A. (1996). Mechanism and possible behavioural relevance of retinal movements in the ctenid spider *Cupiennius salei*. *J. Exp. Biol.* 199, 2451-2458.

Kelber A, Vorobyev M, Osorio D. (2003). Animal colour vision--behavioural tests and physiological concepts. *Biol Rev Camb Philos Soc.* 2003 Feb;78(1),81-118.

Kutsch W., Schwarz G., Fischer H. and Kautz H. (1993). Wireless transmission of muscle potentials during free flight of a locust. *J. Exp. Biol.* 185, 367-373.

Lachmuth U., Grasshoff M., Barth F. G. (1984). Taxonomische Revision der Gattung *Cupiennius* SIMON 1891 (Arachnida – Araneae – Ctenidae). *Senckenb. Biol.* 65 (3/6), 329-372.

Land M. F. (1971). Orientation by jumping spiders in the absence of visual feedback. *J. Exp. Biol.* 51, 471-493.

Land M. F. (1985). The morphology and optics of spider eyes. In: F.G. Barth, Editor, *Neurobiology of Arachnids*. Springer, Berlin. pp. 53–78.

Land M. F. (1981). Optics and vision in invertebrates. In: H. Autrum, Editor, *Handbook of sensory physiology*, Vol. VII/6B. Springer, Berlin. pp. 471-592.

Land, M. F. (1999). Motion and vision: why animals move their eyes. *J. Comp. Physiol. A* 185(4), 341–352.

Land M. F. and Barth F. G. (1992). The quality of vision in the ctenid spider *Cupiennius salei*. *J. Exp. Biol.* 164, 227-242.

Land M. F. and Nilsson D.-E. (2002). *Animal eyes*. Oxford University Press Inc., New York.

Lind O., Karlsson S., Kelber A. (2013). Brightness discrimination in budgerigars (*Melopsittacus undulatus*). *PLoS ONE* 8(1): e54650.doi:10.1371/journal.pone.0054650.

Lindner P. (2013). Visually elicited prey capture behavior in *Cupiennius salei*. Master thesis, University of Vienna.

Marr D., Hildreth E. (1980). Theory of edge detection. *Proc. R. Soc. Lond. B* 207, 187-217

Melchers, M. (1963). Zur Biologie und zum Verhalten von *Cupiennius salei* (Keyserling), einer amerikanischen Ctenide. *Zool. Jb. Syst.* 91, 1-90.

Melchers, M. (1967). Der Beutefang von *Cupiennius salei* Keyserling (Ctenidae). *Zoomorphology* 58, 321-346.

Menzel R. (1979). Spectral Sensitivity and Color Vision in Invertebrates. In: Autrum H. (eds) *Comparative Physiology and Evolution of Vision in Invertebrates*. Springer, Berlin. pp.503-580.

Nässel D. R. and Waterman T. H. (1979). Massive diurnally modulated photoreceptor membrane turnover in crab light and dark adaptation. *J. Comp. Physiol. A* 131, 205-216.

Neuhofer D., Machan R. and Schmid A. (2009). Visual perception of motion in a hunting spider. *J. Exp. Biol.* 212, 2819-2823.

Orlando E. (2005). Farbensehen bei einer Jagdspinne – Telemetrische Untersuchungen an *Cupiennius salei*. Diplomarbeit, Universität Wien.

Orlando E. and Schmid A. (2010). Colour blindness of the movement-detecting system of the spider *Cupiennius salei*. *J. Exp. Biol.* 214, 546-550.

Paulus H. F. (1979). Eye structure and the monophyly of the arthropoda. In: Gupta AP (ed) *Arthropod Phylogeny*. Van Nostrand Reinhold, New York pp. 299-383.

Pretterer G., Bubna-Littitz H., Windischbauer G., Gabler C., Griebel U. (2004) Brightness discrimination in the dog. *J. Vis.* 4, 241-249.

Schmid, A. (1997). A visually induced switch in mode of locomotion of a spider. *Z. Naturforsch.* 52C, 124-128.

Schmid A. (1998). Different functions of different eye types in the spider *Cupiennius salei*. *J. Exp. Biol.* 201, 221-225.

Schmitt A., Schuster M., Barth F. G. (1990). Daily locomotor activity patterns in the three species of *Cupiennius* (Aranea: Ctenidae). The males are the wandering spiders. *J. Arachnol.* 18 (3), 249-255.

Scholtyssek C., Kelber A., Dehnhardt G. (2008). Brightness discrimination in the harbor seal (*Phoca vitulina*). *Vision Res.* 48, 96-103.

Seyfarth E.-A. (1980). Daily patterns of locomotor activity in a wandering spider. *Physiol. Entomol.* 5, 199-206.

Stone C. (1921). Notes on light discrimination in the dog. *J. Comp. Physiol. Psychol.* 1, 413-431.

Strausfeld N. J., Barth F. G. (1993). Two visual systems in one brain II: Neuropils serving the secondary eyes of the spider *Cupiennius salei*. *J. Comp. Neurol.* 328, 43-62 60.

Strausfeld N. J., Weltzien P., Barth F. G. (1993). Two visual systems in one brain I: Neuropils serving the principal eyes of the spider *Cupiennius salei*. *J. Comp. Neurol.* 328, 63-75.

Tiedemann K. (1993). Visual brightness discrimination of the jumping spider *Menemerus bivittatus* (Araneae, Salticidae). *J. Arachnol.* 21, 1-5.

Trischler C. (2003). Telemetrische Registrierung der Augenmuskelaktivität von frei beweglichen *Cupiennius salei* (Araneae, Ctenidae). Diplomarbeit, Universität Wien.

Uetz G.W., Roberts J.A. (2002). Multisensory cues and multimodal communication in spiders: Insights from video/audio playback studies. *Brain. Behav. Evo.* 59, 222-230.

Walla P., Barth F. G. and Eguchi E. (1996). Spectral sensitivity of single photoreceptor cells in the eyes of the ctenid spider *Cupiennius salei* Keys. *Zool. Sci.* 13, 199-202.

Whittle, P. (1994). The psychophysics of contrast brightness. In: A. L. Gilchrist (Ed.), *Lightness, Brightness, and Transparency*. Hillsdale, NJ: Lawrence Erlbaum Associates. pp. 35-110.

Widmann, E. (1908). Über den feineren Bau der Augen einiger Spinnen. *Z. wiss. Zool.* 90, 259–308.

Zopf L. M., Schmid A., Fredman D. and Eriksson B. J. (2013). Spectral sensitivity of the ctenid spider *Cupiennius salei* Keys. *J. Exp. Biol.* 216, 4103-4108.

Zurek D. B., Taylor A. J., Evans C. S. and Nelson X. J. (2010). The role of the anterior lateral eyes in the vision-based behaviour of jumping spiders. *J. Exp. Biol.* 213, 2372-2378.