

An investigation of conceptual understanding of atomic spectra among university students

Ivanjek, Lana

Doctoral thesis / Disertacija

2012

Degree Grantor / Ustanova koja je dodijelila akademski / stručni stupanj: **University of Zagreb, Faculty of Science / Sveučilište u Zagrebu, Prirodoslovno-matematički fakultet**

Permanent link / Trajna poveznica: <https://um.nsk.hr/um:nbn:hr:217:780646>

Rights / Prava: [In copyright](#) / [Zaštićeno autorskim pravom.](#)

Download date / Datum preuzimanja: **2025-01-03**



Repository / Repozitorij:

[Repository of the Faculty of Science - University of Zagreb](#)



TABLE OF CONTENTS

INTRODUCTION	10
OVERVIEW	16
1. INTRODUCTION	17
2. PREVIOUS RESEARCH	20
3. CONTEXT FOR RESEARCH	23
3.1. INSTRUCTIONAL CONTEXT	24
3.1.1. <i>RELEVANT BACKGROUND OF STUDENTS</i>	25
3.2. RESEARCH METHODS	26
3.2.1. <i>INFORMAL OBSERVATIONS OF STUDENTS</i>	26
3.2.2. <i>INDIVIDUAL DEMONSTRATION INTERVIEWS</i>	27
3.2.3. <i>WRITTEN QUESTIONS</i>	28
4. RESEARCH ON STUDENT UNDERSTANDING OF THE ROLE OF THE EXPERIMENTAL SETUP	29
4.1. STUDENT INTERVIEWS ON BASIC SPECTROSCOPIC EXPERIMENTS	29
4.1.1. <i>CORRECT RESPONSES</i>	30
4.1.2. <i>OVERVIEW OF THE RESULTS</i>	31
4.2. WRITTEN QUESTIONS ON BASIC SPECTROSCOPIC EXPERIMENTS	32
4.3. RESULTS	34
4.4. SPECIFIC STUDENT DIFFICULTIES	35
4.4.1. <i>DIFFICULTIES ASSOCIATED WITH THE PRISM</i>	36
4.4.2. <i>DIFFICULTIES ASSOCIATED WITH A SINGLE SLIT OR DIFFRACTION GRATING</i>	37
5. RESEARCH ON STUDENT UNDERSTANDING OF ENERGY LEVELS AND TRANSITIONS	40
5.1. STUDENT INTERVIEWS	40
5.2. WRITTEN QUESTIONS ON ENERGY LEVELS AND TRANSITIONS	42
5.3. RESULTS	44
5.4. IDENTIFICATION OF SPECIFIC DIFFICULTIES	46
5.4.1. <i>ASSOCIATING EACH LINE IN A SPECTRUM WITH A SINGLE ENERGY LEVEL IN THE SOURCE</i>	46
5.4.2. <i>EQUATING THE ENERGIES OF THE SPECTRAL LINES AND THOSE OF THE ENERGY LEVELS IN THE SOURCE</i>	47
5.4.3. <i>FOCUSING ON THE NUMBER OF DISTINCT COLORS IN A LINE SPECTRUM, NOT THE TOTAL NUMBER OF LINES</i>	47
5.4.4. <i>NOT TREATING THE GROUND ENERGY LEVEL AS AN ENERGY LEVEL</i>	48
5.4.5. <i>TREATING ATOMIC TRANSITIONS AS ALWAYS INVOLVING THE GROUND ENERGY LEVEL</i>	49
5.4.6. <i>USING INCORRECT MODELS FOR EMISSION OF PHOTONS</i>	49

5.4.7. CONFUSING RELATED CONCEPTS	50
5.5. GENERAL FAILURE TO ASSOCIATE DISCRETE SPECTRA WITH TRANSITIONS BETWEEN ENERGY LEVELS	51
5.5.1. BELIEF THAT LINE SPECTRA CAN BE OBSERVED FOR ANY LIGHT SOURCE	51
5.5.2. FAILURE TO ASSOCIATE LINE SPECTRA WITH ATOMIC TRANSITIONS.....	52
6. ADDRESSING DIFFICULTIES WITH ENERGY LEVELS AND TRANSITIONS	53
6.1. CONTEXT FOR DEVELOPMENT OF CURRICULUM	53
6.2. SPECTRA TUTORIAL – ENERGY LEVELS AND TRANSITIONS	54
6.2.1. REVIEW OF STUDENT DIFFICULTIES.....	54
6.2.2. DESCRIPTION OF INSTRUCTIONAL STRATEGIES.....	55
6.3. ASSESSMENT OF INSTRUCTIONAL STRATEGIES	61
6.3.1. POST-TEST QUESTIONS AND THE RESULTS.....	61
6.2.2 DISCUSSION OF THE POST-TEST RESULTS.....	75
7. ADDRESSING STUDENT DIFFICULTIES WITH BASIC SPECTROSCOPIC EXPERIMENTS	77
7.1. SPECTRA TUTORIAL– OPTICAL SYSTEMS	77
7.2.1. REVIEW OF STUDENT DIFFICULTIES.....	77
7.2.2. DESCRIPTION OF INSTRUCTIONAL STRATEGIES.....	77
7.2. ASSESSMENT OF INSTRUCTIONAL STRATEGIES	84
8. CONCLUSION	90
SUPPLEMENTARY RESEARCH.....	92
OVERVIEW	93
1. INTRODUCTION	94
2. LIGHT SOURCES	95
2.1. SOURCES OF CONTINUOUS SPECTRA	95
2.1.1 INCANDESCENT LAMP	95
2.1.2. BLACK BODY	96
2.2. SOURCES OF LINE SPECTRA	99
2.2.1. FLAMES.....	99
2.2.2. SPECTRAL LAMPS.....	100
2.2.3. RADIATION	102
2.3. THERMODYNAMIC EQUILIBRIUM IN PLASMA	104
3. MAIN FEATURES OF PLASMA RADIATION	108
3.1. WIDTH AND SHAPE OF SPECTRAL LINES (THORNE, 1975).....	108
3.1.1. PRESSURE BROADENING	109
3.1.2. NATURAL BROADENING	118
3.2.1. DOPPLER BROADENING.....	121

3.2.2. COMBINATION OF GAUSSIAN AND LORENTZIAN LINE PROFILES.....	123
3.2. SELF-ABSORPTION.....	125
3.3. DETERMINATION OF PLASMA PARAMETERS	129
3.3.1. TRANSFORMATION OF THE OBSERVED RADIANCES INTO RADIAL DISTRIBUTION OF THE EMISSION OF PLASMA (Bockasten, 1961)	129
3.3.2. MEASUREMENT OF ATOMIC DENSITY.....	131
3.3.3. MEASUREMENT OF TEMPERATURE	134
3.3.4. CHARACTERIZATION IN NOT OPTICALLY THIN CONDITIONS (Lochte-Holtgreven, 1968)	136
4. CHARACTERISTICS OF HIGH PRESSURE INDIUM MERCURY METAL HALIDE DISCHARGE	138
4.1. HIGH INTENSITY METAL HALIDE DISCHARGES (OSRAM).....	138
4.2. IGNITING AND STARTING DISCHARGE LAMPS.....	140
4.3. HIGH-PRESSURE DISCHARGE WITH MERCURY AND INDIUM	142
5. DETERMINATION OF PARAMETERS OF MERCURY – INDIUM PLASMA ...	144
5.1. EXPERIMENTAL SETUP.....	144
5.2. CHARACTERISTICS OF MONOCHROMATOR	148
5.2.1. DETERMINATION OF THE WAVELENGTH CALIBRATION SCALE	148
5.2.2. INSTRUMENTAL FUNCTION OF THE MONOCHROMATOR.....	149
5.2.3. COMPARISON OF INTENSITIES OF HIGH AND LOW PRESSURE GAS DISCHARGES.....	152
5.2.4. EXPERIMENTAL CHECK IF LINE 577NM IS OPTICALLY THIN.....	157
5.3. RESULTS.....	160
5.3.1. TIME-AVERAGED OR AC MEASUREMENTS.....	161
MEASUREMENT OF GROUND STATE Hg DENSITY.....	163
TEMPERATURE OF DISCHARGE	165
5.3.1. TIME-RESOLVED MEASUREMENTS USING BOXCAR AVERAGER.....	169
6. DISCUSSION	172
BIBLIOGRAPHY	179
APPENDIX A: TUTORIAL, INTERACTIVE TUTORIAL LECTURE AND TUTORIAL HOMEWORK	182
A – 1 SPECTRA TUTORIAL – ORIGINAL VERSION.....	183
A – 2 SPECTRA – INTERACTIVE TUTORIAL LECTURE	187
A – 3 SPECTRA HOMEWORK – VERSION ONE.....	191
A – 3 SPECTRA HOMEWORK – VERSION TWO.....	193
A – 5 SPECTRA TUTORIAL – OPTICAL SYSTEMS.....	196
A – 6 SPECTRA TUTORIAL – CROATIAN VERSION: OPTICAL SYSTEMS	201
A – 7 SPECTRA TUTORIAL – CROATIAN VERSION: ENERGY LEVELS	205
A – 8 TUTORIAL HANDOUTS	209

STRUKTURIRANI SAŽETAK NA HRVATSKOM JEZIKU	211
PRVI DIO	213
UVOD.....	213
METODE ISTRAŽIVANJA I UZORAK ISPITANIKA.....	215
REZULTATI I SPECIFIČNE STUDENTSKE POTEŠKOĆE	220
<i>IDENTIFIKACIJA STUDENTSKIH POTEŠKOĆA VEZANIH UZ RAZUMIJEVANJE ULOGE EKSPERIMENTALNOG POSTAVA U FORMIRANJU SPEKTARA</i>	<i>222</i>
<i>IDENTIFIKACIJA STUDENTSKIH POTEŠKOĆA U RAZUMIJEVANJA VEZE IZMEĐU SPEKTRALNIH LINIJA I ENERGIJSKIH NIVOVA U ATOMU</i>	<i>225</i>
<i>OPĆENITE POTEŠKOĆE.....</i>	<i>228</i>
TUTORIJALI I NJIHOVA EVALUACIJA.....	230
ZAKLJUČAK.....	232
EKSPERIMENTALNI DIO.....	234
UVOD.....	234
TEORIJSKI UVOD	236
EKSPERIMENT	238
REZULTATI I DISKUSIJA.....	241
CURRICULUM VITAE	249

LIST OF FIGURES

Figure 0-1 Simple experiment demonstrating continuous spectrum	11
Figure 0-2 Spectrum of iron in 340 – 385 nm region recorded using spectrograph.....	12
Figure 0-3 Spectrum of iron in 340 – 385 nm region	13
Figure 0-4 An example of Dy-Ne line spectrum recorded with a grating spectrometer.....	15
Figure 3-1 Schema of the iterative cycle of research, curriculum development and instruction.....	23
Figure 4-1 The experimental setup problem: Question 1EX.....	33
Figure 4-2 The experimental setup problem: Question 2EX.....	33
Figure 5-1 Two different line spectra shown to students during the interview	40
Figure 5-2 Energy level diagram for Question 1EL.....	42
Figure 5-3 Lines and energy levels: Question 2EL.....	43
Figure 5-4 Lines and energy levels: Question 3EL.....	43
Figure 5-5 Diagram drawn by student for question 1EL.	49
Figure 5-6 Question 4EL - Additional question asked of students	50
Figure 6-1 Curriculum segment with use of student dialogue.....	55
Figure 6-2 Curriculum segment designed to help students to relate lines in spectrum with transition between energy levels in atom	56
Figure 6-3 Curriculum segment designed to help students to relate lines in spectrum with transition between energy levels in atom	57
Figure 6-4 Curriculum segment from tutorial homework.....	59
Figure 6-5 Curriculum segment from tutorial homework.....	60
Figure 6-6 Posttest question 1.....	63
Figure 6-7 Posttest question 2	66
Figure 6-8 Correct response on Posttest question 2, task (ii)	66
Figure 6-9 Posttest question 3	67
Figure 6-10 Correct answer on Posttest question 3, task (ii)	68
Figure 6-11 Posttest question 1	72
Figure 6-12 Posttest question 2	73
Figure 6-13 Posttest question 3	74
Figure 6-14 Posttest question 4	74
Figure 7-1 The first part of the tutorial – the student dialog.....	78
Figure 7-2 A problem from homework assignment	81
Figure 7-3 The homework assignment.....	82

Figure 7-4 Homework assignment, continued	83
Figure 7-5 The exam question	84

SUPPLEMENTARY RESEARCH

Figure 2-1 An example of incandescent lamp.	96
Figure 2-2 Spectral intensity distribution of Plank’s black-body radiation as function of wavelength for different temperatures.	97
Figure 2-3 Flame test for Sodium (from NaCl), Potassium (From KCl) and boric acid (H_3BO_3 contained in eve wash).....	99
Figure 2-4 Low- pressure mercury pencil lamp with Power Supply.....	101
Figure 2-5 The diagram of a high pressure lamp with its source of current.....	102
Figure 2-6 Two energy levels E_2 and E_1 populated by N_2 and N_1 atoms per cm^{-3} . a) spontaneous emission b) absorption c) induced transition.....	103
Figure 2-7 Electronic temperature and the temperature of the atoms and ions in plasma as a function of plasma pressure	106
Figure 3-1 Emission line profile and its full width at half maximum (FWHM). FWHM can be expressed in units of frequency $\Delta\nu$, units of wavelength $\Delta\lambda$, or in units of wavenumber Δk	109
Figure 3-2 Illustration of collisional line broadening and shift explained with the potential curves of the collision pair AB. Picture is taken from Demtröder, Laser Spectroscopy, 1998.	109
Figure 3-3 Geometry for calculating phase change	114
Figure 3-4 Damped oscillation with amplitude decaying as $e - \gamma 2t$ (a) and corresponding line profile	119
Figure 3-5 Illustration of uncertainty principle which relates the natural line width to the energy uncertainties of upper and lower level	120
Figure 3-6 Comparison of Lorentzian and Doppler line profiles of equal FWHM.....	123
Figure 3-7 Voigt profile as convolution of Lorentzian line shapes.....	124
Figure 3-8 Schemes for checking if the lines are optically thin. In a) the mirror was covered and only light from plasma was recorded and in b) the mirror behind plasma was used	126
Figure 3-9 A disk of plasma, axially symmetric with respect to the z axis, which is normal to the paper	129
Figure 3-10 Distortion of the intensity distribution due to reabsorption: a) Distribution of optical thickness within the line $\tau_0 \Delta\nu$, b) The function $Y(\tau_0 \nu, p)$, c) Resulting intensity distribution	137

Figure 4-1 An example of how a metal halide lamp works based on a double-ended lamp with a quartz arc tube.	138
Figure 4-2 Chemistry of the HID.....	139
Figure 4-3 Course of light parameters during start-up	141
Figure 4-4 An example of HQI-T 400 BLUE lamp.....	142
Figure 4-5 Spectrum of HgIn discharge	143
Figure 5-1 Experimental setup for time averaged measurements	145
Figure 5-2 Experimental setup for time resolved measurements:	146
Figure 5-3 Line triggering for time resolved measurements. The upper part displays the AC discharge current, the middle part – the corresponding time dependence of the photomultiplier signal, and the lower part – a general case of timing for data acquisition.	147
Figure 5-4 Calibration of the relative wavelength scale of SPM2 monochromator.....	148
Figure 5-5 The influence of monochromator on the width and shape of spectral lines	149
Figure 5-6 Instrumental function of monochromator. $(\Delta\lambda_{1/2})_G$ is the width of the instrumental function of the monochromator.	150
Figure 5-7 Dependence of instrumental function $(\Delta\lambda_{1/2})_G$ of SPM monochromator on the width of the monochromator slit.....	151
Figure 5-8 Dependence of instrumental function $(\Delta\lambda_{1/2})_G$ of ACTON monochromator on the width of the monochromator slit	152
Figure 5-9 Lines 577nm and 579 nm from high pressure discharge	153
Figure 5-10 Lines 577nm and 579 nm from low pressure discharge	154
Figure 5-11 Relative intensities of 577nm and 579 nm lines in high pressure discharge	155
Figure 5-12 Relative intensities of 577nm and 579 nm lines in low pressure discharge	155
Figure 5-13 The area $A = 2,27 \text{ cm}^2$ and radius $R = 20 \text{ cm}$	156
Figure 5-14 Line profiles of 577 nm line with and without duplicating mirror	157
Figure 5-15 Ratio of intensities of 577 nm line with and without the duplicating mirror	158
Figure 5-16 Experimental correction factor for 577 nm line	159
Figure 5-17 Example of the 577 nm and 579 nm lines on the uneven background..	160
Figure 5-18 Line 577 nm and corresponding Voigt profile (red). For this line, the instrumental (Gauss) width is 0.08 nm and corresponding Lorentz width equals $(0.2838 \pm 0.0007) \text{ nm}$	161
Figure 5-19 Line 1014 nm and corresponding Voigt profile. The instrumental (Gauss) width is 0.4nm and corresponding Lorentz profile is $(0.833 \pm 0.002) \text{ nm}$	162
Figure 5-20 FWHM of 577 nm line in dependence of chord offset.....	163
Figure 5-21 FWHM of 1014 nm line in dependence of chord offset	164

Figure 5-22 Measured relative intensities (points) of 577 nm spectral line as a function of chord offset. The distribution of points is very well fitted by Gauss profile with $\Delta x_G = (2.45 \pm 0.02)$ mm. Center of the discharge is in point $x_C = (3.739 \pm 0.007)$ mm 165

Figure 5-23 Radiances as a function of chord offset 166

Figure 5-24 Emission coefficients as a function of distance r from the center of the discharge 166

Figure 5-25 Dependence of the temperature of the discharge on the distance r from the center of the discharge 167

Figure 5-26 Normalized line intensities and line widths are shown for different phases of the current. 169

Figure 5-27 Relative intensities of the 1014 nm spectral line as a function of chord offset. Intensities were determined for different phases of current. Measurements were repeated for minimum and maximum of current as well as for three current phases in between I_{min} and I_{max} 170

Figure 5-28 FWHM of the 1014 nm spectral line as a function of chord offset. FWHMs were determined for different phases of current. Measurements were repeated for minimum and maximum of current as well as for three current phases in between I_{min} and I_{max} 171

Figure 6-1 Comparison of FWHMs of 577 nm line as a function of chord offset. 174

Figure 6-2 Comparison of FWHMs of 1014 nm line as a function of chord offset. 174

Figure 6-3 Experimental temperatures (points) compared with different temperature profiles. 175

Figure 6-4 Theoretical temperature profile compared with experimental temperatures from Zollweg 176

Figure 6-5 Temperature distribution for $r_0 = 4.7$ mm (empty circles) and $r_0 = 2.72$ mm (full circles) 177

Figure 6-6 Radial variations of the discharge temperature 178

LIST OF TABLES

Table 0-1 Wavelengths and intensities of spectral lines in the spectrum of iron in 340 – 385 nm region. Index m stands for measured values and index t for tabular values	14
Table 2-1 Excerpt from the list of common astronomy misconceptions. The left column in the table lists relevant topics and the right column the related specific student beliefs.	22
Table 4-1 Percentages of students who selected each option in Question 1EX. Last line shows percentages of students who realized that only replacing the source would result in a discrete spectrum.	34
Table 4-2 Results from question 2EX, in which students were asked about how a discrete spectral line pattern would change if the prism were removed from the optical setup.	35
Table 5-1 Percentages of correct answers for Questions 1EL, 2EL and 3EL.....	44
Table 5-2 Distribution of student answers on Question 2EL.....	45
Table 5-3 Distribution of student answers on Question 3EL.....	45
Table 6-1 Results from task (i) after tutorial instruction with comparison with the pretest.....	64
Table 6-2 Results from task (ii) after tutorial instruction.....	65
Table 6-3 Results from Posttest question 2, task (i).....	69
Table 6-4 Results from Posttest question 3, task (i).....	69
Table 6-5 Results from task (ii) from Posttest questions 2 and 3	70
Table 6-6 Summary of correct answers on task (i) given in various forms and to various groups of students together with pretest results	75
Table 6-7 Summary of correct answers on task (ii) given in various forms and to various groups of students.....	76
Table 7-1 Results of exam question after students completed tutorial or tutorial homework.....	85

SUPPLEMENTARY RESEARCH

Table 3-1 Calculated values for width ($\Delta\omega_{im}$) and shift ($\delta\omega_{im}$) of spectral lines for resonant, Stark and Van der Waal's interaction according to Lindholm-Foley impact theory	116
Table 3-2 Coefficients a_{jk} for transforming observed radiances $I(x)$ into emission coefficients $\epsilon(r)$. .	131
Table 5-1 Parameters of linear function that connects real and relative wavelengths	149

INTRODUCTION

Spectroscopy plays a key role in modern physics. Historical observations of discrete line spectra helped motivate the idea of quantization of energy levels in atoms and molecules and contributed to the development of quantum mechanics. The topic is taught from the introductory to the graduate level at universities and in high school physics and chemistry courses.

This dissertation reports on an in-depth investigation of student understanding of atomic spectra. The research was conducted at two universities: the University of Zagreb in Zagreb, Croatia and the University of Washington (UW) in Seattle, WA, U.S.A. The motivation was to ascertain the extent to which standard lecture instruction helps students understand the formation and interpretation of atomic spectra. More than 1000 students participated. At the University of Zagreb, these included second-year physics majors in introductory calculus-based physics and junior physics majors preparing to be teachers. Most of the participants were enrolled in the introductory calculus-based physics course at UW. A sub-group of these students were in a special honors section of this course.

In addition to identifying and analyzing specific difficulties encountered by the students, the dissertation describes preliminary efforts to develop, implement, and assess instructional strategies designed to address the conceptual and reasoning difficulties that we identified. The student difficulties are organized into two overlapping general categories: (A) Difficulties relating line spectra, energy levels, and transition, and (B) Difficulties elicited by the experimental set-up used to observe line spectra.

The investigation that is the major focus of the dissertation was enriched by supplementary research. This extension provided an example of the application of classical atomic spectroscopy methods through determination of the main parameters of high pressure metal halide discharges – temperature, atomic density, and pressure. The experiments described involved a high-pressure metal halide discharge and included an analysis of the visible and near infra-red part of the spectrum. The theoretical underpinnings and the experimental methods underlying the supplemental research were the basis for the questions developed for the investigation of student understanding of atomic spectra.

Electromagnetic spectra are typically introduced in an introductory physics course after students have studied physical optics. They must then make a transition from thinking of light as an electromagnetic wave to developing a conceptual model in which light consists of photons with discrete energies. In the classroom, instruction on spectroscopy often begins by showing students that white light incident on a prism or a diffraction grating in a spectroscope results in a continuous spectrum of colors, and that light from certain sources yields only discrete colors or wavelengths of light. The spectra are usually observed on a distant screen, and the experimental setup includes a light source, a slit (used as a mask) and a prism or optical grating (Fig 1.). Figure 1 shows an example of the experimental setup usually shown to students in introductory physics courses. The same setup was also shown to students during semi-structured interviews, and it also appeared in written questions that were a part of the research on student understanding of spectra.

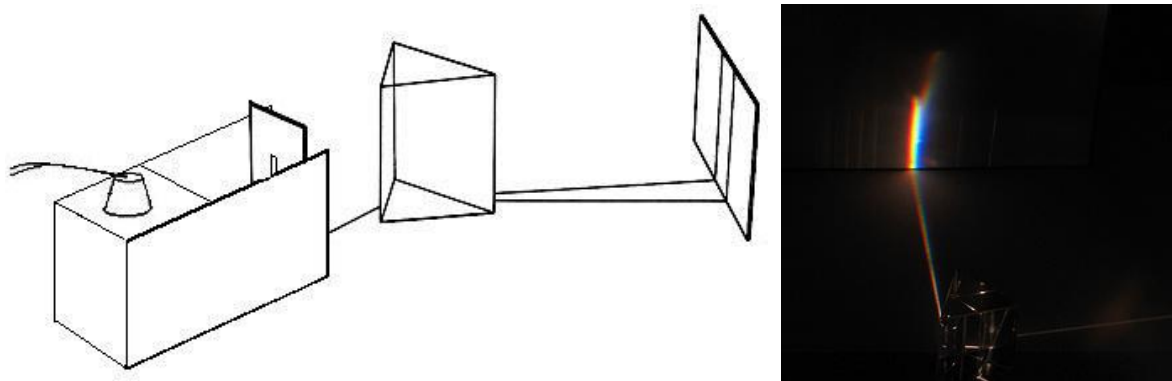

Figure 0-1 Simple experiment demonstrating continuous spectrum - taken from Practical Physics (<http://www.nuffieldfoundation.org/practical-physics>)¹

The spectrum in Figure 1 comes from the light of an incandescent lamp, and is continuous. In subsequent demonstrations, ionized gases are used to illustrate that for some sources of light only certain discrete wavelengths are seen, and that these are specific to the particular sources. The Balmer, Lyman, *etc.* series are introduced to illustrate patterns in the line spectra that are obtained for hydrogen. These observations help introduce the idea that the atoms in the sources have discrete, quantized energy levels, and that the emitted light results from transitions of electrons from one energy level to another. Each atom can be uniquely described by a set of energy levels that result in a characteristic emission spectrum.

¹ Disclaimer: The rule for citing the images that are not the work from the author can be found on: http://doktorski.unizg.hr/obad/upute_za_oblikovanje_doktorskog_rada

In presenting this sequence of ideas, instructors typically assume that students understand, or are familiar with, a number of underlying concepts. These include: (1) light can be treated as a wave and each color of light has a specified frequency and wavelength, and (2) light is refracted at different angles through a prism, depending on the wavelength, and interference of light takes place as a result of passing through a diffraction grating. To understand how discrete line spectra are related to atomic energy levels, students must also know that (3) light can be treated as consisting of photons, each with an energy that depends on the wavelength ($E_p = hc/\lambda$) and that (4) a discrete line spectrum is produced by photons that are emitted during electron transitions from one energy level to another ($\Delta E = E_2 - E_1$, where $\Delta E = E_p$).

Historically, the spectra were first recorded using spectrographs and photographic plates for detection and recording. An example of such a spectrum is given in Figure 2.



Figure 0-2 Spectrum of iron in 340 – 385 nm region recorded using spectrograph

Using microdensitometer this spectrum can further be examined and a distribution of relative line intensities obtained as in Figure 3.

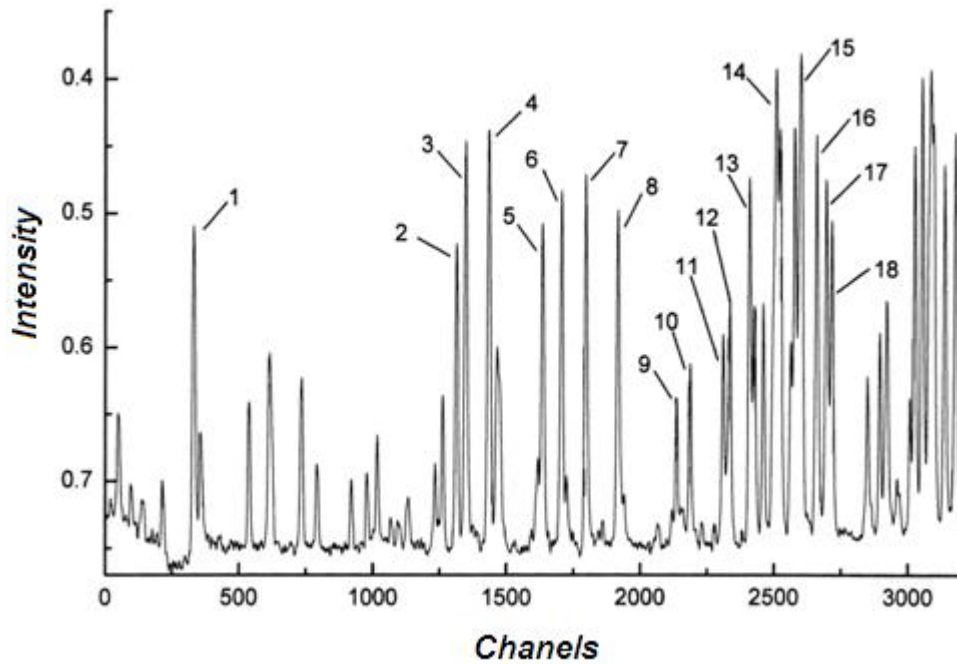

Figure 0-3 Spectrum of iron in 340 – 385 nm region

While only separated lines are shown in Figure 2, as well as on the screen during demonstration experiments in the class, in Figure 3 a distribution of atomic line intensities is shown. Knowing the characteristic wavelengths, lines can be linked with their associated wavelengths (Table 1). This spectrum also shows line profiles, in which each “line” is not a geometrical line, but has a structure, i.e. shape. Today, monochromators with optical gratings and photomultiplier (PMT) detection are usually used to analyze and record the spectrum. The result is the recorded intensity distribution (Fig. 4.).

Table 0-1 Wavelengths and intensities of spectral lines in the spectrum of iron in 340 – 385 nm region. Index *m* stands for measured values and index *t* for tabular values

line	channel	<i>N</i>	$\lambda_m / \text{\AA}$	$\lambda_t / \text{\AA}$	intensity _{<i>m</i>}	intensity _{<i>t</i>}
1	330.948	5199	3440.77	3440.76	526	714
2	1312.877	4594	3565.29	3565.38	464	429
3	1347.236	6677	3569.88	3570.10	675	429
4	1434.048	7481	3581.54	3581.20	756	857
5	1634.272	4699	3608.84	3608.86	475	571
6	1705.337	5351	3618.67	3618.77	541	571
7	1796.930	5889	3631.45	3631.54	595	500
8	1916.130	4642	3648.28	3647.84	469	571
9	2135.391	1392	3679.81	3679.91	141	429
10	2186.772	2180	3687.31	3687.46	220	429
11	2309.579	2564	3705.41	3705.57	259	714
12	2333.999	3096	3709.04	3709.25	313	571
13	2408.665	4849	3720.20	3719.94	490	1000
14	2508.347	7612	3735.24	3734.87	769	857
15	2599.469	9893	3748.99	3749.49	1000	1000
16	2658.921	6152	3758.29	3758.23	622	1000
17	2695.665	4771	3763.97	3763.79	482	714
18	2716.175	3913	3767.16	3767.19	396	714

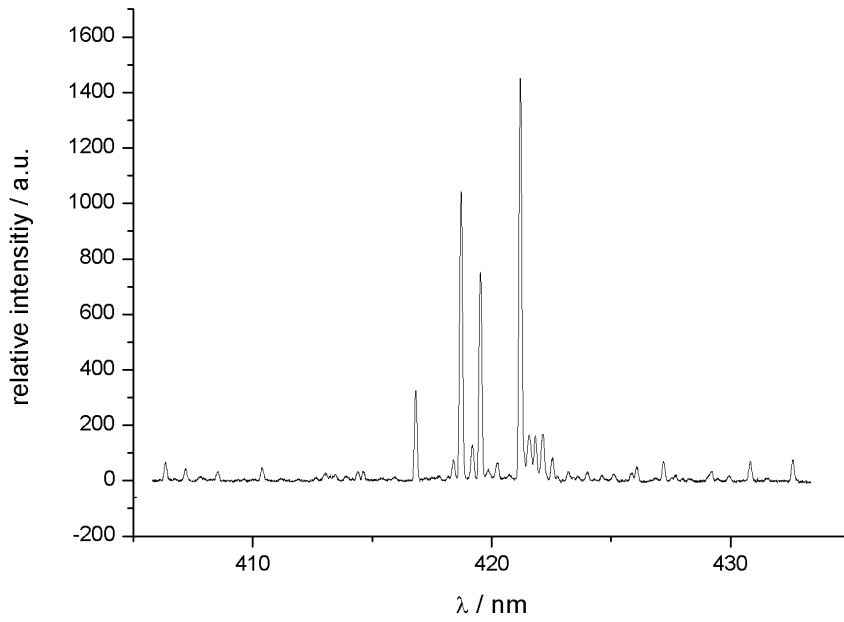

Figure 0-4 A portion of Dy-Ne line spectrum recorded with a grating spectrometer and detected by PMT

Independent of the way of recording the spectra, the atomic processes and transitions from which the spectra originate are the same. The dissertation provides insight into how well students understand the basic atomic processes. The supplementary research discusses the main theoretical ideas behind the formation of spectra and gives an example of the application of standard methods of spectral analysis.

OVERVIEW

Chapter One: Introduction

Chapter Two reviews the relevant previous research, especially prior studies of student understanding of light and quantum phenomena and also describes instructional materials developed previously.

Chapter Three describes the methods used, and the instructional setting in which the research and curriculum development took place.

Chapter Four describes the research on student understanding of the role of the various components of the experimental set-up that was used to observe spectral lines (*e.g.*, light source, entrance slit, prism, and diffraction grating). Student interviews are described and the results from pretest questions, together with descriptions of the most common student difficulties, are presented.

Chapter Five describes the research on student understanding of energy levels and transitions between them. Results from student interviews and written questions are presented, and the most common student answers are discussed.

Chapter Six describes a new tutorial and tutorial homework that have been developed to address student difficulties with energy levels and transitions. Written post-test questions and results are presented. The effectiveness of this instructional strategy is discussed.

Chapter Seven focuses on ways of addressing student difficulties with basic spectroscopic experiments. A new tutorial that was designed for this purpose is described and written posttest questions are presented. Posttest results and the effectiveness of the instructional approach are discussed.

Chapter Eight: Conclusion

1. INTRODUCTION

Physics education research has expanded rapidly over the last three decades. The most important results of physics education research systematically point to low efficacy of teaching by lecturing and suggest the need for the introduction of interactive teaching strategies that demand students' active intellectual engagement during teaching. Physics education research has produced an extensive knowledge base about student conceptual and reasoning difficulties regarding many physics topics. That knowledge has been very important for the development of interactive teaching strategies and instructional materials that are matched to student's abilities and needs.

The Physics Education Group (PEG) at the University of Washington (UW) has been conducting research on teaching and learning physics for many years. These investigations have primarily taken place in the context of introductory university physics courses. The careful documentation of student difficulties has proven invaluable in the design of instructional materials that have been shown to be effective in improving functional understanding of physics among undergraduate and graduate students and among pre-service and in-service teachers (McDermott, What we teach and what is learned: Closing the gap, 1991) In this dissertation, the term *functional understanding* connotes the ability to interpret a concept or observation properly, distinguish both from others that are related, and do the reasoning required to make the proper connections between the concepts and phenomena to which they apply.

In Croatia, physics education research is still a developing field of research which has, however, produced some important results in the last decade. Several studies have been conducted by the Physics Education Group at the University of Zagreb (Faculty of Science) in that period (Planinic, Ivanjek, & Susac, 2010) (Planinic M. , 2006) (Planinic, Boone, Krsnik, & Beilfuss, 2006), providing first results about teaching and learning physics in Croatia, and comparing those with international results.

Student understanding and interpretation of atomic spectra have not been widely investigated either in Croatia or in the U.S., or elsewhere in the world. It was recognized, both by the PEG at the University of Zagreb, Faculty of Science and the PEG at the University

of Washington, as an important topic that deserved attention and deeper investigation in both countries (Croatia and the USA).

Typically, spectroscopy is introduced to students by showing them that white light incident on a prism or diffraction grating in a spectroscope results in a continuous spectrum of colors. Subsequent observations using a prism or diffraction grating demonstrate that light from certain sources yields only discrete colors or wavelengths of light. The light enters through a narrow slit and the image of that slit is a line. Line position in the spectrum depends on the wavelength of the light. Line spectra imply that only certain discrete frequencies of radiation are emitted by the atom. These results help motivate the idea that electrons have only discrete, quantized energy levels in atoms and that the emitted light results from transitions of electrons from one energy level to another. Each atom can be uniquely described by a set of energy levels and by its characteristic emission or absorption line spectrum.

The sequence of ideas outlined above assumes that students understand, or are familiar with, a number of underlying concepts. These include the following: (1) light can be treated as a wave and each color of light has a specified frequency and wavelength and (2) light is refracted at different angles through a prism, depending on its wavelength, and/or that interference of light takes place as a result of passing through a transparent diffraction grating. To understand how discrete line spectra are related to atomic energy levels, students must also know that (3) light with a wavelength λ has an energy given by $E = hc/\lambda$ and (4) light observed in a discrete line spectrum results from a transition from one energy level to another.

A major goal of the research described in this dissertation is to probe the extent to which students understand the relationship between atomic spectra and energy levels. A particular focus is on the ability of students to recognize the conditions under which discrete spectra are and are not formed and to relate the wavelengths of light in discrete line spectra to the transitions of electrons between the energy levels in an atom.

Results from the investigation indicate that conceptual difficulties often prevent students from developing a functional understanding of spectra. In addition, the data suggest that most students are not able to match observations of spectra with the formalism taught in

standard lectures. These results have been used to develop instructional materials that help address some of the difficulties that have been found.

2. PREVIOUS RESEARCH

Although there is not much research that directly concerns student understanding of spectra, there have been a number of published PER studies that document student thinking about concepts that underlie spectroscopy, such as geometrical and physical optics concepts (Ambrose, Shaffer, Steinberg, & McDermott, 1999), (Wosilait, Heron, Shaffer, & McDermott, 1999), (Heron & McDermott, 1998), (Wosilait, Heron, Shaffer, & McDermott, 1998). Some related ideas, such as quantization of energy, have also been explored (Asikainen & Hirvonen, 2009). There have also been some studies in the context of introductory quantum mechanics (Vokos, Ambrose, Shaffer, & McDermott, 2000). These studies have been conducted at both the precollege and university levels. None of them, however, directly addressed student understanding of atomic spectra. There are very few studies that have been directly related to student thinking about atomic spectra, and these came partly from the physics education research (Lee, 2002) and partly from the astronomy education research communities (Bardar, 2006).

In their physics and astronomy courses, students are taught that light has both wave-like and particle-like behaviors. Experienced instructors recognize that students often have difficulty in determining when to apply each model (Vokos, Ambrose, Shaffer, & McDermott, 2000). A series of investigations at the University of Washington, for example, documented the tendency of university students to use concepts from physical optics to solve problems related to geometrical optics and vice versa. In some cases, students used a hybrid model to account for interference effects. The difficulties persisted despite instruction in both introductory and sophomore-level modern physics courses.

Single slit diffraction has been used to test students' ability to apply the formalism of light as a wave (Ambrose, Shaffer, Steinberg, & McDermott, 1999). In that study 510 students were asked whether the width of the slit should be greater than, less than, or equal to the wavelength of the incident light for diffraction to occur. Although 45% of the students answered correctly, indicating that the width of the slit should be greater than the wavelength of the incident light, only 10% of the students provided correct reasoning (Wosilait, Heron, Shaffer, & McDermott, 1999). Of the 40% who incorrectly believed that diffraction would occur if the slit width was less than the wavelength of the incident light,

several based their reasoning on whether or not the light would fit through the slit, claiming that light has to bend in order to fit through a narrow slit.

Another study probed the ability of elementary education majors to use a diffraction grating to observe spectra and also examined student ideas about the relationship between the energy and the wavelength of light (Lee, 2002). In his dissertation study of introductory college physics students' understanding of spectra, Lee collected information regarding students' conceptions of colored light. His findings were based on their observations of incandescent lamps with colored filters, their abilities to use diffraction gratings and spectrometers to observe spectra, and their ideas about the relationships between energy and light in spectra. An important finding was that many of these students were unable to identify the spectrum coming from the hydrogen lamp as a line spectrum. When asked to sketch their observations, students who had not studied spectroscopy often sketched bands that seemed to represent a continuous spectrum of light. Students who had studied the topic often drew both bands and lines. The investigation also identified a student tendency to relate the energy of light to the intensity, rather than to its color. Lee also found that many students incorrectly related the color mixing of light to the color mixing of paints. They often indicated that black is the presence of all colors in light rather than the absence of color.

Student understanding of spectral lines and of the nature of the electromagnetic spectrum was also tested with the Light and Spectroscopy Inventory (Bardar, 2006), a multiple-choice instrument developed to probe student understanding about the range of topics covered in introductory astronomy courses. The test includes questions that probe student ability to relate wavelength, frequency, energy, and speed of light, as well as questions about features of spectral lines and the underlying processes of emission and absorption of light. Analysis of the results suggests that many students struggle with both types of questions, both before and after standard instruction. Significant student difficulties were revealed by questions that asked students to identify the process in which an absorption line or emission line was formed. Only between 15% and 20% of students answered these questions correctly prior to instruction, and only about 25% of students answered correctly after standard lecture instruction. These results indicate that most of the students did not understand the process of light emission and absorption, even after

instruction. However, the difficulties associated with the ability of students to interrelate several properties of light appear to be more readily addressed. In courses that incorporated activities designed to engage students in their own learning, student performance on the associated questions tended to improve significantly (from about 29% on the pretest to 46% after standard instruction, and to between 66% and 73% after interactive engagement). However, the questions that probe student ability to relate spectral lines to absorption and emission of light showed much less improvement (from 19% on those items before instruction to 24% after standard instruction, and to 40% after interactive engagement).

By collecting student responses to different questions, Comins (Comins, 2001) compiled a list of over 1700 commonly held astronomy misconceptions, several of which are related to light and spectra. Some of them are listed in Table 2-1

Table 2-1 Excerpt from the list of common astronomy misconceptions. The left column in the table lists relevant topics and the right column the related specific student beliefs.

STELLAR TEMPERATURES	<ul style="list-style-type: none"> - The bigger the star is, the hotter it is - red stars are hottest (red = hot, blue =cold) - stars of equal temperature all have equal brightness
STELLAR SIZES	<ul style="list-style-type: none"> - the bigger the star is, the brighter it is
STELLAR SPECTRA	<ul style="list-style-type: none"> - stars emit only one color of light - stars only give off visible light - heat and light from stars are unrelated
STELLAR ENERGY	<ul style="list-style-type: none"> - stellar size, color and temperature are unrelated
PHOTONS	<ul style="list-style-type: none"> - longest wavelength photons carry the most energy - photons behave only like particles - photons travel on waves
SPEED	<ul style="list-style-type: none"> - different kinds of electromagnetic radiation travel with different speeds - radio waves travel at the speed of sound
GENERAL	<ul style="list-style-type: none"> - visible light is fundamentally different from other types of electromagnetic radiation - all spectra are continuous - the spectrum of light is the shape the light makes - all electromagnetic radiation is visible

3. CONTEXT FOR RESEARCH

The research that forms the basis of this dissertation was influenced by prior research in physics education, in particular by the tradition of the Physics Education Group at the University of Washington.

Since the early 1970's, the Physics Education Group at the University of Washington has been engaged in an iterative cycle of research, curriculum development and instruction with the goal of improving student learning in physics (Figure 3-1).

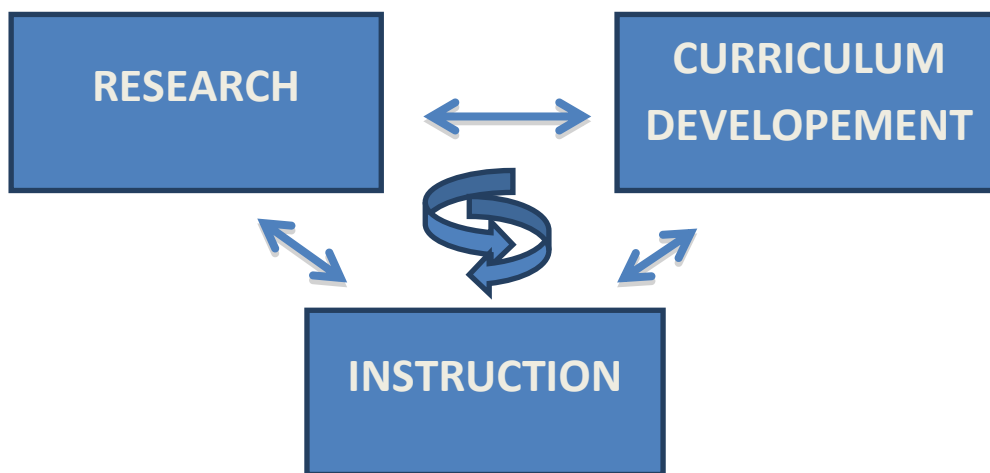

Figure 3-1 Schema of the iterative cycle of research, curriculum development and instruction

Various research methods have been developed and used (e.g., interviews, informal observations and written questions). In addition, the group has developed a number of instructional materials (McDermott, Shaffer, & Physics Education Group, 2002) which have proved to be effective (McDermott L. , 2001). Tutorials in Introductory Physics are a set of materials intended to supplement the lectures and textbook of a standard introductory physics course. The emphasis in the tutorials is on the development of important physical concepts and scientific reasoning skills, not on solving the standard quantitative problems found in traditional textbooks. Each tutorial consists of a pretest, the tutorial worksheet, tutorial homework and a posttest. The tutorial sequence usually begins with a pretest, which is usually on material already covered in a standard lecture. The pretest helps students

identify what they do and do not understand. The pretests also inform the instructors about the level of student understanding. The worksheets, which consist of carefully sequenced tasks and questions, guide the students in the necessary reasoning. Students work together in small groups constructing answers for themselves through discussion with one another and with tutorial instructors. Many tutorials can be characterized by the strategy that begins by *eliciting* conceptual and reasoning difficulties. The students are then guided through the process of *confronting* and *resolving* their difficulties. The role of the Teaching Assistants is to engage students in a semi Socratic dialogue in which they supplement the questions on the worksheets by asking additional questions, rather than by simply providing the answers. The purpose is to guide students through their own intellectual efforts to an understanding of the material. The tutorial homework reinforces and extends what is covered in the worksheets. The post-test questions examine student understanding of the concepts and reasoning skills developed in tutorials. The tutorials are primarily designed for small class settings but have proved to be adaptable to other instructional environments.

3.1. INSTRUCTIONAL CONTEXT

A large part of the research discussed in this dissertation has taken place in in the context of tutorial instruction in introductory physics courses at the University of Washington. Part of the research has taken place in introductory physics courses at the University of Zagreb. Some preliminary data were also collected from physics students in advanced physics courses in the Faculty of Science, University of Zagreb.

3.1.1. RELEVANT BACKGROUND OF STUDENTS

The data presented in this dissertation was obtained from a variety of students with a wide range of backgrounds in physics. Some were enrolled at the Faculty of Science, University of Zagreb, in Zagreb, Croatia. Most were students at the University of Washington (UW), Seattle, WA, USA.

STUDENT POPULATIONS AT THE UNIVERSITY OF WASHINGTON

During their first year, students at the University of Washington are expected to take three quarters of introductory calculus-based physics (Physics 121 covers mechanics; Physics 122 covers electromagnetism and oscillatory motion; and Physics 123 covers waves, optics, and modern physics) as well as three quarters of calculus. The introductory physics courses consist of three parts: lectures, laboratories and tutorials. The lectures and laboratories are typical of those found at other institutions. There are three hours of lectures per week and one hour of laboratory instruction per week. Tutorials have already been described earlier in this chapter. They take place once each week and are a required part of the course at the University of Washington. The prerequisites for Physics 121, 122 and 123 are one year of high school physics and the equivalent of calculus with analytic geometry. The data were obtained from students at the University of Washington who were all undergraduates enrolled in the introductory calculus-based physics sequence. They were in the third course in the sequence. All had completed the first two courses in the sequence on mechanics and electromagnetism. Most of the students ($N \sim 950$) were taking the standard introductory course. The others ($N = 85$) were enrolled in a special 'honors' version of the course.

STUDENT POPULATIONS AT THE UNIVERSITY OF ZAGREB

The students at the Faculty of Science, University of Zagreb, included two populations:

- (1) second year physics majors in introductory calculus-based physics course (Opća fizika 4) (CRO INTRO; N = 92);
- (2) junior physics majors, students in 6th semester of study (CRO JUNIORS; N = 62).

The second year students had completed calculus, General Physics 1 – 3 (mechanics, electromagnetism, waves and optics), and were enrolled in General Physics 4, covering thermal and modern physics. The General Physics course at the University of Zagreb consists of four hours of lectures per week and three hours of recitations per week. The recitations usually include the solving of standard problems although some of the instructors started recently replacing one hour of recitations by the tutorials and using cooperative group problem solving in recitations. All juniors had completed all general physics courses, basic labs, and the quantum mechanics course.

3.2. RESEARCH METHODS

Various research methods were used in the investigation described in this dissertation. These methods include informal observations of students, individual demonstration interviews, and written questions. The research methods and their significance for this investigation are described below.

3.2.1. INFORMAL OBSERVATIONS OF STUDENTS

Informal observations of students in the classroom have helped to guide this study, especially in the early stages. The observations of students in the labs gave the first insight into difficulties that they have with interpreting line spectra, and motivated the research of this dissertation.

3.2.2. INDIVIDUAL DEMONSTRATION INTERVIEWS

Semi-structured individual demonstration interviews were conducted with nine Croatian upper-level physics students who were intending to become physics teachers. They were in their fourth year of study at the University of Zagreb. They had each completed the introductory physics sequence in which modern physics had been taught. They also had taken an upper-division optics laboratory course (Praktikum iz eksperimentalne nastave fizike) and a course on quantum mechanics. The interviews, which lasted between 45 minutes and one hour, were recorded, transcribed, and analyzed.

The Interview questions were intended to probe student ability to apply a specific concept studied in the course. The students were asked to make predictions about what would happen if specific changes were made to a physical system. Generally, the system under consideration was shown to students during the interviews. The students had the opportunity to speak openly about what they saw, and how they understood the experimental setup. All the students were volunteers who had generally performed above the average in their coursework. Previous studies carried out by the Physics Education Group at University of Washington have shown that difficulties prevalent among interview volunteers are often widespread in the general student population (McDermott, Shaffer, & Somers, 1994).

At the beginning of each interview, the participants were told briefly about the purpose of the interview and its role in the study. Before and during the interviews, the students were encouraged to think out loud. It was made clear that the interviewer was interested in their reasoning and not only in the specific answers. If a student made an incorrect statement, he or she was not corrected by the interviewer. The students were told that they would have an opportunity to ask questions about the subject matter after the interview if they wished to do so.

3.2.3. WRITTEN QUESTIONS

Written questions were given to supplement the results from the interviews. Sometimes these problems have been given as a required component of the course, but they were not always used for student assessment. If given as a part of a regular course examination they contributed to the students' course grades. If given as pretests, they allowed students to test their understanding of the material in advance of a tutorial on the topic.

Based on the results from the interviews, a set of five targeted questions about atomic spectra were designed for use in introductory physics courses, both before and after standard instruction. One or more of these questions were given to introductory students at the University of Zagreb and to introductory physics students at the University of Washington.

4. RESEARCH ON STUDENT UNDERSTANDING OF THE ROLE OF THE EXPERIMENTAL SETUP

During informal observations of students in the laboratory course for future physics teachers (Praktikum iz eksperimentalne nastave fizike 2), we observed that students were struggling with trying to understand line spectra. They were often unable to explain the origin or formation of a line spectrum and were attempting to connect line spectra with the diffraction of light through a single slit. Since previous research on student understanding of wave optics had already shown that students have many difficulties with the diffraction of light (Ambrose, Shaffer, Steinberg, & McDermott, 1999), we conducted individual demonstration interviews to probe their reasoning in more detail.

4.1. STUDENT INTERVIEWS ON BASIC SPECTROSCOPIC EXPERIMENTS

The interviews began by showing students an experimental setup consisting of an ordinary incandescent light bulb, a slit (1-2 mm wide) and a screen. Students were asked to predict what they would observe if the bulb were lit. After they had made their predictions and explained their reasoning, the bulb was turned on, and students saw a geometric image of the slit. They were then asked to discuss how, if at all, their observations matched their predictions. (Task 1)

In the second part of the interview, students were asked to predict what they would see on the screen if a prism were inserted between the slit and the screen. After they had made their predictions and explained their reasoning, the experiment was performed. Students were then asked to relate their predictions to the spectrum visible on the screen. (Task 2)

Finally, students were asked to predict what they would see on the screen if the incandescent light bulb were to be replaced by a mercury lamp. As before, the experiment was conducted. The students were then asked how their observation of the discrete spectrum matched their predictions and to explain why there was a discrete, rather than a continuous, spectrum. (Task 3)

4.1.1. CORRECT RESPONSES

The concepts required to answer the tasks discussed above had already been covered in the introductory physics courses. In these courses, both at the University of Zagreb and the University of Washington, students are introduced to geometrical and physical optics and are shown both continuous and line spectra. They are also told about the conditions under which each of the spectra is formed. The students enrolled in the interviews had also completed a laboratory course, in which both single slit diffraction and spectra were covered. They had also taken the quantum mechanics course in which the mathematical formalism and discrete energy states were introduced.

Correct prediction of geometrical image of slit (Task 1): When light falls on a 1 – 2 mm wide slit, a geometrical image of the slit is seen on the screen. The width of 1 – 2 mm slit is sufficiently big compared to the wavelength of visible light that no diffraction pattern is observed. Only geometrical optics needs to be applied. The purpose of this question was to eliminate diffraction from answers on subsequent questions and to help students to focus on spectra and the differences between them.

Correct prediction of continuous spectrum (Task 2): When the prism is inserted between the slit and the screen, a continuous spectrum appears on the screen. The spectrum is displaced from the center of the screen and is due to the dispersion of the white light on the prism. Because the source is incandescent white light, which is an almost ideal grey body, the pattern is continuous.

Correct prediction of discrete spectrum (Task 3): When the incandescent light bulb is replaced by a mercury lamp, a discrete spectrum is observed on the screen. A mercury lamp is a low pressure gas discharge source. When an electron of the excited atom returns to its previous energy state, it releases energy in the form of a photon.

In order to make a correct prediction, students needed only to recognize that light coming from different sources has different properties and that atoms in ionized gases emit only certain discrete wavelengths. Even if they failed to make a correct prediction, it was expected that they could explain the line spectrum that was shown to them after they had made their prediction.

4.1.2. OVERVIEW OF THE RESULTS

Many of the interviewed students failed to predict correctly what would appear on the screen. Even when the patterns on the screen were shown, they often could not interpret their observations.

This section presents an overview of student responses.

(Task 1): Most of the interviewed students (6 out of 9) made the correct prediction that a geometrical image of the slit is seen on the screen. Three students expected the diffraction or interference pattern to appear on the screen. The next excerpt from an interview provides insight into their reasoning:

“I²: Here we have the light source (incandescent bulb), the slit, and the screen. Can you estimate the width of the slit?”

S: 2 mm

I: What do you expect to see on the screen when the bulb is lit?

S: Interference pattern. Now I am not sure if we would see the interference or diffraction.

I: How many slits do you see?

S: One. Then diffraction. One central maximum and lines to the left and to the right of it.

I: Can you explain your reasoning?

S: We have one slit. For interference we would need two slits

I: But why diffraction?

S: Because the light comes to the slit.”

The other student, who predicted an interference pattern, said:

“The light comes to the slit from different direction and on the slit interference happens – superposition of waves that come to the same place. On the places where two crests come together constructive interference is formed and we will see the bright spot and on the places where crest meets trough destructive interference is formed and these are dark spots.”

² I: Interviewer; S: Student

(Task 2): Almost all students (8 of 9) correctly predicted that if the prism is inserted between the slit and the screen, a continuous spectrum appears on the screen. Only one student predicted a discrete spectrum and he/she based the explanation on an observation made in the lab.

(Task 3): Four students correctly predicted that when the incandescent light bulb was replaced by a mercury lamp, a discrete spectrum is observed on the screen. Other students predicted that just one line (violet) would appear on the screen. One student even said that *“mercury lamp radiates in ultraviolet part of spectrum, therefore no line appears on the screen”*. Five students gave the correct explanation for appearance of the discrete spectrum. Other explanations were incomplete and some students didn't even mention energy levels and transitions.

4.2. WRITTEN QUESTIONS ON BASIC SPECTROSCOPIC EXPERIMENTS

Our experience during the interviews led to the design of Written Questions. Question 1EX was administered to 660 students in the regular section and to 85 students in the honors section of the introductory course at the University of Washington. It was also given to 36 introductory students at the University of Zagreb. Question 2EX was administered to 330 introductory students in the regular introductory sequence at the University of Washington, to 50 Intro students at the University of Zagreb, and also to 62 junior students at the University of Zagreb. The groups to whom these two questions were given do not overlap.

Question 1EX was similar to that used in the interviews. It contained a sketch of an experimental set-up consisting of a light source (an incandescent bulb), a mask with a slit of adjustable width, a prism, and a screen. The students were shown the continuous spectrum that would result on the screen. (See Fig. 4-1.) From a list of possible changes, they were asked to select all that could result in a discrete, rather than a continuous, spectrum and

asked to explain their reasoning. The correct option is to replace the bulb by a different type of light source (*e.g.*, a mercury lamp). In Question 2EX, students were shown a portion of a discrete spectrum on the screen and asked what would happen if the prism was removed (See Fig. 4-2.) The correct response is that the lines would become more closely spaced.

The experimental setup at right consists of a light source (an ordinary, incandescent light bulb), a mask with a single slit of adjustable width, a glass prism, and a screen. The screen is far from the prism. When the bulb is lit, a continuous spectrum appears on the screen as shown.

Which of the changes to the setup that are below could result in a *discrete*, rather than a continuous spectrum?

- Changing the width of the slit. Explain.
- Replacing the prism by an optical grating. Explain.
- Replacing the light bulb by a different type of source. Explain
- Changing the distance of the prism to the screen. Explain.
- Removing the prism. Explain.

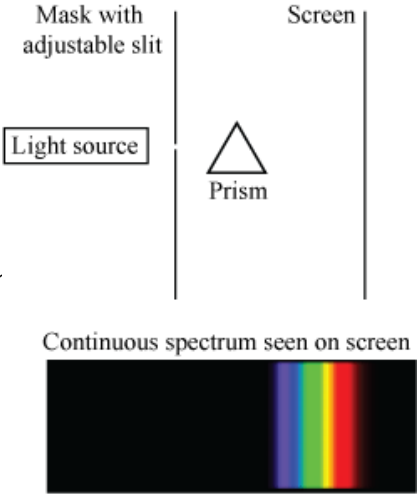

Figure 4-1 The experimental setup problem: Question 1EX

The picture below shows a portion of the discrete spectrum that appears on a very large screen. The colors are not shown in the black and white picture. The spectrum is obtained by using a setup consisting of a gas-discharge light source, a single slit and a glass prism.



What would happen if the prism was removed?

- The lines would become more closely spaced.
- The lines would remain the same.
- The lines would stay on the same location, but all would have the same color.
- The lines would vanish and be replaced by a single bright spot on the center of the screen.
- The lines would vanish and would be replaced by a single bright spot that spans the region where the lines had been.

Figure 4-2 The experimental setup problem: Question 2EX

4.3. RESULTS

During the interviews at the University of Zagreb, junior physics majors were shown arrangements of light sources, slits, prisms, and diffraction gratings, and asked about the patterns that would be produced on the screen. Most gave incorrect answers, despite having completed a prior laboratory course in which spectroscopy was introduced. The results from written questions 1EX and 2EX, which are similar to the interview questions, demonstrate that the difficulties observed in interviews are widespread.

In students' answers to written questions these difficulties were even more pronounced. Most of the students had serious problems with the first question. The results for this question are shown in Tables 4-1 and 4-2. Although between 45% and 60% of students stated that replacing the light bulb by a different type of source would result in a discrete rather than a continuous spectrum, only between 20% and 30% recognized that this was the only change in the set-up that could produce a discrete spectrum. Table 4-1 shows separately the results for each class and each group of students.

Table 4-1 Percentages of students who selected each option in Question 1EX. Last line shows percentages of students who realized that only replacing the source would result in a discrete spectrum.

	CRO INTRO 2011 36	UW123A SPRING 2010 127	UW123A WINTER 2011 230	UW123AC SPRING 2011 300	UW123B SPRING 2010 48 (older v.)	UW123B SPRING 2011 37
Width of the slit	35%	39%	36%	34%	25%	7%
Diffraction grating	35%	61%	56%	47%	50%	28%
Replacing the source	45%	53%	60%	64%	69%	44%
Distance prism screen	20%	29%	36%	22%	4%	4%
Removing the prism	15%	50%	41%	21%	0%	7%
All correct – ONLY REPLACING THE SOURCE	30%	6%	17%	29%	27%	30%

Question 2EX was not so challenging, but some students still struggled with the role of the prism in the experimental setup. The results are shown in Table 4-2, and the most interesting student explanations and specific difficulties are discussed in the next section.

Table 4-2 Results from question 2EX, in which students were asked about how a discrete spectral line pattern would change if the prism were removed from the optical setup.

	UW 123 Regular N = 330	CRO INTRO N = 50	CRO JUNIORS N = 62
The lines would become more closely spaced	12%	36%	5%
The lines would remain same or would have the same color	10%	10%	13%
The lines would be replaced with a single bright spot in the center	45%	45%	70%

4.4. SPECIFIC STUDENT DIFFICULTIES

Many students had significant difficulties in answering the questions described in the previous section. The explanations they gave provide insight into their ideas about line spectra and the role of the optical devices used to observe them.

The most common conceptual and reasoning difficulties are discussed below. For convenience, they are organized according to the optical instruments that were used to elicit them. These specific difficulties are grouped into several broad categories. These groupings, however, are not mutually exclusive, and individual student responses can often be interpreted in more than one way. Some difficulties arose when students were reasoning about more than one optical instrument. In addition, some of the answers indicate an underlying lack of understanding of interference and diffraction.

4.4.1. Difficulties associated with the prism

In Written Questions 1EX and 2EX, students were asked about the effect of removing a prism from an optical experiment. In Question 1EX, the spectrum was continuous before the prism was removed; in Question 2EX, the original spectrum was discrete. In Question 1EX, they were also asked about the impact of changing the distance from the prism to the screen. The responses to these questions gave insight into how the students were thinking about the two different types of spectra and the role of the prism.

a) Treating a prism as if it always yields a continuous spectrum

In their explanations for Question 1EX, many student answers suggested a belief that light passing through a prism yields a continuous spectrum no matter what the light source.

“The prism will still separate light into a continuous spectrum.” [UW Intro]

“The spectrum is produced by the prism, not the light source.” [UW Intro]

About 40% of the students made this error. Some used this reasoning consistently throughout Question 1EX, which yields correct answers to parts A, B, C, and D but with incorrect reasoning. For example, in part A, some students correctly stated that the pattern remains continuous when the width of the slit is changed but their explanations focused on the prism. They did not seem to recognize that the source was producing a continuous spectrum of light.

b) Treating spectral lines as if they are always visible

The most common incorrect answer to Question 2EX was to state that the spectral lines on the screen would remain visible when the prism was removed. Most stated that the lines would become more closely spaced. Some students related the lines to diffraction, but others seemed to think that the lines are always visible in light from an ionized source.

“The prism is bending the light that is going through the single slit. Thus light with differing frequency is separated respectively to its value. With the removal of the prism, this separation still occurs but it is less obvious with the absence of the prism as the prism was just further separating the differing color frequencies.” (UW Intro)

These students did not recognize that without the prism, each wavelength of light from the source would illuminate the same part of the screen and thus the lit area would appear somewhat white in color.

4.4.2. Difficulties associated with a single slit or diffraction grating

In Question 1EX, two of the proposed changes to the experimental setup were: (1) narrowing the slit through which the light passes before reaching the prism and (2) replacing the prism by a diffraction grating.³ In both cases many of the students answered that diffraction could be responsible for forming a discrete line spectrum from a source that has a continuous spectrum.

a) Confusing line spectra with diffraction patterns

Some students incorrectly stated that one or both of the changes above would make the continuous spectrum become discrete. They did not seem to be distinguishing between discrete spectra and diffraction patterns. Interpretation of their responses was made difficult by the fact that some did not seem to know what was meant by a ‘discrete’ or a ‘line’ spectrum,³ despite these terms having been introduced in class. Other students did not seem to distinguish between these two phenomena.

“Optical grating has mins/maxes instead of a continuous spread.” (UW Intro)

“The optical grating would cause interference patterns that could result in a discrete spectrum.” (UW Intro)

³ Almost none of the students recognized that the diffraction patterns produced by a single slit or grating would be complicated by the fact that the incoming light consisted of a range of wavelengths. Most seemed to be thinking of the pattern that would result from light of a single wavelength.

“The grating would make the light that passes it discontinuous so the spectrum on the screen will become discrete.” (UW Intro)

These students seemed to recall that a diffraction grating yields a pattern of bright and dark regions but they incorrectly associated this pattern with a discrete line spectrum.⁴

b) Treating a continuous spectrum as if it consists of a finite series of colors

In their answers to Question 1EX about narrowing the slit or replacing the prism with a grating, some students gave answers that suggested that they were thinking of a continuous spectrum as consisting of a finite number of wavelengths. They stated that the impact of narrowing the slit or adding a diffraction grating would be to ‘widen the beam’ and thus create a discrete pattern.

“Narrowing the slit would create a wider beam so it would spread out the image on the screen creating a discrete pattern.” (UW Intro)

“An optical grating would help create a discrete spectrum, as it acts as many multiple slits, separating different wavelengths.” (UW Intro)

“The optical grating separates the light depending on their wavelengths.” (UW Intro)

“The narrower the slit, the greater the distance between maxima and maxima and we will get line spectrum. And if we make the slit wider the spectrum will remain continuous.” (Cro Intro)

Some of these students seem to have been thinking that the original, continuous spectrum consisted of a finite number of regions, each with a specific color (*e.g.*, green, blue, red, *etc.*). Thus, widening the pattern would give a finite number of regions, each corresponding to a specific wavelength.

⁴ Interpretation of student responses was also complicated by the fact that a complicated pattern would appear on the screen corresponding to diffraction of white light. Almost no students, however, seemed to recognize that

c) Treating line spectra as arising only from monochromatic sources

Almost 20% of the students said that a discrete pattern would be formed if the new source were monochromatic.

“Replacing the light bulb with a monochromatic light source would result in a discrete spectrum because only one wavelength of light would be present.”(UW Intro)

“This would result in a discrete spectrum because you are now only dealing with one wavelength of light instead of a combination of wavelengths - white light in a light bulb.” (UW Honors)

Although this change would produce a discrete pattern (only one line would be seen on the screen). These students did not seem to recognize that they had studied other ways in which a discrete pattern can be formed.

5. RESEARCH ON STUDENT UNDERSTANDING OF ENERGY LEVELS AND TRANSITIONS

Already in the first part of the interview students failed to explain the formation of line spectra observed on the screen. The purpose of the second part of the interview was to probe student reasoning about energy levels and transitions in more detail.

5.1. STUDENT INTERVIEWS

The second part of the interview started by showing students two different spectra (Figure 5-1) and asking them to account for the differences between spectra.

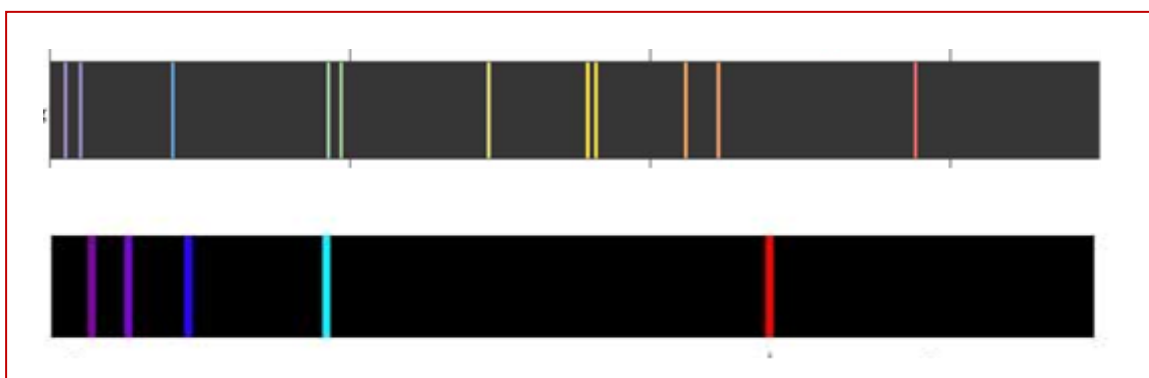

Figure 5-1 Two different line spectra shown to students during the interview

It was expected that students would recognize that these two spectra were different because they came from two different sources. The intention was to get the students to start talking about energy levels and the light source, if they hadn't already used those concepts when explaining the origin of the line spectrum. Students were also asked to connect the wavelength of each line with its energy.

The next task for the student, concerning Figure 5-1, was to select the line which corresponds to transition between the two closest energy levels. It was expected that students would recognize that the transition between the two closest energy levels

corresponds to the smallest energy, *i.e.*, to the line with the greatest wavelength, which is in the case of both spectra in Figure 5-1 the red line.

Finally, we asked students if the lines in the spectrum extended to infinity on the left and the right end of spectrum. This was the most demanding task, as it required that students recognize that the largest possible difference in energy is between the unbound state and the ground state, which corresponds to the smallest wavelength and thus the last (or first) line at the left part of the spectrum. The right part of the spectrum corresponds to large wavelengths and small differences in energy levels. Because the energy levels become more and more closely spaced when approaching the unbound state, arbitrarily large wavelengths are possible and thus lines could extend to infinity at that part of the spectrum.

At the end of the interview, students were shown the energy level diagram and asked how many spectral lines could possibly be obtained from just those four levels. This question was intended to force students to start thinking about energy levels, if they hadn't done that before. We also wanted to probe whether they realized that one line is formed as a result of a transition between two energy levels.

5.2. WRITTEN QUESTIONS ON ENERGY LEVELS AND TRANSITIONS

Part of the interviews were devoted to questions that probed student thinking about discrete line spectra and atomic energy levels, as well as the connection between them. Two questions were used in both the interviews and the written questions. One question was used only in written form. All three questions are discussed below and the results are discussed in the following section.

Question 1EL: Students were shown an energy level diagram consisting of the four lowest energy levels for a particular source (Fig 5-2). They were asked to state how many spectral lines could possibly be obtained from just those four levels. We expected students to recognize that the basic model presented in class and the textbook allows for transitions between any two, different

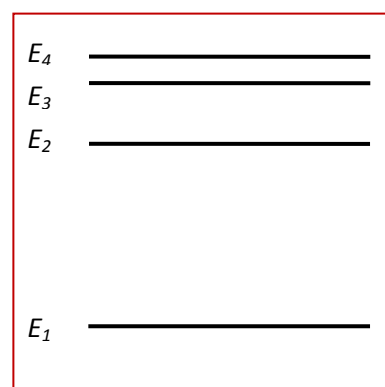
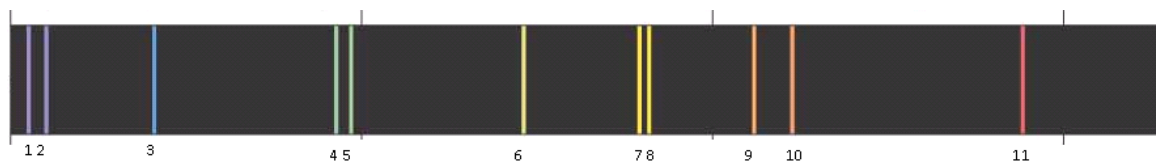

Figure 5-2 Energy level diagram for Question 1EL

energy levels. Thus, there are three possible transitions from the highest energy level, two transitions from the second highest energy level, and one from the second lowest energy level - yielding a total of 6 transitions. This question was used in interviews and as an exam question after standard instruction to 500 introductory UW students.

Question 2EL: Students were shown a photograph of a discrete line spectrum and asked to identify the line (or lines) that correspond to the transition between the two closest energy levels in the atoms of light source (Fig 5-3). We expected students to recognize that lines corresponding to the transition between the closest energy levels would have the smallest energy and thus the largest wavelength. This question, which appeared both as a question in interviews and as a written question, proved to be very difficult.

The diagram below shows the visible part of the spectrum of a particular gas.



Which of the line or lines above correspond(s) to a transition between the two closest energy levels? (Consider only the energy levels involved in the formation of the lines shown above.)

Figure 5-3 Lines and energy levels: Question 2EL

Question 3EL: In this question, which was used only in written form, students were shown the visible part of a discrete spectrum and asked to identify the minimum number of energy levels required for a source to produce this part of the spectrum (See Fig. 3.). The spectrum in the figure consists of 11 spectral lines, and students were expected to recognize that this corresponds to 11 transitions, and in order to have 11 transitions 6 energy levels are needed.

The diagram below shows the visible part of the spectrum of a particular gas.

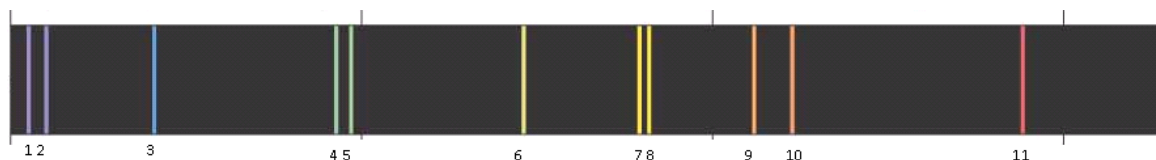

What is the minimum number of energy levels in each atom of the gas that could produce the given lines in this spectrum?

Figure 5-4 Lines and energy levels: Question 3EL

Questions 1EL and 2EL were used in the interviews with 9 junior level physics majors at Zagreb. All three questions were used later in written form. They have been given after lecture-type instruction on spectroscopy to 92 students at University of Zagreb, to 71 honors students at University of Washington, and to 720 students at University of Washington.

5.3. RESULTS

Questions 1EL–3EL explicitly probe student ability to relate discrete spectra to transitions between energy levels and *vice versa*. These questions proved to be difficult for many students. 300 UW students answered all three questions. Other students in the study answered only some of the questions. As can be seen in Table 5-1, performance was strongest on question 1EL, in which students were asked to determine the maximum number of spectral lines that could result from just the four lowest energy levels for a given source. About half of the introductory students at UW answered the written version of the question correctly, as did 75% of the students at the University of Zagreb during the interviews.

Students did less well on questions 2EL and 3EL. Only 10%–20% of the introductory students at both institutions answered both questions correctly. Even the junior-level physics majors in Croatia had difficulty – only 30% answered correctly. The results are similar to those from interviews, for which about 25% of the students answered question 2EL correctly.

Although the questions were given after standard instruction on formation of line spectra, only between 5% and 20% of the students answered both Questions 2EL and 3EL correctly, thus indicating poor understanding of the process of line spectrum formation.

Table 5-1 Percentages of correct answers for Questions 1EL, 2EL and 3EL

	UW123AC Spring 2011	UW123AC Winter 2011	UW 123A Autumn 2009	CRO INTRO 2010, 2011	UW123B HONORS 2010, 2011	CRO JUNIORS 2010
Number of students	300	230	190	92	71	62
Question 1EL	55%		55%			
Question 2EL	20%	15%		10%	30%	35%
Question 3EL	30%	20%		15%	45%	50%
Question 2EL & 3EL	15%	10%		10%	20%	30%

The next two tables: Table 5-2 and Table 5-3 show distribution of students' answers for questions 2EL and 3EL separately.

Table 5-2 Distribution of student answers on Question 2EL

	CRO INTRO 2010	CRO INTRO 2011 36	UW123A WINTER 2011 230	UW123AC SPRING 2011 300	UW123B SPRING 2010 48	UW123B SPRING 2011 37	CRO JUNIORS 2010 62
1		3%	3%	5%	6%	11%	2%
1 and 2		3%	11%	9%	6%	5%	3%
7 and 8	50%	42%	60%	52%	40%	38%	45%
10 and 11		0%	5%	7%	8%	8%	3%
11	10%	22%	13%	22%	27%	38%	35%

It can be seen from Table 5-2 that most of the students identify the two closest energy levels with the two closest lines in spectrum. Between 40 % and 60 % of students made that mistake. Table 5-3 shows that just a slightly lower fraction of students identified the number of lines in the spectrum with the number of energy levels (answer 11 in Table 5-2). The second most frequent incorrect choice was 5 energy levels. This error reveals another difficulty, as will be seen later.

Table 5-3 Distribution of student answers on Question 3EL

	CRO INTRO 2010	CRO INTRO 2011 36	UW123A WINTER 2011 230	UW123AC SPRING 2011 300	UW123B SPRING 2010 48	UW123B SPRING 2011 37	CRO JUNIORS 2010 62
5		8%	12%	16%	19%	11%	
6	10%	20%	18%	32%	42%	46%	50%
8		0%	5%	5%	2%	5%	
10		0%	7%	5%	4%	0%	
11		30%	54%	41%	21%	35%	

5.4. IDENTIFICATION OF SPECIFIC DIFFICULTIES

We have found the research tasks described in the previous section useful for probing student ability to relate spectral lines and energy levels. During the interviews, we observed that students often did not understand the connection between spectral lines and energy levels, and when they did, they associated one line with one energy level, and not with the transition between two energy levels. Only 45 % of the interviewed students even mentioned energy levels in their answers when they were trying to explain the origin of the line spectrum.

The set of Questions 1–3EL revealed a variety of incorrect ideas about spectral lines and energy levels and about the relationship between them. In the following discussion, the errors are organized into categories to make explicit the conceptual and reasoning difficulties that were identified. The goal was to organize the findings so that they could be of use to instructors interested in improving instruction and in developing curriculum. Note, however, that many of the ideas are inter-related and cannot be completely separated from one another.

5.4.1. Associating each line in a spectrum with a single energy level in the source

The most frequent error made by students was to treat the lines in a discrete spectrum as if they were in a one-to-one correspondence with the energy levels in the source. About half of the students made this error on Questions 2EL and 3EL. On Question 3EL, for example, many students said that 11 energy levels are required in the source to produce the 11 lines in the discrete spectrum.

“Each energy level will create its own emission line. There are 11 emission lines, so there must be 11 energy levels.” (UW Honors)

“To each line corresponds one energy level.” (Cro junior)

“Each line corresponds to a different photon being released out of the atom at a different energy state, thus each different line is a different energy level.” (Cro junior)

This error also arose on Question 2EL. Between 40% and 60% of the students associated the two closest lines in the spectrum (lines 7 and 8) with a transition between the two closest energy levels in the source.

“The distance between bands 7 and 8 is the shortest; therefore their energy levels are closest to one another.” (UW Intro)

5.4.2. Equating the energies of the spectral lines and those of the energy levels in the source

A sub-set of the students who made the previous error seemed to think that the energy of the photons associated with each spectral line ($h\nu$) is equal to the energy of one of the energy levels in the source. Some were explicit in their reasoning; for others this error was implied.

“ $E = h\nu$. That means one wavelength equals one energy level, i.e., one energy level is one photon with definite energy, i.e., wavelength. (Cro Junior)

“7 and 8 are the closest in proximity to each other which means their wavelengths are the most similar and so also their energy levels.” (UW Intro)

5.4.3. Focusing on the number of distinct colors in a line spectrum, not the total number of lines

In answering Question 3EL, some students used the number of visibly distinct colors in the spectrum, not the number of lines. They recognized that the spectrum has 11 lines, but stated that there are only 6 distinct colors. They then used the number of colors to find the number of energy levels.

“By counting the color groupings of lines, you can determine the number of energy levels present to produce this spectrum.” (UW Honors)

Many of these students also made the error described previously of associating each line or color with an energy level, rather than with a transition between two levels. This combination of errors led some students to obtain the correct answer for the number of energy levels on question 3 (with incorrect reasoning).

“The number of colors [6] is the number of energy levels [6].” (UW Intro)

“The colors that are specifically different correspond to different spectrum lines.” (UW Intro)

5.4.4. Not treating the ground energy level as an energy level

On Question 3, about 15% of the students incorrectly stated that the minimum number of energy levels needed to produce 11 spectral lines is 5, rather than 6. Many began their explanations correctly: they counted the number of spectral lines resulting from transitions from the first excited energy level to the ground level (1), the number resulting from transitions from the second excited energy level to the first and ground (2), *etc.* They recognized that having four excited energy levels would only give 10 ($= 1 + 2 + 3 + 4$) transitions so five excited energy levels are needed. However, they then answered that only 5 energy levels are required. It did not seem as though most students simply ‘forgot’ to count the ground energy level. Some stated explicitly that the ground energy level should not be counted.

“I think the first one is the ground state so it doesn’t count.” (UW Intro)

5.4.5. Treating atomic transitions as always involving the ground energy level

About 10% of the students who answered Question 1EL incorrectly stated that four energy levels would result in 3 spectral lines (not 6). Many of these students seemed to think that only transitions to the ground level are possible. The following explanation and Figure 5-5 illustrate this error.

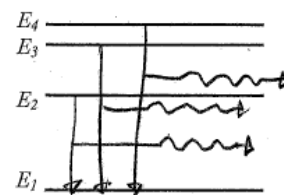

Figure 5-5 Diagram drawn by student for question 1EL.

“Three lines are formed from possible combinations from E_n to E_0 .”
(UW Intro)

5.4.6. Using incorrect models for emission of photons

In Question 1EL, about half of the students correctly recognized that 4 energy levels yield a total of 6 possible transitions. However, only about 15% gave explanations in which they correctly described the emission of light as resulting from an electron changing from one energy level to another (lower) energy level. Most explanations were incomplete. Some students failed to identify the object that was changing from one energy level to another. Others incorrectly identified the object as the photon itself or stated that it was the spectral lines or the states themselves that were changing or ‘dropping.’

“The maximum number of spectral lines is 6 because the photon can drop any number of levels at a time ...” (UW Intro)

“There should be 6 [energy levels] from where each one can jump to each other. States can only jump down.” (UW Intro)

5.4.7. Confusing related concepts

As is evident in some of the previous student responses, students often used the terms *spectral line*, *photon energy*, *energy level*, etc. inappropriately. Many of the explanations suggested an overall failure to distinguish between these related concepts. For example, students described transitions ‘between spectral lines’ rather than between energy levels. It is interesting to note that these responses were often accompanied by incorrect answers, suggesting that the students had several concurrent difficulties.

“The lines 7 and 8 are closest together, so the transitions between these two energies are closest.” (UW Intro)

“They [the 7th and 8th spectral lines] are closest together, so it requires less energy to move from 7 to 8 and 8 to 7.” (UW Intro)

“There are 11 bands so 1 less is the number of energy levels at minimum to create energy drop for each wavelength.” (UW Intro)

In order to try and determine the extent to which these student responses reflected genuine confusion between related concepts, we developed a new written question. (See Fig. 5-6.) In Question 4EL, students were asked to pick from among several choices the explanation that best describes the process by which a line spectrum is formed. The choices were drawn from some of the written responses we had seen for Questions 1-3EL.

Which of the following best describes the process of formation of spectral lines?

Spectral lines are formed when:

- An atom emits an electron to become more stable
- An electron jumps between energy levels in an atom and emits a photon
- A photon drops between energy levels emitting different wavelengths of light
- An atom absorbs a photon
- One energy level drops to the energy level directly below it and emits a photon

Figure 5-6 Question 4EL - Additional question asked of students

The question was administered to 77 students in the standard introductory calculus-based sequence at the UW. About 65% of the students chose the correct answer (b) that spectral emission lines are formed when an electron changes energy levels in an atom and emits a photon. The rest were mostly divided between (c) a *photon* drops between energy levels emitting a wavelength of light (20%) and (e) one *energy level* drops to the energy level

directly below it and emits a photon (10%). The results are consistent with about one-third of the students failing to distinguish between related concepts.

5.5. GENERAL FAILURE TO ASSOCIATE DISCRETE SPECTRA WITH TRANSITIONS BETWEEN ENERGY LEVELS

The specific difficulties described in Chapters 4 and 5 are symptomatic of more general problems. The errors made by the students indicate that many fail to recognize that discrete emission spectra are associated with light composed of only a finite number of wavelengths. Even though discrete spectra are typically introduced to help motivate the idea of energy levels and transitions of electrons between them, few students seemed to understand the connection between these ideas.

5.5.1. Belief that line spectra can be observed for any light source

As illustrated in the Chapter 4, many students thought that continuous and discrete emission spectra can be transformed one-into-the-other by making changes to the optical instruments that are used to observe them. Each of the changes to the experiment that are proposed in Question 1EX in chapter 4 (changing the slit width, replacing the prism by a diffraction grating, changing the prism-screen distance, and removing the prism) was considered by some fraction of the students as a way to produce a discrete spectrum from white light. The responses suggested a wide variety of difficulties associated with the optical instruments themselves. At a more general level, however, they indicated a failure of students to understand that a discrete spectrum is associated with light that has a finite set of wavelengths.

5.5.2. Failure to associate line spectra with atomic transitions

During the interviews with junior physics majors, fewer than half raised the idea of energy levels on their own to account for a discrete line spectrum from an ionized gas. Instead, they attributed the lines to the optical instruments in the experimental setup. The written questions revealed the extent to which students, after instruction, fail to associate the lines in a discrete spectrum with transitions of electrons in the atoms of the source. The results from the interviews demonstrate that this problem is not confined to the introductory level.

6. ADDRESSING DIFFICULTIES WITH ENERGY LEVELS AND TRANSITIONS

Research results presented in previous chapters of this dissertation indicate that many students have difficulties in relating spectral lines with electron transitions between energy levels. Almost 50% of introductory students related one line in a spectrum to one energy level in an energy level diagram. They failed to associate a line in spectrum with transitions of an electron between two energy levels. This chapter describes the development of a tutorial and the methods used to assess its effectiveness. The results are also presented. The instructional context in which the curriculum was designed and tested is described in Section 6.1.

6.1. CONTEXT FOR DEVELOPMENT OF CURRICULUM

The instructional materials described below are intended to be compatible with introductory physics courses. Different universities have different courses formats, but in most cases each introductory physics course consists of lectures and recitation sections (or other activities in a smaller group settings) that supplement the lectures. Some introductory physics courses also have laboratories as an integral part of the course (as at the University of Washington), while at other universities laboratories are separate courses that come after the introductory physics course (as at the University of Zagreb).

Tutorials in Introductory Physics, which has been developed by the Physics Education Group at the University of Washington, serves as a model for the curriculum development described in this dissertation. As already mentioned in Chapter 3.1, tutorials have been used at the University of Washington for many years. The most common format is in small sections in which 20 – 30 students work in a group of three or four for one class period of 50 minutes per week. Regardless of the specific format used, tutorials are usually preceded by a pretest that focuses student attention on the conceptual problems similar to those addressed in the tutorial. On the exams conceptual questions similar to the problems in the tutorials are given to assess the effectiveness of the curriculum (post-test questions).

As already been discussed in previous chapters, two different aspects of student understanding of atomic spectra were investigated. One dealt with the role of optical systems in the formation of a line spectrum and the other dealt with energy levels and transitions. A whole range of different student difficulties was found, and a need for two different tutorials was noted: one focusing on optical systems and the other focusing on energy levels and transitions.

The introductory physics sequence at the University of Washington includes one 50 - minute period tutorial per week. Each week, a different topic is covered in the tutorial sections. Thus, only one tutorial - the one that addresses energy levels and transitions - was administered to students at the University of Washington. The tutorial that addresses optical systems was incorporated in the tutorial homework.

At the University of Zagreb, the general physics course includes three 45 - minute periods of recitations per week. This schedule enabled instructors to spend more time on the tutorials. As a result, both tutorials were administered to introductory physics students at the University of Zagreb. But in Zagreb the tutorial homework was not used. In the next sections tutorials and tutorial homework will be described, as well as the post-test results from different student groups.

6.2. SPECTRA TUTORIAL – ENERGY LEVELS AND TRANSITIONS

6.2.1. REVIEW OF STUDENT DIFFICULTIES

As has been reported in Chapter 5, we found that students often failed to associate a line in a spectrum with a transition of electrons between two energy levels. The most common student error, made by almost 50% of all students, was associating one spectral line with one energy level. Other mistakes included: believing that the ground state is not an energy level, associating the number of distinct colors in a spectrum with the number of energy levels, believing that transitions always take place to the ground energy level, and using an incorrect model for the emission of photons from atoms. The instructional strategies that we designed tried to address these difficulties. After having completed the tutorial and the

tutorial homework, students were expected to be able to associate one line in the spectrum of hydrogen with a transition of electrons between two energy levels and to sketch the energy level diagram for hydrogen based on its spectrum. Students were also expected to recognize that the highest energy of the electron – proton system equals zero and that energy levels become closer together when approaching that limit. They were also expected to associate a particular line in the spectrum with the respective transition between two energy levels.

6.2.2. DESCRIPTION OF INSTRUCTIONAL STRATEGIES

The instructional materials described below are intended to be compatible with the lectures in the introductory physics course. Tutorials have been used in small group settings, but also as interactive tutorial lectures in a class with 250 students.

At the beginning of the tutorial, students are presented with a hypothetical student dialogue (Figure 6-1), in which one student expresses the idea that the line at the far right corresponds to the highest energy level. The reply from the second student expresses the frequently held idea that the line at the far right corresponds to the ground energy level.

- A. A hydrogen lamp is placed in front of a mask with a 1 mm slit. A prism is between the mask and a screen as shown. The pattern shown is observed on the screen. (The rightmost line is red. The leftmost line is violet.)

Consider the following discussion.

- Student 1: “The line at far right has the largest wavelength, which means the largest frequency. So that line corresponds to the highest energy value and represents the highest energy level of hydrogen.”
- Student 2: “I disagree. The energy of one energy level equals hf and frequency is inversely proportional to wavelength. That means that the line at the far right corresponds to the ground energy level.”

With which student, if either, do you agree? Explain your reasoning.

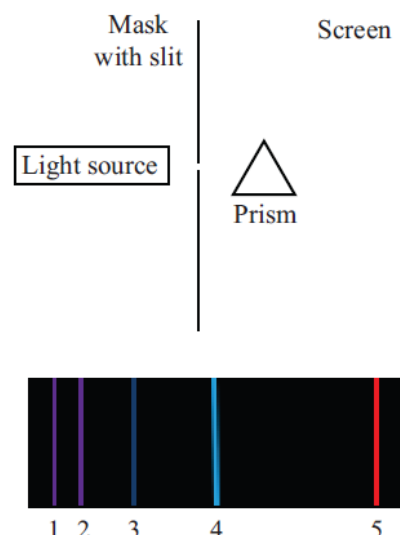

Figure 6-1 Curriculum segment with use of student dialogue

The goal of this part of the tutorial is to focus student attention on the problem of energy levels and transitions and to force them to agree or disagree with the students. Students are encouraged to write down their answers and reasoning and to formulate their ideas, even if they are wrong. After having completed the second part of the tutorial, students are asked to return to this question, and to reflect on their previous answers.

The next two problems guide students in finding the algebraic relationship between the wavelengths of the observed lines and the energy levels in the diagram. First, they are asked to calculate the energy of the photons that form the lines shown in Figure 6-2.

- B. The table below shows the measured wavelengths of the lines in the spectrum above. Use the information provided to calculate the energy of the photons that form these lines. Fill in the third column of the table with the photon energies in electron volts. (Planck constant, $h = 6.62 \times 10^{-34}$ Js, speed of light, $c = 3.0 \times 10^8$ m/s, $1 \text{ eV} = 1.6 \times 10^{-19}$ J)

Line Number	Wavelength	Photon Energy (from Part B)	Formula relating photon energies to energy levels (answer after completing Part C)
2	410.2 nm		
3	434.1 nm		
4	486.1 nm		
5	656.3 nm		

Figure 6-2 Curriculum segment designed to help students to relate lines in spectrum with transition between energy levels in atom

After they have calculated the photon energies, students are asked in the next question to find the formula connecting photon energies with the energies in the energy level diagram (Figure 7-3). Afterwards, based on the formula they have found, they need to describe what happens in a hydrogen atom when a photon is emitted.

C. The diagram at right shows some of the energy levels for an electron in a hydrogen atom. The energies are calculated from the Schrödinger equation.

How are the energies in the diagram algebraically related to the photon energies in the third column in the table in part B?

On the basis of your answer above, complete the fourth column in the table.

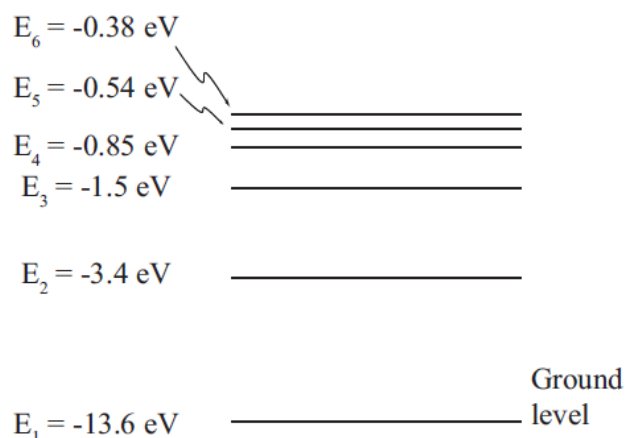

(Spacing not to scale)

Figure 6-3 Curriculum segment designed to help students to relate lines in spectrum with transition between energy levels in atom

It is expected that students will realize that each line is formed as the result of the transition of electrons between two energy levels. This curriculum segment was designed to help students associate one line in the spectrum with a transition between two energy levels in the atom. After completion of this segment, students are expected to be able to apply the formula for the transition between two energy levels: for a simplified case of hydrogen-like atoms. At this point students are asked to return again to the discussion between two students, presented at the beginning of the tutorial, to state if they agree with their previous answer, and if they disagree with the students to identify what is incorrect in their statements.

During the tutorial sessions, it was observed that about 50 % of the students agreed with student 2 at the beginning of the tutorial. However, almost all of the students recognized that this statement was incorrect after completing parts B and C of the tutorial. Most of the students didn't have a problem in finding the formula that connects numbers in the table in part B (photon energies) with the energies in the energy level diagram. Most of them remembered from the lecture that they needed to subtract two numbers obtained from the energy level diagram. They had more problems with the interpretation of what happens to

the hydrogen atom when a photon is emitted. Additional discussion developed in the groups on that matter.

The second part of the tutorial focuses on the pattern of lines in discrete spectra. Students calculated the ratio between the ground energy level and the excited levels in order to recognize that $E_1 : E_n = n^2$. This should have helped them realize that there is a limit to the highest energy of the electron – proton system, and to later sketch the energy level diagram with qualitatively correct spacing between energy levels for a spectrum consisting of 6 spectral lines. Finally, students were asked if they would expect (based on the ideas developed in the tutorial) spectral lines to extend to infinity on the left and the right part of spectrum.

Most of the students were able to come to the equation $E_1 : E_n = n^2$ without additional help, but some guidance was necessary on the question that asked which transition corresponded to the line with photon energy 3,4 eV. Students were expected to recognize that this line is formed when an electron jumps from energy level $E_\infty = 0$ eV to $E_2 = -3,4$ eV. When sketching the energy level diagram for a spectrum consisting of 6 spectral lines, students easily recognized that they needed to sketch 4 energy levels, but they had more problems in sketching the qualitatively correct spacing between energy levels. Tutorial instructors encouraged the discussion about the spacing between energy levels and about the influence of the ratio of E_1 to E_n on the distance between energy levels. This curriculum segment was designed to help students recognize that the highest energy of the electron – proton system equals zero and to recognize that energy levels become closer and closer together when approaching that limit. The question that asked students if they would expect spectral lines to extend to infinity on the left and the right part of spectrum tried to help them to think about the smallest possible wavelength, i.e. the greatest possible spacing between two energy levels, and about the largest possible wavelength, and thus the smallest possible spacing between two energy levels. This question, together with the question about the transition that corresponds to the line at the far right in the spectrum with 6 spectral lines, tried to help students to associate spectral lines with the respective transitions of electrons between energy levels. The whole tutorial on energy levels and transitions is given in Appendix A – 1.

In tutorial lectures, similar worksheets were used (Appendix A – 2), but instead of the discussions in groups of three or four students, the whole class was stopped for the class discussion at the denoted checkpoints. Clicker questions were used to probe student understanding after each part of the tutorial and to motivate the class discussion.

Homework was designed to accompany the tutorials. As has already been discussed, the first part of the homework focused on the experimental setups and on different patterns observed on the screen. The other part of the homework focused on the energy levels and transitions. Two different versions of the homework were developed (Appendix A – 3 and A – 4).

Both homework versions asked students to predict whether the corresponding lines in the spectrum of singly ionized helium would be at the same places as the lines in the spectrum of hydrogen or further to the left/ further to the right (Figure 7-4).

The energy levels for hydrogen-like atoms (*e.g.*, atoms with a single electron) can be written as $E_n = Z^2 E_0 / n^2$, where E_0 is the energy of the ground level for hydrogen and Z is the number of protons in the atom.

The diagram below shows part of the line spectrum for hydrogen. (Wavelength increases to the right.)



Would you expect the corresponding lines for singly ionized helium to be *at the same places as the lines for hydrogen, further to the right, or further to the left?* Explain your reasoning.

Figure 6-4 Curriculum segment from tutorial homework

This homework segment was designed to make students think about the spacing between energy levels as well as about transitions between energy levels. In order to answer this question correctly students needed to recognize that for singly ionized helium $Z = 2$, and thus the ground energy level of helium is four times lower than the ground energy level of hydrogen. If they continue to compare energy levels of helium and hydrogen, students can recognize that the first excited energy level of helium has the same energy as the ground

energy level of hydrogen. In this way they can compare values for all energy levels. The next step that students need to take is to look at transitions between energy levels for hydrogen and the transitions between the corresponding energy levels for helium. Because of the Z^2 in formula for E_n the energy levels for helium have a lower value than the corresponding energy levels for hydrogen. Thus the difference between the two corresponding energy levels is greater, and the helium lines are further to the left in the spectrum than the hydrogen lines.

The second homework question focused on the absorption spectrum (Figure 6-5). Students were shown the experimental setup consisting of an incandescent light source, a slit, a container of hydrogen gas at room temperature, a prism and a screen. They were asked to account for the observation that some wavelengths are not visible in the spectrum on the screen. In the second part of the question, the wavelengths of the missing lines were given and students were asked to calculate the energies in the energy level diagram for hydrogen.

A glass container holds hydrogen gas at room temperature. At this temperature, most of the atoms are in the ground state. (The ground state energy of hydrogen is -13.6 eV.)

White light from an incandescent bulb is incident on the container as shown on the picture at right. (Light from this source appears continuous in the visible part of the spectrum.)

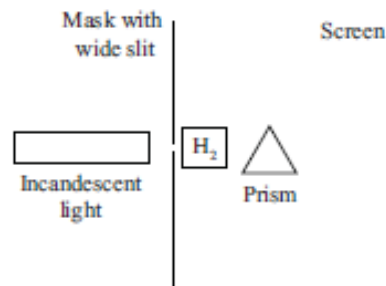

- a. It is observed that certain wavelengths are not visible in the spectrum on the screen. How can you account for this observation? Explain your reasoning.

- b. The table at right shows some missing wavelengths.

Based on the fact that the hydrogen gas is at room temperature, use the table at right to calculate a few of the energy levels for hydrogen. Explain your reasoning. Express your answers in electron-volts.

λ (nm)
121.6
102.5
97.2
94.9

Figure 6-5 Curriculum segment from tutorial homework

Students were expected to recognize that the hydrogen gas absorbed missing wavelengths and that these wavelengths correspond to transitions between the ground level and the upper energy levels. From these conclusions, students were expected to calculate the energies of energy levels. This question tended to remind students of the transitions between energy levels in a slightly different context.

6.3. ASSESSMENT OF INSTRUCTIONAL STRATEGIES

In order to assess the effectiveness of the curriculum, we administered several written post-tests. These tasks were given as exam questions. The tasks were designed to probe the extent to which students had developed a functional understanding of the material. The criterion for achievement of a functional understanding of the material is that students are able to apply the concepts addressed in the curriculum in a somewhat different context from the one in which the concepts were learned. Therefore, the post-test questions are designed in such a way that student are not able to answer them by simply memorizing the answers to questions posed in the instructional materials.

6.3.1. POST-TEST QUESTIONS AND THE RESULTS

The post-test questions were designed to check if the tutorial helped students to develop a functional understanding of the material. The tutorial on energy levels and spectra was used with 100 introductory students at the University of Zagreb, 530 introductory students at the University of Washington in regular sections and 87 Honor students at the University of Washington. The interactive tutorial lecture was used with an additional 250 introductory students at the University of Washington.

Three slightly different versions of the same post-test question were developed.

In the first part of all three questions, students were asked to sketch the energy level diagram with the minimum number of energy levels required to produce the number of spectral lines given on the diagram.

A summary of student responses to each post-test problem after tutorial instruction is presented in Section 6.3.1.1. These results are compared to those obtained before instruction.

6.3.1.1. Post-test question one

Post-test question 1 was administered as part of the third course exam at the University of Washington and also on the exam at the University of Zagreb. At the time of the exam students at the University of Zagreb have completed the tutorial on energy levels and transitions and students at the University of Washington have completed both the tutorial and the tutorial homework on energy levels and transitions.

Review of Post-test question one: This question probes student ability to relate lines in spectrum to transitions between energy levels. The students were shown a part of the line spectrum for hydrogen, consisting of 10 spectral lines. They were asked to sketch the minimum number of energy levels required to produce the given spectrum (i). In the second part of the question, students were asked how many new lines would be formed in the spectrum if one additional energy level were added. They were also asked to sketch the position of the two left-most lines on the spectrum diagram (ii). The wording of the tasks and the diagram presented to the students are reproduced in Figure 7-6.

This problem consists of two independent parts, A and B.

A. The diagram below shows part of the line spectrum for hydrogen. (λ increases to the right.)



$\lambda \rightarrow$ increasing

- i. In the space at right, sketch the energy level diagram for hydrogen. Show **only** the minimum number of energy levels required to produce the number of spectral lines given above. The spacing between the energy levels should be qualitatively correct. Briefly explain your reasoning.



- ii. Suppose you were to add one additional energy level to your diagram.

- a) How many new lines would be formed on the spectrum? Explain briefly.
- b) If you think new lines are formed, sketch the locations of the two leftmost new lines on the diagram below. If only one new line is formed, then indicate the location of that single line. Explain briefly.



$\lambda \rightarrow$ increasing

Figure 6-6 Post-test question 1

Correct response: (i) The spectrum in Figure 7-6 has 10 lines, which correspond to 10 transitions. Two energy levels give one transition; adding a third level adds another 2 transitions; adding a fourth energy level gives another 3 transitions and adding a fifth gives another 4 transitions. Thus, for 10 transitions 5 energy levels are needed.⁵ (The distance between energy levels decreases with n^2 .)

(ii) The next energy level (the sixth), in conjunction with the original 5 energy levels, gives rise to 5 new lines in the spectrum (5 transitions, one to each of the other energy levels).

Positions of the newly formed lines can be determined by looking at the specific transitions between energy levels. The transition from E_6 to E_1 has a larger energy difference than any of the original transitions. This transition corresponds to a photon of the smallest

⁵ Students were not expected to raise the issue of selection rules that might prevent transitions between some of the levels. If they had, their answers would have been counted as correct.

wavelength, and so the corresponding line on the spectrum is to the left of all the original lines. The next new line on the left corresponds to the transition from E_6 to E_2 . The energy of that transition is smaller than the energies of all transitions to E_1 , but larger than all the other transitions. Hence, the line corresponding to that transition is to the right of all the lines resulting from transitions to the ground level. Thus, it is to the right of the first four lines that were originally on the diagram.

Results: After completing the tutorial, about 90% of the students sketched the correct number of energy levels (with correct reasoning) needed for the spectrum consisting of 10 lines. This is a considerably higher fraction than on the similar pretest questions (research questions 2 and 3 in Chapter 5) given in the introductory physics course after the standard lecture on spectroscopy (30%) and also a higher fraction than the one obtained from junior students at University of Zagreb (50%). The results from the Task (i) from Posttest question 1 are summarized in Table 6-1.

Table 6-1 Results from task (i) after tutorial instruction compared with the pretest

	CRO Intro N = 100 AFTER TUTORIAL	UW Honors N = 52 AFTER TUTORIAL	CRO Intro N = 100 PRETEST	UW Honors N = 52 PRETEST	CRO JUNIORS N = 62
Task (i) Energy level diagram consists of 5 energy levels	85 %	95 %	10 %	30 %	50 %

In task (ii), about 80% of the students correctly concluded that 5 new lines in the spectrum are formed when one new energy level is added. The fraction of students who correctly sketched the position of the new lines was somewhat smaller and varied between 15% and 45%. The results from task (ii) are summarized in Table 6-2.

Table 6-2 Results from task (ii) after tutorial instruction

	CRO Intro N = 100 AFTER TUTORIAL	UW Honors N = 52 AFTER TUTORIAL
Task (ii): one new energy level gives rise to 5 new lines	65 %	90 %
Task (ii): correct position of the two leftmost new lines	15 %	45 %
Task (ii): correct position of only one line	30 %	85 %

6.3.1.2. Post-test questions two and three

In order to prevent students from answering questions by just memorizing answers to previously given questions, the same examination question was not administered more than once in the same course. The second and third post-test questions were developed and administered to 388 introductory students who had completed the tutorial on energy levels and transitions.

Review of Post-test question 2: The students were again shown a part of the line spectrum for hydrogen consisting of 10 spectral lines. They were asked to sketch the minimum number of energy levels required to produce the given spectrum. The space intended for the energy level diagram included a line representing 0 eV to probe if students recognize that the energy of the energy levels is negative (i). In the second part of the question, students were asked in how many of the spectral lines is energy level E_2 involved. They were also asked to circle those lines in the spectrum diagram (ii). The wording of the tasks and the diagram presented to the students are reproduced in Figure 6-7.

This problem consists of two independent parts, A and B.

A. The diagram at right shows part of the discrete line spectrum for hydrogen. (λ increases to right.)

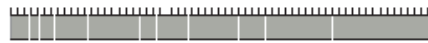

i. [5 pts] In the space at right, sketch an energy level diagram for hydrogen that shows **only** the minimum number of energy levels required to produce the 10 lines above. Assume that only the lowest energy levels are involved in creating these lines. Label the levels E_1 (for the ground state), E_2 (for the first excited state), etc. The spacing between the energy levels should be qualitatively correct. Briefly explain.

$\lambda \rightarrow$ increasing

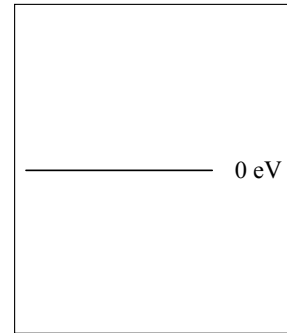

ii. [10 pts] The energy level E_2 is involved in the formation of one or more of these lines. How many? Circle those lines in the diagram at right. Explain.

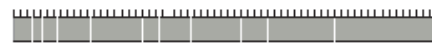

$\lambda \rightarrow$ increasing

Figure 6-7 Post-test question 2

Correct response: (i) The spectrum in Figure 6-7 has 10 lines that correspond to 10 transitions. Two energy levels give one transition. Adding a third level adds another 2 transitions. Adding a fourth gives another 3 transitions, and adding a fifth gives another 4 transitions. Thus, for 10 transitions, 5 energy levels are needed. Since $E_1/E_n = n^2$, the distance between energy levels decreases with n^2 . Since the energies are negative, all energy levels are below the line representing 0 eV.

(ii) The first four lines on the left have the smallest wavelengths and thus the largest energies. They are due to transitions to the ground energy level from higher energy levels (E_5 to E_1 , E_4 to E_1 , E_3 to E_1 and E_2 to E_1 .) Transition E_2 to E_1 has the smallest energy difference, so this is the fourth line from the left. The next group of three lines from the left corresponds to transitions to the first excited energy level, (*i.e.*, to E_2). Thus, E_2 is involved in the formation of all three lines in the second group and in the formation of four spectral lines. The diagram with correct lines circled is shown in Figure 6-8.

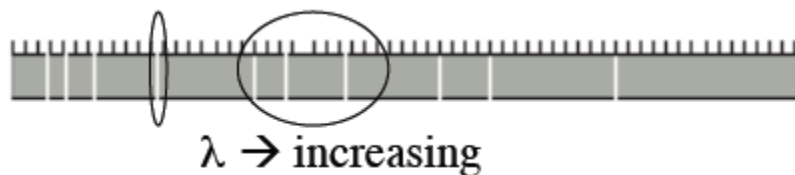
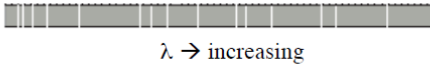

Figure 6-8 Correct response on Post-test question 2, task (ii)

Review of Post-test question 3: Students were shown a part of the line spectrum for hydrogen consisting of 15 spectral lines. They were asked to sketch the minimum number of energy levels required to produce the given spectrum. In the space designated for the energy level diagram a line representing 0 eV was drawn to probe if students recognized that the energies of the bound states are negative (i). In the second part of the question students were asked how many lines would disappear from the spectrum if the highest energy level were removed from the energy level diagram. They were also asked to circle the line(s) that would disappear from the spectrum. The wording of the tasks and the diagram presented to the students are reproduced in Figure 6-9.

[20 points total] This problem consists of two independent parts, A and B.

A. The diagram at right shows 15 lines in the discrete line spectrum for hydrogen. (λ increases to the right.)



i. [5 pts] In the space at right, sketch an energy level diagram for hydrogen that shows *only* the minimum number of energy levels required to produce the 15 lines above. Assume that only the lowest energy levels are involved in creating these 15 lines. Label the levels E_1 (for the ground state), E_2 (for the first excited state), etc. The spacing between the energy levels should be qualitatively correct. Explain briefly.

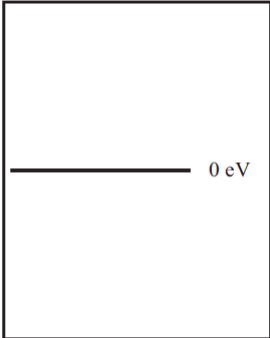

ii. Suppose you were to remove the highest energy level from your diagram.

a) [5 pts] How many lines would disappear from the spectrum? Explain briefly.

b) [5 pts] On the diagram at right, circle the line(s) that would disappear if the highest energy level were removed. Explain.

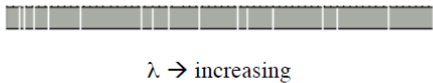

Figure 6-9 Post-test question 3

Correct response: (i) The diagram has 15 lines, which correspond to 15 transitions. If there were two energy levels, there would be 1 transition. Adding a third energy level adds 2 transitions; adding a fourth energy level adds 3 transitions; adding a fifth energy level adds 4 transitions; and adding a sixth energy level adds 5 transitions. Thus, 15 transitions require 6

energy levels. Since $E_1/E_n = n^2$, the distance between energy levels decreases with n^2 . Note: All E_n are negative.

(ii) Removing the highest energy level ($n = 6$) would remove 5 lines from the spectrum, since that energy level gives 5 possible transitions - one to each of the lower energy levels.

The first five lines on the left have the smallest wavelengths and thus the largest energies. So they are due to transitions to the ground energy level from higher energy levels (E_6 to E_1 , E_5 to E_1 , E_4 to E_1 , E_3 to E_1 and E_2 to E_1 .) Transition E_6 to E_1 has the greatest energy difference, so this is the first line on the left. The next group of four lines from the left correspond to transitions to E_2 . Transition E_6 to E_2 has the greatest energy difference in that group, so it is again the first line from the left in this group. The next group of three lines corresponds to transitions to E_3 , and the transition E_6 to E_3 is the first line from the left in that group. The next two lines correspond to transitions to E_4 , and the left line is again E_6 to E_4 . The last line is due to the transition from E_6 to E_5 (the smallest energy difference and the largest wavelength). The diagram with the correct lines circled is shown in Figure 6-10.

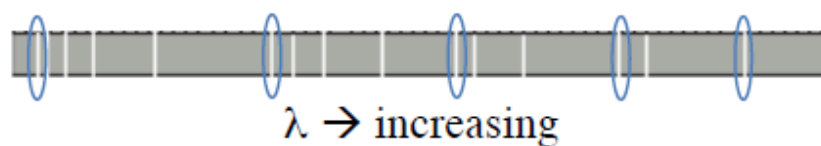

Figure 6-10 Correct answer on Posttest question 3, task (ii)

Results: After completing the tutorial, about 90% of the students sketched the correct number of energy levels (with correct reasoning) for the spectrum consisting of 10 lines and also about 90% of the students sketched the correct number of energy levels (with correct reasoning) for the spectrum consisting of 15 lines. This is again a significant improvement compared to the pretest results on the similar question. Some students (about 25%) had problems with negative energies. Percentages of correct answers from task (i) are presented in Tables 6-3 and 6-4.

Table 6-3 Results from Post-test question 2, task (i)

	UW Regular N = 177 AFTER TUTORIAL	UW Honors N = 37 AFTER TUTORIAL	UW Regular N = 177 PRETEST	UW Honors N = 37 PRETEST
Task (i) Energy level diagram consists of 5 energy levels	85 %	95 %	30 %	45 %
Problem with negative energies	25 %	15 %		

Table 6-4 Results from Post-test question 3, task (i)

	UW Regular N = 174 AFTER TUTORIAL	UW Regular N = 177 PRETEST
Task (i) Energy level diagram consists of 6 energy levels	90 %	30 %
Problem with negative energies	25 %	

Task (ii) was again more difficult for students. As table 6-5 shows, about 80% of the students recognized the correct number of lines that would disappear from the spectrum if the highest energy level were removed. In a parallel question, given to students in the other section, about 60% of the students recognized that energy level E_2 from Post-test question 2 is involved in the formation of 4 lines. The summary of the results is given in Table 6-5.

Table 6-5 Results from task (ii) from Posttest questions 2 and 3

	UW Regular N = 177 AFTER TUTORIAL	UW Regular N = 174 AFTER TUTORIAL
<i>Posttest question 2: energy level E_2 is involved in formation of 4 lines</i>	60 %	
<i>Posttest question 2: correct lines circled</i>	35 %	
<i>Posttest question 3: 5 lines would disappear from spectrum</i>		80 %
<i>Posttest question 3: correct lines circled</i>		35 %

A slightly smaller fraction of students gave the correct answer to Post-test question 2 than to Post-test question 3. One of the possible reasons is that some students forgot to count the transition from energy level E_2 to energy level E_1 (10%), and the additional 10% of the students forgot to look at transitions going to energy level E_2 . In this question students needed to take into account transitions from and to energy level E_2 , while in Post-test question 3, they only needed to look for the transitions from energy level E_6 .

6.3.1.3. Additional Post-test question

Exam questions presented in previous sub-chapters contained an additional part, which was mostly focused on tutorial homework. In some exam versions students were asked the question about the role of experimental setup in spectra formation (presented in Chapter 7), and in other versions the question about energy levels for singly ionized helium gas.

Review of post-test question on singly ionized helium: "For hydrogen, there are three energy levels with energy $E_{3, \text{hydrogen}}$ or less. For singly ionized helium gas, is the number of energy levels with energy $\leq E_{3, \text{hydrogen}}$ greater than, less than, or equal to three? Explain."

Correct response: For hydrogen, there are three energy levels (E_1 , E_2 , and E_3) with energy $\leq E_{3, \text{hydrogen}}$. Let E_1 be the ground state energy for hydrogen. Then, $E_{3, \text{hydrogen}} = E_1/9$.

Ionized helium has two protons, so the energy of the energy levels can be written as

$E_n = Z^2 E_1 / n^2$. The ground state energy for helium is thus $4E_1$, the second is E_1 , the third is $4E_1/9$, the fourth is $E_1/4$, the fifth is $4E_1/25$, the sixth is $E_1/25$, etc. Note, these are all negative; thus, there are six energy levels for helium gas with energy $\leq E_{3,hydrogen}$.

Hence, the number of energy levels with energy $\leq E_{3,hydrogen}$ for ionized helium is greater than the number of energy levels with energy $\leq E_{3,hydrogen}$ for hydrogen.

Results: This question was posed to 174 students in the regular sections at the University of Washington and to 52 students in the honors section at the same institution. The results varied from 15 % of correct answers in the regular section to 40 % in the honors section. The main problem that students had was reasoning with the negative sign, which is best illustrated with the next student response:

“It should be less since , where Z is the number of photons and equals 2, where E_0 is the ground state of hydrogen. Due to this, the helium energy states are larger, so their number with energy less than E_0 is smaller.” (UW Honors)

This student, as most of the other students, obviously forgot that the energy of the ground level of hydrogen, E_0 is negative and that the energy of the ground level of helium is thus smaller.

6.2.1.4 Post-test questions after interactive tutorial lectures

About 350 students at the University of Washington participated in interactive tutorial lectures. On the third exam, they were given two multiple-choice questions that addressed the same ideas as the free-response questions discussed above. Two sets of two multiple-choice questions were administered, each for one section. Altogether, there were four questions, to which we will refer as Question 1, 2, 3 and 4.

Review of Question 1: The students were shown a part of the line spectrum consisting of 14 spectral lines. They were asked about the minimum number of energy levels required to produce the given spectrum. The task is reproduced in Figure 6-11.

Correct response: The diagram has 14 lines, which correspond to 14 transitions. If there were two energy levels, there would be 1 transition. Adding a third energy level adds 2 transitions, adding a fourth energy level adds 3 transitions, adding a fifth energy level adds 4 transitions, which gives 10 transitions. Adding a sixth energy level adds 5 more transitions. Thus, 14 transitions require 6 energy levels and this corresponds to answer B.

The diagram below shows 14 of the lines in the line spectrum for a particular gas. (Wavelength increases to the right.) What is the minimum number of energy levels in each atom of the gas that could produce this number of lines in a spectrum?

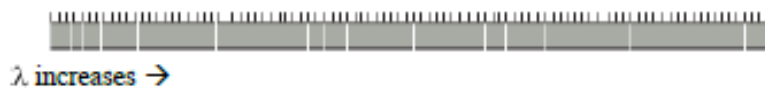

- A. 5
- B. 6
- C. 7
- D. 13
- E. 14

Figure 6-11 Posttest question 1

Results: This question was given to 130 introductory students in a regular section of the introductory physics course at the University of Washington. About 70% gave the correct response and only 10 % thought that the correct response is E, *i.e.* that each line in the spectrum corresponds to one energy level.

Review of Question 2: The same students were given another question, in which they were shown 6 spectral lines, and asked about the number of lines in the spectrum in whose formation energy level E_2 was involved. The task is reproduced in Figure 7-12. This question was similar to task (ii) in Post-test question 2.

The diagram below shows all the lines in a line spectrum that are emitted by the lowest n energy levels of a gas. (n is a number greater than 2.) Let E_1 represent the ground state and let E_2 represent the first excited state.

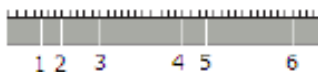

Energy level E_2 is involved in the formation of how many lines in the spectrum?

- A. 1
- B. 2
- C. 3
- D. 4
- E. more than 4

Figure 6-12 Posttest question 2

Correct response: The energy level E_2 is involved in the formation of three spectral lines. The diagram has 6 lines, which correspond to 6 transitions, and this corresponds to 4 energy levels. Energy level E_2 is involved in three transitions E_2 to E_1 , E_3 to E_2 and E_4 to E_2 .

Results: About 50% of students recognized that the energy level E_2 is involved in the formation of three spectral lines.

Question 3 and Question 4 were administered to 120 introductory students in the regular sections at the University of Washington after interactive tutorial lectures. The questions and the results are presented below.

Review of Question 3: In the third question students were shown an energy level diagram consisting of 5 energy levels. They were asked how many additional spectral lines are accounted for by the addition of these two energy levels. The whole question is presented in figure 6-13. This question was similar to task (ii) in Post-test question 1.

The diagram at right shows the 5 lowest energy levels in a particular gas. These account for some of the spectral lines for the gas. Suppose two more energy levels (E_6 and E_7) were added to the diagram.

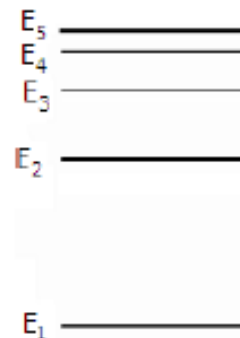

How many *additional* spectral lines are accounted for by the addition of these two energy levels?

- A. These account for 2 additional spectral lines.
- B. These account for 4 additional spectral lines.
- C. These account for 10 additional spectral lines.
- D. These account for 11 additional spectral lines.
- E. These account for more than 11 additional lines.

Figure 6-13 Posttest question 3

Correct response: The next energy level (the sixth), in conjunction with the original 5 energy levels, gives rise to 5 new lines in the spectrum (5 transitions, one to each of the other energy levels). The seventh energy level, in conjunction with six other levels, gives rise to 6 new lines in the spectrum (6 transitions, one to each of the other energy levels). Thus, these two levels account for 11 additional spectral lines.

Results: About 65% of the students answered Question 3 correctly.

Review of Question 4: In the last multiple-choice question students were asked about the greatest photon energy. This question probed the ability of students to think about transitions, and not just the energies. Question 4 is given in Figure 6-14.

Suppose you know the energies of all the energy levels for a particular gas ($E_0, E_1, E_2, \text{etc.}$) In the line spectrum for this gas, no photon has energy greater than:

- A. $|E_0|$
- B. $|E_1 - E_0|$
- C. 0
- D. The absolute value of the energy of the highest energy value
- E. There is no limit to the energy of the photons in the line spectrum

Figure 6-14 Posttest question 4

Correct response: The greatest photon energy corresponds to the greatest transition, and this is the transition from the unbound state (with energy 0 eV) to the ground energy level

with energy E_0 , where E_0 has a negative value. For that case, the photon energy equals $|E_0|$ and this is the greatest photon energy.

Results: About 35% of the students recognized that $|E_0|$ is the greatest photon energy in the line spectrum.

6.2.2 DISCUSSION OF THE POST-TEST RESULTS

As can be noted from the results presented, student performance after research-based instruction was considerably higher than after standard lectures. The post-test results were slightly better after the tutorial than after the tutorial lecture. Posttest results for students that completed tutorials were also higher than the results obtained from junior students who had completed all the introductory physics courses, optics labs and modern physics courses including a quantum mechanics course.

Task (i) in all three free-response post-test questions probed the same issue just in a slightly different context. Question 1 from the multiple choice series of questions also addressed the same issue. That question probed if students recognized that spectral lines are formed as a result of transitions between energy levels. The results from all groups of students, together with the pretest results from the similar questions, are summarized in Table 6-6. These results suggest that students made a significant improvement after tutorial instruction.

Table 6-6 Summary of correct answers on task (i) given in various forms and to various groups of students together with pretest results

	UW Honors N = 52 AFTER TUTORIAL	CRO Intro N = 100 AFTER TUTORIAL	UW Regular N = 177 AFTER TUTORIAL	UW Honors N = 37 AFTER TUTORIAL	UW Regular N = 174 AFTER TUTORIAL	UW Regular N = 174 AFTER TUTORIAL LECTURE	ALL INTRO STUDENTS N = 700 PRETEST	Cro Juniors
Question asked:	Posttest question 1	Posttest question 1	Posttest question 2	Posttest question 2	Posttest question 3	Question 1	Pretest	Pretest
Percentage of correct answers	95 %	85 %	90 %	95 %	85 %	70 %	30 %	50 %

Task (ii) in all free response questions also probed the same issue – the extent to which students developed a functional understanding of transitions and the formation of lines in a spectrum. This task probed the same idea, but in a slightly different context from that used in the pretest and the tutorial. In addition, students were asked to identify which line corresponded to which transition. In Questions 2 and 3 in the multiple-choice questions that were given after the tutorial lecture, students were also asked to do the same. Results from all questions are summarized in Table 6-7.

Table 6-7 Summary of correct answers on task (ii) given in various forms and to various groups of students

	UW Honors N = 52 AFTER TUTORIAL	CRO Intro N = 100 AFTER TUTORIAL	UW Regular N = 177 AFTER TUTORIAL	UW Honors N = 37 AFTER TUTORIAL	UW Regular N = 174 AFTER TUTORIAL	UW Regular N = 130 AFTER TUTORIAL LECTURE	UW Regular N = 120 AFTER TUTORIAL LECTURE
Question asked:	Posttest question 1	Posttest question 1	Posttest question 2	Posttest question 2	Posttest question 3	Question 2	Question 3
Percentage of correct answers	90 %	65 %	60 %	90 %	80 %	65 %	50 %

7. ADDRESSING STUDENT DIFFICULTIES WITH BASIC SPECTROSCOPIC EXPERIMENTS

Results from our investigations of student understanding of spectra have been used to develop instructional materials for introductory physics courses that are designed to address student difficulties with basic spectroscopic experiments. Section 7.1 describes relevant parts of this tutorial. The results from post-test are summarized.

7.1. SPECTRA TUTORIAL- OPTICAL SYSTEMS

7.2.1. REVIEW OF STUDENT DIFFICULTIES

As has been described in Chapter 4, students often did not associate line spectra with a particular type of source. This error includes several types of mistakes: failure to distinguish between diffraction patterns and a line spectrum, the belief that a prism always gives a continuous spectrum, the belief that a monochromatic source gives a discrete spectrum and the belief that a prism only makes the spectrum wider. Instructional strategies were designed to address these difficulties.

7.2.2. DESCRIPTION OF INSTRUCTIONAL STRATEGIES

In its most recent version, the tutorial on atomic spectra optical systems consists of two main parts. In the first part a student dialogue is presented in which students discuss the possible changes to the optical system that could lead from a continuous to a discrete spectrum (Figure 7-1).

A. The experimental setup shown below consists of a light source (an incandescent light bulb), a single slit with adjustable width, a glass prism and a screen. The screen is located far from the prism. When the bulb is lit, a continuous spectrum of wavelengths appears on the screen.



Three students are discussing what they need to do in order to get line spectra shown on the picture below:



Line spectrum students want to observe

Student 1: *"We need to change the width of the slit. When we change the width of the slit, we change the width of the lines. I would make slit narrower. The picture will become sharper and the lines will separate from one another."*

Student 2: *"Even if we change the width of the slit the light will fall on the prism and the prism will always refract the light in such a way that we get continuous spectrum. I would replace the prism with the diffraction grating which is a better optical instrument and helps us to see lines separated."*

Student 3: *"I would replace the light bulb with a different type of source. We need the monochromatic source of light."*

With which students, if any, do you agree? Explain your reasoning.

Figure 7-1 The first part of the tutorial – the student dialog

The goal of this part of the tutorial is to focus attention on the experimental set-up and to initiate discussions among the students. They can proceed to the second part of the tutorial even if they have not found the correct answers because the tutorial brings students back to that discussion at the end of the worksheet. At that point, the students need to reflect on their previous answers and resolve any inconsistencies.

The second page of the current version of this tutorial (Appendix A – 5 and A - 6) guides students through different experiments with different light sources, slit, prism, and optical

grating. Students predict what they would observe on the screen in different experimental set-ups. The first set of predictions includes questions with green and white light and involves different slit widths. After the students have made their predictions and explained their reasoning, they are shown a handout (Appendix A – 8) with photographs that illustrate the patterns that appear on a distant screen. Students are asked to make a second set of predictions is also based on a green and white light source. However, this time a prism or a diffraction grating are also included. A diagram of light incident on a 2 mm wide slit is shown to the students. They are asked to predict what would appear on the screen if a prism or a diffraction grating were inserted between the slit and the screen. Again, after students have made their predictions and explained their reasoning, handouts with photographs that illustrate the patterns are shown. Students are then asked to refer again to the discussion among the three students in the first part of the tutorial, and to check if they agree with their previous answer. The main goal of this tutorial is to remind students of diffraction on the single slit both for monochromatic and for white light. We hoped that they would recognize that the diffraction patterns of white light produced by a single slit or grating would be complicated by the fact that the incoming light contained a range of wavelengths, but that the spectrum would still be continuous and not discrete as most of the students seemed to think.

After completing this part of the tutorial, students are expected to differentiate conditions under which continuous and discrete spectra are formed. More precisely, they should recognize the difference between a diffraction pattern and a discrete spectrum and to recognize the role of the different parts of the experimental set-up (the slit, the prism and the optical grating) in formation of the spectrum. This version of the tutorial was used in introductory physics courses at the University of Zagreb.

There was not enough time for the same version of the spectra tutorial on optical systems to be used at the University of Washington. Therefore, a tutorial homework assignment was designed for the purpose of completing the shorter version of the tutorial. Two different versions of homework were developed. In each, the experimental set-up constituted just one part of the homework. The other part focused on energy levels and transitions. Both versions of the homework are presented in the Appendix. Only the part dealing with the experimental set-up is described here.

In the first version of the homework, an experimental set-up consisting of a hydrogen lamp, a slit, a prism, and a screen were presented. The students were asked how different changes in the experimental setup would affect the appearance on the screen (Figure 7-2). This question tried to introduce the role of the prism in the formation of a spectrum. Furthermore, the question was intended to remind students of the refraction of light by a prism and of the diffraction of light by a narrow slit. The goal of the homework was to help students recognize the difference between a diffraction pattern and a discrete spectrum. Unfortunately, after analyzing the posttest data that are presented in the next paragraph, we found that the homework was not successful in addressing the problems that students had in understanding the role of the experimental set-up. Some changes have been made.

The line spectrum in question 1 was obtained by placing a mask that has a wide slit (~1 mm) and a prism between a screen and a hydrogen lamp. (See figure at right.)

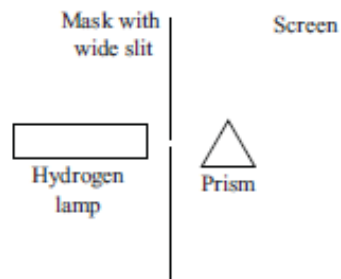

a. Predict what you would see on the screen if the prism were removed, as shown at right. Explain briefly.

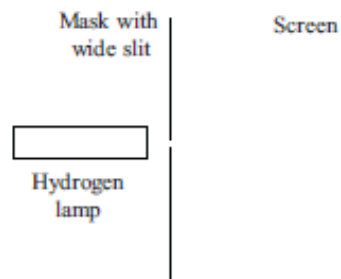

b. Predict what you would see on the screen if the prism were put back in place and the hydrogen lamp were replaced by a green light source, as shown. Explain briefly.

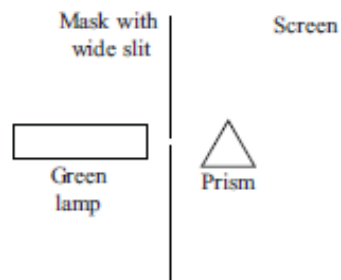

c. Predict what you would see on the screen if the prism were now removed and replaced by a mask with a narrow slit (~1 μm wide).

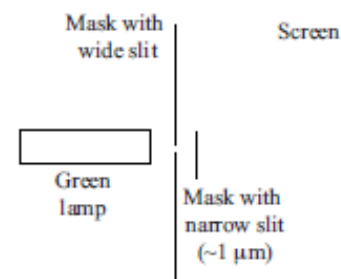

Figure 7-2 A problem from a homework assignment

The second version of the homework also consisted of one problem addressing the role of the experimental setup. On the first page, the 12 different experimental setups are shown (Figure 6-3). The second page consists of 12 different patterns observed on the screen (Figure 6-4). Students were asked to indicate which of the experimental setups would result in each pattern on the screen. The role of this problem was to remind students of the conditions under which a diffraction pattern is observed, to help them recognize the

difference between the pattern produced by a wide and by a narrow slit, by a prism and an optical grating, and by different types of light sources. In this tutorial homework two monochromatic sources of light are introduced in order to remind students that different colors of light are refracted at different angles by the prism, and that their diffraction patterns also differ, more precisely, that diffraction minima occur at different angles.

2. The table below consists of 12 different experimental setups (A – L). There are four different sources of light (one for each row) and three different setups: a wide slit (1 mm wide) without a prism, a wide slit with a prism, and a narrow slit (1 μm wide) without a prism.

	Mask with wide slit (no prism)	Mask with wide slit and prism	Mask with narrow slit (no prism)
Green lamp	<p>Mask with wide slit Green lamp Screen A</p>	<p>Mask with wide slit Green lamp Prism Screen B</p>	<p>Green lamp Mask with Narrow slit (~ 1 μm) Screen C</p>
Red lamp	<p>Mask with wide slit Red lamp Screen D</p>	<p>Mask with wide slit Red lamp Prism Screen E</p>	<p>Red lamp Mask with Narrow slit (~ 1 μm) Screen F</p>
Incandescent lamp	<p>Mask with wide slit Incandescent lamp Screen G</p>	<p>Mask with wide slit Incandescent lamp Prism Screen H</p>	<p>Incandescent lamp Mask with Narrow slit (~ 1 μm) Screen I</p>
Hydrogen lamp	<p>Mask with wide slit Hydrogen lamp Screen J</p>	<p>Mask with wide slit Hydrogen lamp Prism Screen K</p>	<p>Hydrogen lamp Mask with Narrow slit (~ 1 μm) Screen L</p>

Note:: Assume for this problem that light from both the hydrogen and incandescent lamps appears white when viewed directly by eye.

Figure 7-3 The homework assignment

We were hoping that the homework assignment would help students understand the diffraction of white light by a single slit and recognize the difference between a diffraction pattern and a discrete spectrum.

2. (continued) The figure below shows the 12 patterns that would be observed on the screens in cases A-L. The center of each screen is in the center of each pattern. (Note: Patterns 2 and 6 appear identical.) Below each pattern, indicate which of the experimental setups would result in that pattern. Explain briefly. (Hint: Each pattern corresponds to one and only one experimental setup.)













<p>Pattern 1: (green)</p>  <p>Experimental setup: _____ Briefly explain.</p>	<p>Pattern 2: (white)</p>  <p>Experimental setup: _____ Briefly explain.</p>	<p>Pattern 3: (colored lines)</p>  <p>Experimental setup: _____ Briefly explain.</p>
<p>Pattern 4: (red)</p>  <p>Experimental setup: _____ Briefly explain.</p>	<p>Pattern 5: (green)</p>  <p>Experimental setup: _____ Briefly explain.</p>	<p>Pattern 6: (white)</p>  <p>Experimental setup: _____ Briefly explain.</p>
<p>Pattern 7: (green)</p>  <p>Experimental setup: _____ Briefly explain.</p>	<p>Pattern 8: (red)</p>  <p>Experimental setup: _____ Briefly explain.</p>	<p>Pattern 9: (multi-colored)</p>  <p>Experimental setup: _____ Briefly explain.</p>
<p>Pattern 10: (multi-colored)</p>  <p>Experimental setup: _____ Briefly explain.</p>	<p>Pattern 11: (red)</p>  <p>Experimental setup: _____ Briefly explain.</p>	<p>Pattern 12: (multi-colored)</p>  <p>Experimental setup: _____ Briefly explain.</p>

Figure 7-4 Homework assignment, continued

This version of the homework was given to 350 students at the University of Washington, but unfortunately it was the last homework in the tutorial sequence and not graded. Therefore, it was impossible to estimate how many students solved the problems. The results from a post-test question given to 177 students are discussed in the next section.

7.2. ASSESSMENT OF INSTRUCTIONAL STRATEGIES

In order to assess the effectiveness of the curriculum, we administered one posttest question. This question was given as an exam question to students at University of Zagreb, who had completed the tutorial on experimental setups and to different groups of students at University of Washington. The task was designed to probe the extent to which students have improved their understanding of the role of the experimental setup in the formation of a discrete spectrum.

The exam question describes an experimental setup that contains a prism. The continuous spectrum that results is similar to the one shown in the tutorial and the tutorial homework. The exam question is shown in Figure 7-5. Students were asked what they would expect to see on the screen if the prism were replaced by a diffraction grating.

B. The experimental setup shown at right consists of an incandescent light bulb, a mask containing a single slit, a glass prism, and a screen. The screen is far from the prism. When the bulb is lit, a continuous spectrum of wavelengths appears on the screen.

Suppose the prism were replaced by a diffraction grating. (Everything else remains the same.) Which of the following would you expect to see on the screen?

- A. The picture on the screen would stay the same.
- B. There would be one white line in the middle of the screen and a line spectrum to the left and to the right of that line.
- C. There would be white maxima and black minima on the screen.
- D. There would be a bright spot that spans the entire screen.
- E. None of the above.

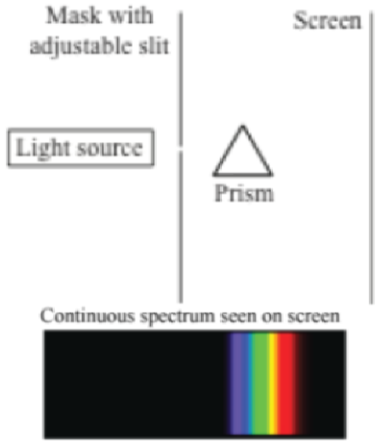

Mask with adjustable slit

Light source

Prism

Screen

Continuous spectrum seen on screen

Figure 7-5 The exam question

Students were expected to recognize that if the source of the light remained the same, the continuous spectrum would remain on the screen, but due to the optical grating, more patterns would be visible, with a white maximum in the middle of the screen. Students were expected to recognize that the diffraction patterns produced by a single slit would be complicated by the fact that the incoming light consisted of a range of wavelengths. This answer was not offered to the students, and thus “none of the above” is the correct answer. This question probed the ability of students to distinguish between a discrete spectrum and a diffraction pattern, and also to recognize the role of the optical grating in the experimental setup.

This exam question was given to 50 introductory students at the University of Zagreb, to 89 students in honors sections at the University of Washington and to 350 students in regular sections at the University of Washington. 270 students were given the multiple-choice version of the question and another 220 students were also asked for an explanation. Results are presented in table 7-1.

Table 7-1 Results of exam question after students completed tutorial or tutorial homework

	UW 123 Regular (2010) N = 170	UW123 Regular (2011) N = 180	UW 123 HONORS N = 90	CRO INTRO N = 50
	NO Tutorial, HW1	NO Tutorial, HW2	NO Tutorial, HW1	TUTORIAL, NO HW
Discrete spectrum would appear on the screen		25%	40%	
Black and white diffraction pattern would appear on the screen		25%	30%	
CORRECT: none of the above	8%	20%	5%	50%

In 2010 170 UW regular students as well as 90 honor students, completed the atomic spectra tutorial on energy levels and transitions and the first version of the homework. 180 students from the regular section in 2011 completed the atomic spectra tutorial on energy levels and transitions and the second version of the homework, and 50 introductory students from the University of Zagreb completed the tutorial on atomic spectra and optical systems.

As table 7-1 shows, the percentage of correct answers on the exam question varies between 5% for students who completed the old version of the homework, 20% for those who completed the new version of the homework, and 50% for students who completed the tutorial on optical systems. The results on the similar pretest question varied between 5% and 30%, which means that there was no improvement after completing just the tutorial homework. The only improvement noticed was with 50 Croatian introductory students, whose results rose from 30% on the pretest to 50% on the posttest after completing the tutorial.

Students' explanations provided a deeper insight to the difficulties remaining after completing the tutorial homework. Results indicate that most of the students still struggled with the distinction between a discrete spectrum and a diffraction pattern. The following student explanations demonstrate this difficulty:

"In a sense, the diffraction grating acts like a prism, only because it is a diffraction grating, the discrete line spectrum (containing the colors of the rainbow) will be on either side of the white central maxima. The diffraction grating causes the incandescent light to strike on the screen at different phase difference, which is the reason why the different colors are produced." (UW Intro)

This student most probably does not understand the meaning of the word discrete and confuses discrete spectrum and diffraction. This student talks about colors of the rainbow. He/she probably understands that a continuous spectrum will be seen on the screen, but talks about a discrete spectrum. In the next student response this problem is even more pronounced:

"It will keep the discrete line spectrum, but with the grating instead of a prism, the central maxima would be on the middle of the screen." (UW Intro)

This student said *"it will keep the discrete line spectrum"* although the question said *"when the bulb is lit a continuous spectrum of wavelengths appears on the screen"*. He/she

recognized that if the prism were replaced with an optical grating, the same type of spectrum would appear on the screen, but stated that this spectrum is discrete. This indicated that the student does not understand the meaning of the word discrete.

The other group of students seemed to believe that a discrete spectrum would appear on the screen if the prism were replaced with an optical grating. The next student's response demonstrates this difficulty:

"The prism separates the white light of the incandescent lamp into its color components, making a "rainbow" on the screen. Without the prism this phenomenon would not occur. By adding the grating, interference is created. Thus, a discrete (non-continuous) pattern is created. A and D must be wrong. I think C is too far too simplistic to be correct. I think B accurately describes the interference patterns we have studied." (UW Intro)

This student talks about interference pattern and associates it with discrete (non-continuous) pattern. Other student explanations contain the similar mistake. Some were explicit in their reasoning; for others this error was implied.

"Using prism allows us to disperse the light causing a continuous spectrum. If we were to place a diffraction grating in the place of the prism, we would have one white line to represent the central maxima and discrete line spectrums to the left and right of it, because the light wouldn't be dispersed anymore as it was when we were using a prism." (UW Intro)

"The prism bends the light thus causing it to appear on the left side of the screen. When the prism is replaced with a diffraction grating there is no long a means to bend the light so it will have a white center in the middle of the screen. Diffraction from the mask will cause the spectrum and the grating will cause it to be discrete line spectrum as some of lines will be allowed." (UW Intro)

"Diffraction grating will cause the white light to diffract... Pattern of the white light diffraction is the same as B."

The last student response stresses once more the student difficulty already discussed – the confusion between a diffraction pattern and a discrete spectrum. Unfortunately, the tutorial homework did not properly address this difficulty.

The following students do not only have the problem understanding discrete spectra, but also understanding diffraction of white light:

“The incandescent light has all kinds of λ of light and when it passes through the diffraction grating the different λ will be “separated” due to the different positions of max/min given by $d\sin\theta=m\lambda$ ” (UW Intro)

“The diffraction grating acts like a small slit and will cause an interference pattern on the screen. Since it is white light being passed through, the spectrum will be formed on either side because the different wavelengths of the visible spectrum will be separated during the interference because they have different wavelengths so the maxima of each color will be at different position.” (UW Intro)

The third group of the students obviously did not understand the diffraction of the white light on the optical grating. They believed that diffraction pattern consisting of black and white lines is formed on the screen. This implies that they did not understand the role of optical grating properly, or that they seemed to be thinking of the pattern that would result from light of a single wavelength:

“With a grating rather than a prism, no colors would appear on the screen. The prism has a different index of refraction, so different wavelengths of light (different colors) have different angles of refraction, which is why colors are separated. With a grating, there is no change in index of refraction, but the grating pattern still appears on the screen. However, a single slit does separate the colors, but this is different than a grating.” (UW Intro)

“There would just be a diffraction grating pattern with white light because all the light is going the same speed. It doesn’t have a prism to slow/spread out the different wavelengths.” (UW Intro)

“This is because a diffraction grating creates patterns of interference and it does not separate light of different wavelengths like a prism does.” (UW Intro)

Students who completed the tutorial on the role of the experimental setup in formation of the spectrum did significantly better than students who completed just the homework, but they still struggled with discrete spectrum versus diffraction pattern and with diffraction of white light on optical grating. 50 % of student still struggled with the role of the prism and diffraction grating in the formation of the spectrum.

The results have the implication for further development of tutorial and tutorial homework. The questions what the word discrete means and why something is discrete need to be discussed more. It is important that students develop the functional understanding that line in spectrum is formed by electron transition between energy levels, but students should also be able to understand the process of the formation of the spectrum they observed. Even more concerning is the fact that students who think that a discrete spectrum is formed when the prism is replaced by the optical grating miss the main point and still do not recognize that the source of light plays the key role in the type of spectrum that is observed.

The results presented in this chapter demonstrate a need for improved instructional materials. There is also a need to create laboratory-based, instructional materials on spectroscopy for prospective and practicing precollege teachers with a focus on how the spectra are formed.

8. CONCLUSION

A major goal of the research described in this dissertation was to probe the extent to which students understand the relationship between atomic spectra and energy levels. A particular focus was on the ability of students to recognize the conditions under which discrete spectra are and are not formed and to relate the wavelengths of spectral lines to the transitions of electrons between the energy levels in an atom.

We found that many students do not develop a functional understanding of atomic spectra through standard lecture – based instruction. Some serious conceptual and reasoning difficulties persisted even after lectures on the topic. Many students did not understand how line spectra are produced and did not associate them with only certain types of sources. Some seemed to believe that line spectra are the result of light passing through optical instruments.

During the investigation, it became clear that students often had an incomplete or incorrect understanding of how energy levels and transitions of electrons between them are related to discrete line spectra. During the interviews, about half of the students did not even mention energy levels when discussing discrete line spectra. When asked about the connection between energy levels and spectral lines, many did not recognize that each spectral line is a result of a transition of an electron between two energy levels. Often they associated each spectral line with one energy level. Some students who recognized that each spectral line is associated with two different energy levels did not have a correct model for the emission of light. Many students failed to consider the ground energy level as an energy level or thought that all transitions involve the ground energy level. Similar difficulties were observed at the University of Zagreb and the University of Washington. Moreover, the errors were not confined to the introductory level but persisted throughout instruction in upper division courses and laboratories.

It might be expected that students who had completed a course on quantum mechanics or a junior-level laboratory on optics would have no problem in associating spectral lines with transitions between energy levels. However, the tasks used in this study were challenging even for those students. The results of the investigation demonstrate a need for

instructional materials: (1) that address the specific difficulties identified in our research and (2) that can help students connect the formalism taught in their courses with their observations of spectra in the laboratory.

We designed a tutorial to help address the conceptual and reasoning difficulties that were identified in our research. In order to assess the effectiveness of the curriculum, we administered post-tests that ask students to apply the concepts and ideas that they have studied in situations that are different from those in which the concepts were introduced. We found that students made significant improvement in understanding atomic transitions after working through the atomic spectra tutorial. However, problems with the role of optical systems that are used to observe spectra persisted. That portion of the curriculum still needs further development.

SUPPLEMENTARY RESEARCH

OVERVIEW

Chapter One: Introduction to the Supplement.

Chapter Two describes different types of light sources that are used while demonstrating simple spectra experiments, as well as laboratory research.

Chapter Three describes the mechanisms of broadening spectral lines. The pressure broadening is described in more detail. This chapter also describes the principles for the determination of the density of mercury atoms and of the temperature of the discharge

Chapter Four describes the characteristics of high-pressure metal halide dischargers, with particular focus on discharge containing mercury and indium atoms.

Chapter Five describes the experimental set-up. The emphasis is on the determination of the instrumental function of the monochromator. Results for the atomic density of mercury particles and temperature of discharge are given,

Chapter Six presents the discussion of the results.

1. INTRODUCTION

Spectroscopic methods are frequently used to investigate the properties of elements, compounds and ionized gases. This supplement to the dissertation describes the application of spectroscopic techniques to determine the parameters of a high pressure indium mercury gas discharge.

The advantage of spectroscopic techniques over other methods of investigation is that they make it possible to analyze the light emitted without interfering with the source.

Investigation of the width and shift of atomic spectral lines emitted from the plasma gives the information about basic plasma parameters such as temperature, pressure and concentration of the particles. Also, the shape of lines provides the information about interactions between particles in the discharge. In this research parameters of investigated plasmas are determined by measuring absolute lateral intensities (radiance) of optically thin mercury lines. Lateral intensities are transformed in localized radial emission coefficients. Line intensities of high pressure gas discharge are compared with radiation of calibrated low pressure mercury discharge (radiometric standard) with known irradiances of 14 most prominent lines in visible and near infra-red. Mercury atom density is determined using resonant line broadening of two lines in visible and near infra-red spectrum.

2. LIGHT SOURCES

When the light is passed through a dispersing element to produce a spectrum, the type of spectrum seen depends on what kind of object is producing a light, i.e. on the type of light source. Light sources may be divided into broad-band or continuum sources and narrow-band or line sources.

2.1. SOURCES OF CONTINUOUS SPECTRA

2.1.1 INCANDESCENT LAMP

Most continuous spectra are formed from hot dense objects (stars, plasma discharge, incandescent lamp, etc.). Any solid, liquid and dense gas at a temperature above absolute zero will produce a thermal spectrum that is also called a blackbody spectrum. Hot, dense objects will emit electromagnetic radiation at all wavelengths or colors. A widely used example of a source of a continuous spectrum is an incandescent lamp (Fig. 2-1.). It is used for class demonstrations of a continuous spectrum and it is still frequently used in households.

For class demonstration purposes, the tungsten lamp filament can be regarded as an almost black body radiator.

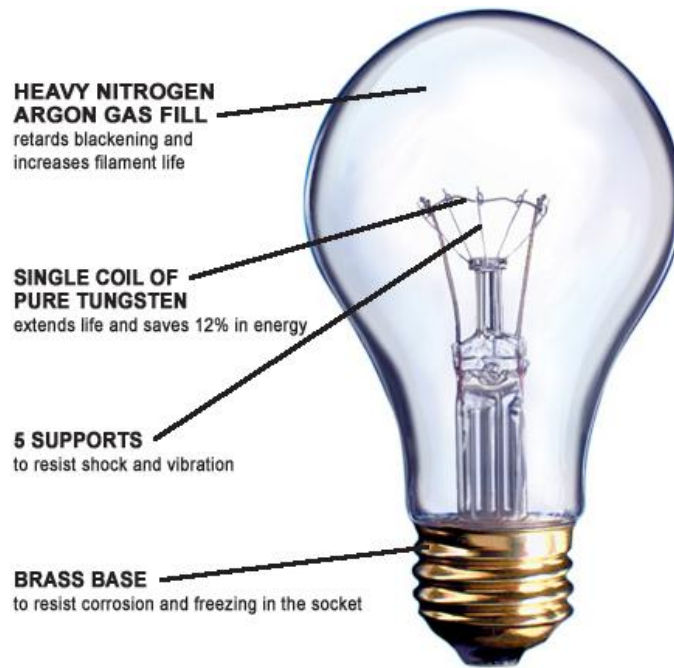

Figure 2-1 An example of incandescent lamp. Picture taken from: http://www.superiorlampinc.com/product_line/incandescent.htm

2.1.2. BLACK BODY

A black body is an idealized physical body that absorbs all incident electromagnetic radiation and reflects none of it, hence, it appears black. The black body is a perfect absorber and therefore also a perfect emitter. The experimental construction consists of a small hole in the side of a large box that is thermally isolated from the surroundings. Such a box is an excellent absorber, since all radiation that goes through the hole bounces around inside. A lot is getting absorbed on each bounce, and has little chance of ever getting out. And also reversed: the radiation coming out of the hole is a good representation of a perfect emitter.

For a solid or a gas in thermodynamic equilibrium, the density of the radiation between λ and $\lambda+\Delta\lambda$ is given by Planck' formula:

$$\rho(\lambda, T)d\lambda = \frac{8\pi hc}{\lambda^5} \cdot \frac{1}{e^{\frac{hc}{\lambda kT}} - 1} d\lambda \text{ [Jm}^{-3}\text{]}, \quad (2-1)$$

where $\rho(\lambda, T)$ is the energy density per unit wavelength interval. Expressed in terms of frequency this formula becomes:

$$\rho(\nu, T)d\nu = \frac{8\pi h\nu^3}{c^3} \cdot \frac{1}{e^{\frac{h\nu}{kT}} - 1} d\nu \text{ [Jm}^{-3}\text{]}. \quad (2-2)$$

The flux of radiation in the waveband $d\lambda$ escaping from a small hole of unit area into unit solid angle defines the luminance or brightness of a black body source:

$$B_0(\lambda, T)d\lambda = \frac{\rho(\lambda, T)c}{4\pi} d\lambda = \frac{2hc^2}{\lambda^5} \cdot \frac{1}{e^{\frac{hc}{\lambda kT}} - 1} d\lambda \text{ [Wm}^{-2}\text{sr]}. \quad (2-3)$$

Expressed as a function of frequency it is:

$$B_0(\nu, T)d\nu = \frac{2h\nu^3}{c^2} \cdot \frac{1}{e^{\frac{h\nu}{kT}} - 1} d\nu \text{ [Wm}^{-2}\text{sr]}. \quad (2-4)$$

Figure 2-2 shows the Planck distribution (Equation 2-1) as a function of wavelength for different temperatures. It is noticeable that for increasing temperature the absolute value of energy density increases and the maximum of the distribution move towards shorter wavelengths.

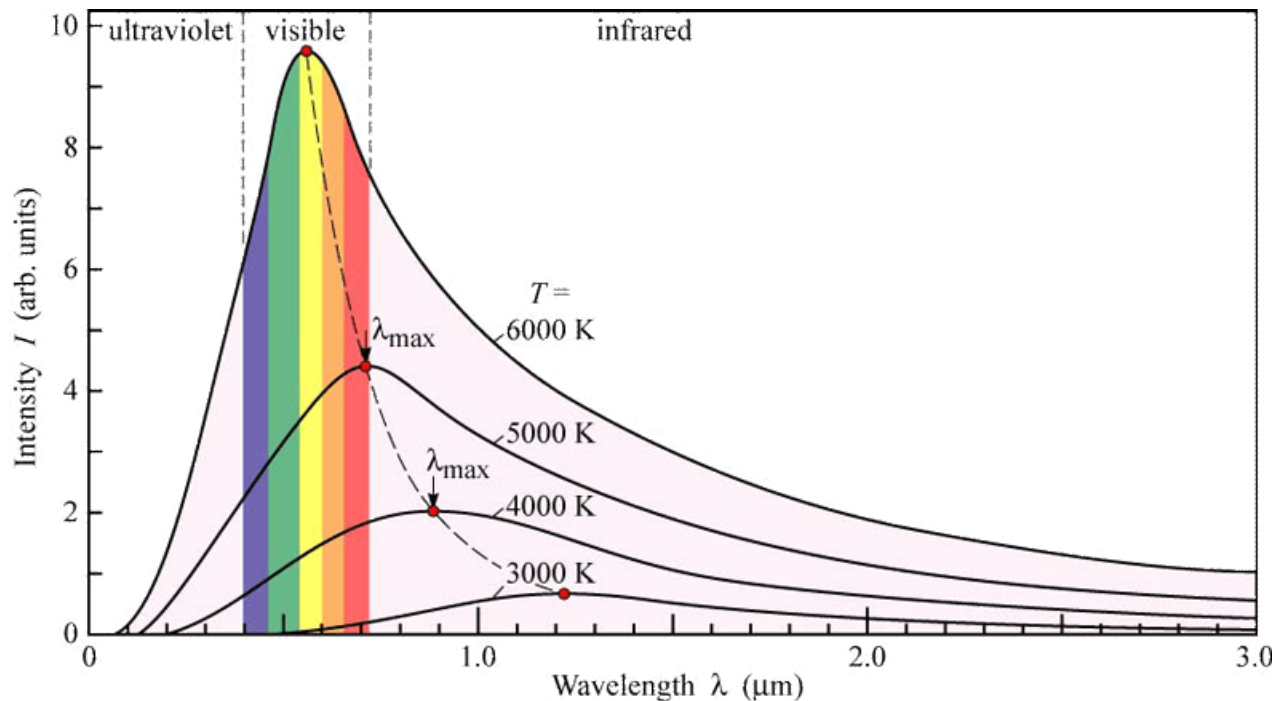

Figure 2-2 Spectral intensity distribution of Planck's black-body radiation as function of wavelength for different temperatures. Picture taken from: https://www.phy.questru.ca/rknop/classes/enma/2010-10/wiki/index.php/Blackbody_Radiation

Wien showed that the product of the wavelength at maximum of energy density function and the temperature is constant:

$$\lambda_m T = 2,884 \cdot 10^{-3} \text{ [m}\cdot\text{K]}. \quad (2-5)$$

Since the blackbody is a source of radiation with maximal brightness at any wavelength, the brightness of any other body can be expressed as:

$$B(\lambda, T) = \epsilon_\lambda B_0(\lambda, T), \quad (2-6)$$

Where ϵ_λ shows how a real body compares to black body and is called emissivity. It is the ratio of the radiant power emitted per area to the radiant power emitted by black body per area and thus $\epsilon_\lambda < 1$. The emissivity ϵ_λ is the function of wavelength, but if it is almost constant the source is known as a grey body. Tungsten ribbon (strip) is usually very nearly grey body and this makes it the most useful radiation standard in spectroscopy.

RADIATION STANDARDS

A primary radiation standard is a source for which the radiated power is known theoretically as a function of wavelength. The only practical such source is black body enclosure. It can be seen from Figure 2-2 that a black body is a feasible laboratory standard in the infra-red and visible, but the sharp drop of intensity on the short wavelengths make it inconvenient for the violet and ultraviolet regions. In the regions with wavelength smaller than 300 nm deuterium lamp is used as radiation standard.

Secondary standards, which must be calibrated against the primary standard, are therefore essential. The most useful secondary standards are the tungsten and tungsten-halogen strip lamps.

2.2. SOURCES OF LINE SPECTRA

Most important types of traditional light sources for classroom demonstration are flames and spectral lamps.

2.2.1. FLAMES

Most flames have temperature of the order of 2000 K. Because of low excitation energy the strongest atomic lines excited are the resonance⁶ lines. The main field of use of flame is in the study of the molecules and radicals formed in the combustion process and in atomic absorption spectroscopy as well as in spectrochemical analysis. Flames are also used as demonstration tool in classroom for introducing the line spectra and showing that different elements have different and unique line spectrum.

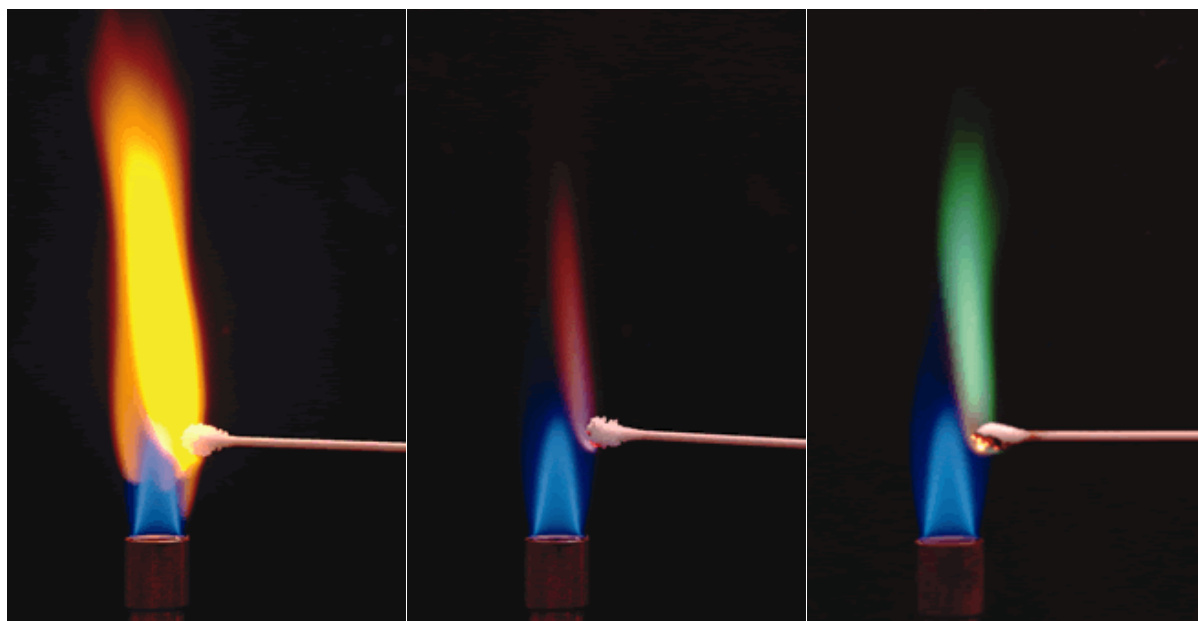

Figure 2-3 Flame test for Sodium (from NaCl), Potassium (From KCl) and boric acid (H_3BO_3 contained in eye wash) Picture taken from Journal of Chemical Education – Classroom activity - Sanger, Michael J. *J. Chem. Educ.* 2004 81 1776A.

⁶ Resonance line is a spectral line caused by an electron jumping between the first excited and the ground state in an atom or ion. It is the longest-wavelength line produced by a jump to the ground state

2.2.2. SPECTRAL LAMPS

A gas spectral lamp (gas discharge lamp) is a light source that generates light by creating an electrical discharge through an ionized gas. Typically, these lamps use noble gases such as argon, neon, krypton and xenon, or a mixture of these gasses. Many lamps are also filled with alkali or mercury, while some others have metal halide additives.

When power is applied to the lamp, an electrical field is generated between tips of electrodes. This field accelerates primary free electrons in the gas. The electrons collide with the gas and metal atoms producing excited atoms and ionized atoms, as well as new secondary electrons. When the electron of the excited atom returns to its previous energy state, it releases energy in the form of light. This light can be anything between IR, visible or UV radiation. There are many different types of gas discharge lamps. These types of lamps, especially mercury lamps, are used for class demonstration of line spectrum.

Commonly, we separate them in two basic categories: low pressure discharge lamps and high pressure discharge lamps.

LOW PRESSURE DISCHARGE LAMPS

Low-pressure discharge lamps have working pressure much less than atmospheric pressure. For example, common fluorescent lamps operate at a pressure of about 3 mbar. They all have very good efficiency. Sodium low pressure lamps, which are still used for street lighting, are the most efficient among all gas discharge lamps. The mercury pencil lamp used in this research as a standard of radiation belongs to this group of sources (Fig. 2-4).



Figure 2-4 Low- pressure mercury pencil lamp with Power Supply <http://www.newport.com/Pencil-Style-Calibration-Lamps>

HIGH PRESSURE DISCHARGE LAMPS

High-pressure discharge lamps have a discharge that takes place in gas or metal vapors at atmospheric or even higher pressures.

Typical examples are so called “high-intensity discharge lamps” (HID lamps), a type of electric discharge which produces light by means of an electric arc between tungsten electrodes housed inside a translucent (fused alumina) or transparent (fused quartz) arc tube (Figure). This tube is filled with both gas and metal salts. The gas facilitates the arc's initial strike. Once the arc is started, it heats and evaporates the metal salts, forming plasma, which greatly increases the intensity of light produced by the arc and reduces its power consumption.

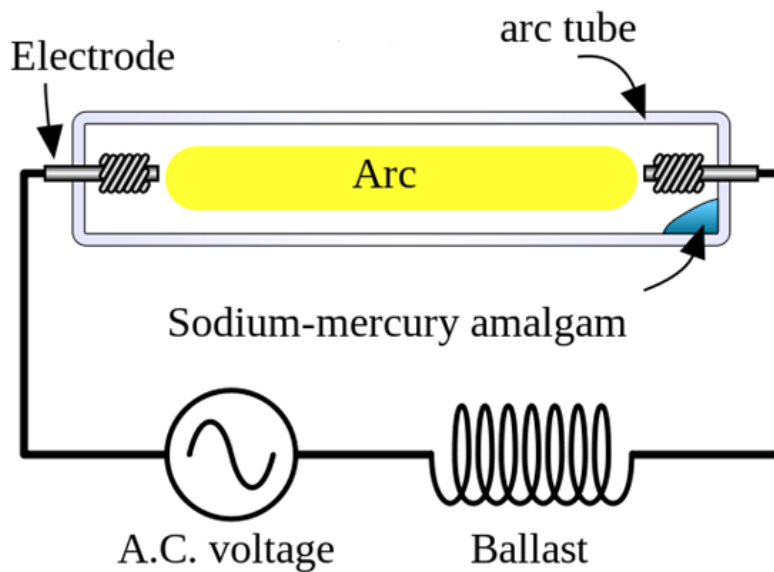

Figure 2-5 The diagram of a high pressure lamp with its source of current. Picture taken from: http://en.wikipedia.org/wiki/High-intensity_discharge_lamp

Metal halide gas discharge lamps are increasingly being used in all kinds of application areas such as accent lighting in shops, indoor and outdoor sports, studio, theater, and disco lighting, motor car head lights, and for projection purposes.

2.2.3. RADIATION

The intensity of radiation of frequency ν_{12} emitted by an atom in flame or electrical discharge, as a result of radiative transition between two discrete states (2) and (1) is determined by the probability of finding the atom or molecule in the initial state (2) as well as by the probability of the particular transition $2 \rightarrow 1$.

First we will briefly look for distribution of atoms over the various excited states. For a system in equilibrium at temperature T the ratio of the number of atoms occupying the two energy states E_2 and E_1 is given by Boltzmann's formula:

$$\frac{N_2}{N_1} = \frac{g_2}{g_1} e^{-\frac{E_2 - E_1}{kT}} \quad (2-7)$$

where g is statistical weight of the state and is equal to its degeneracy, that is, to the number of distinct sub-states having the same energy.

The other factor determining the intensity of given spectral line is intrinsic probability of the particular transition and it is defined by Einstein coefficients (Fig. 2-6.)

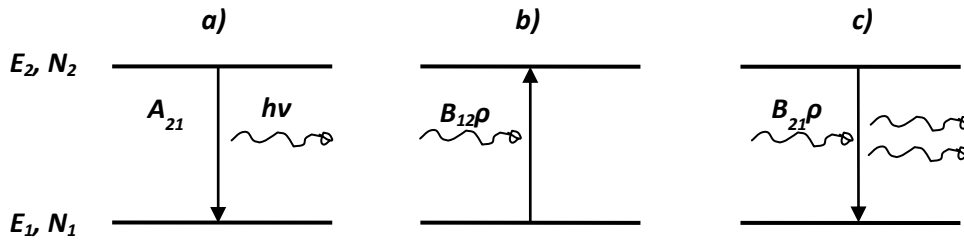

Figure 2-6 Two energy levels E_2 and E_1 populated by N_2 and N_1 atoms per cm^{-3} . a) spontaneous emission b) absorption c) induced transition

There are three possible radiative processes connecting these two levels. First, the atom in level (2) may undergo spontaneously a transition to level (1) with emission of a photon of energy $h\nu_{12}$. The probability of this process is denoted by the coefficient A_{21} . Second, in presence of radiation field of density $\rho(\nu_{12})$ and appropriate frequency ν_{12} an atom in level (1) is excited to level (2) with absorption of a photon with energy $h\nu_{12}$. The probability of this process is denoted by the coefficient B_{12} . Finally, the atom in state (2) in presence of radiation field $\rho(\nu_{12})$ may undergo an induced transition to level (1) with emission of a photon with energy $h\nu_{12}$. The probability for this process is denoted by B_{21} . Coefficients A_{21} , B_{21} and B_{12} are called Einstein coefficients. In particular, the rate of radiative transitions upward into (2) from (1) must equal the rate downward from (2) to (1) according to principle of detailed balancing. Therefore:

$$B_{12}N_1\rho(\nu_{12}) = A_{21}N_2 + B_{21}N_2\rho(\nu_{12}) \quad (2-8)$$

The equation above, together with Boltzmann's and Planck's formula gives the relations between Einstein coefficients:

$$g_1B_{12} = g_2B_{21} \quad (2-9)$$

$$A_{21} = \frac{8\pi h\nu^3}{c^3} B_{21} \quad (2-10)$$

The Einstein coefficients are related to the intrinsic atomic properties and can be calculated from the wave functions. Although derived from thermodynamic equilibrium, they must still hold in any other conditions (at any temperature).

2.3. THERMODYNAMIC EQUILIBRIUM IN PLASMA

Strictly speaking, plasma is an assembly of ions and electrons which is electrically neutral, the total ionic charge being equal to the total number of electrons. However, very often, the word plasma is used for an ionized gas/vapor which is an assembly of atoms, ions and electrons.

Plasma in gas discharges can be in state of complete thermodynamic equilibrium (TE), local thermodynamic (LTE) or partial local thermodynamic equilibrium (PLTE).

THERMODYNAMIC EQUILIBRIUM (TE)

The equilibrium distribution of energy among the different states of an assembly of particles is determined by the temperature as the parameter, defining the temperature, T , for that particular form of energy. Complete thermodynamic equilibrium exists when all forms of energy distribution are described with same temperature. The principle of detailed balance or microscopic reversibility must then operate: each energy exchange process must be balanced by its exact inverse. For each photon emitted, a photon of same frequency must be absorbed, for every excitation by electron collision there must be de-excitation by electron collision, etc. In practice this situation cannot be fully realized, because for each temperature, there are unavoidable energy losses in plasma.

LOCAL THERMODYNAMIC EQUILIBRIUM (LTE)

If the thermodynamic equilibrium condition is valid only in some parts of inhomogeneous plasma, the plasma is in state of local thermodynamic equilibrium. Many types of plasma in laboratory conditions can be described by local thermodynamic equilibrium.

Local thermodynamic equilibrium assumes that kinetic temperature of atoms and ions is equal to electron temperature in plasma. The criterion for LTE is that collisional processes must be much more important than radiative, so that shortfall of the radiative energy does not matter. In the case of stationary plasma, for complete LTE down to the ground state, the collision excitation rate must have much larger probability than the radiative excitation or de-excitation rate, even for the first excited state.

Plasmas can be thermal (where LTE is satisfied) and non-thermal plasmas (where LTE is not satisfied). This distinction is governed by plasma parameters, especially by the pressure in plasma. High pressure indicates that the probability for collision between plasma particles is large enough that the particles exchange energy effectively, and thus have the same temperature. That kind of plasma is in LTE. On the other side, if the pressure in plasma is low, the collisions between particles are rare and the plasma particles have different temperature. That kind of plasma is not in LTE. It is supposed that plasma in high-pressure metal-halide discharges, where the pressure is 1 – 300 bar is in LTE and plasma in low-pressure discharges (pressure much lower than 1 bar) is not in LTE.

For optically thin plasma, where the collision processes dominate, the assumption about LTE can be applied if the electron density satisfies the condition (2-11):

$$N_e = 9 \cdot 10^{17} \sqrt{\frac{k_B T_e}{E_H}} \left(\frac{\Delta E}{E_H}\right)^3, \quad (2-11)$$

where N_e is electron density (cm^{-3}), T_e is the electron temperature, ΔE is the largest difference between two energy states in an atom and E_H is the ionization energy of hydrogen atom (13,6 eV).

The condition above requires rather high electron densities, but can be reduced by order of magnitude if the product of the ground state atom density N_1 , and the discharge dimensions, d , is large enough:

$$N_1 d \geq 4 \cdot 10^9 f_{12}^{-1} \lambda_{12}^{-1} \sqrt{\frac{k_B T_e}{A E_H}}, \quad (2-12)$$

where f_{12} denotes the resonance line oscillator strength, λ_{12} is the wavelength of the line, and A represents the relative atomic mass number. If the equation 2-12 is satisfied, equation 2-11 may be relaxed by an order of magnitude, to the relation:

$$N_e = 10^{17} \sqrt{\frac{k_B T_e}{E_H}} \left(\frac{\Delta E}{E_H}\right)^3. \quad (2-13)$$

To prove the validity of LTE, one must additionally check whether the kinetic temperature of atoms and ions are equal to the electron temperature. This condition is given as:

$$E^2 \ll (5,5 \cdot 10^{-12} N_e \frac{E_H}{k_B T})^2 \frac{m}{M}, \quad (2-14)$$

where E is the applied electric field, and the other symbols have the same meaning as before. In high pressure gas discharges this condition is satisfied and temperature of atoms and ions in plasma is equal to electron temperature within $\pm 2\%$.

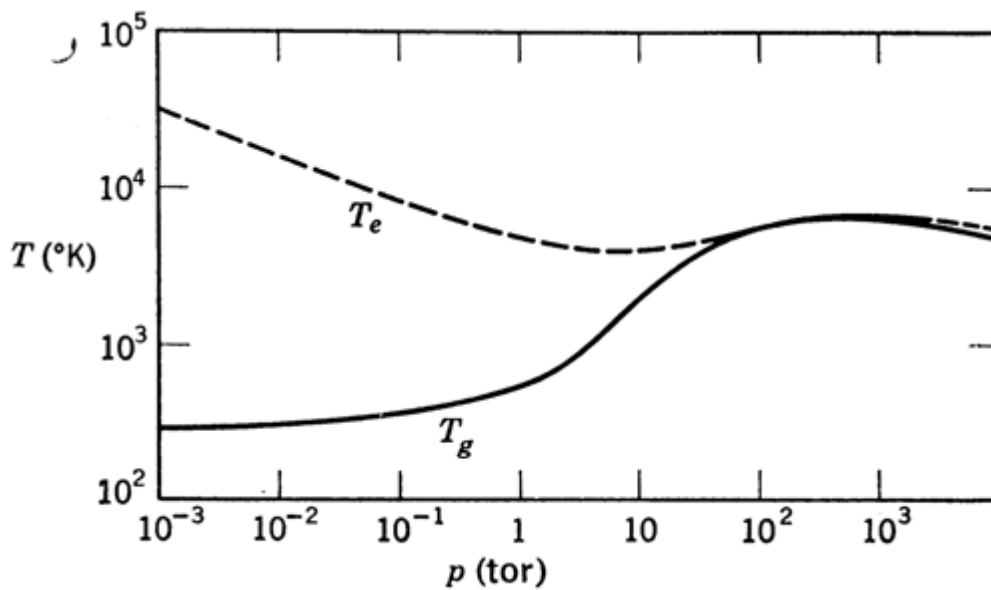

Figure 2-7 Electronic temperature and the temperature of the atoms and ions in plasma as a function of plasma pressure

Metal halide discharges are generally assumed to exhibit local thermodynamic equilibrium (Dakin).

PARTIAL LOCAL THERMODYNAMIC EQUILIBRIUM (PLTE)

Partial local thermodynamic equilibrium supposes that thermodynamic equilibrium is valid only for upper energy states that are closer to ionization continuum.

3. MAIN FEATURES OF PLASMA RADIATION

The investigation of width and shift of spectral lines radiated from plasma can give the information about the main plasma parameters, such as temperature, concentration of neutral particles in plasma, concentration of electron, etc. Also, the shape of lines provides the information about interaction between particles in the discharge.

The most widely used methods for investigation of plasma parameters are spectroscopic methods. These methods are based on analysis of shape of spectral lines.

3.1. WIDTH AND SHAPE OF SPECTRAL LINES (Thorne, 1975)

Any atomic or molecular transition is associated with finite spread of energy, thus the spectral lines in discrete spectra are never strictly monochromatic (Demtroeder, 1998). Even with the very high resolution of the monochromators one observes the spectral distribution $I(\nu)$ of the intensity around the central frequency $\nu_0 = (E_i - E_k)/h$ corresponding to an atomic transition with the energy difference $\Delta E = E_i - E_k$ between upper and lower levels (Fig. 3-1) Width and shape of a spectral line is influenced by several parameters: natural broadening, Doppler broadening and collisional broadening. The complete line shape depends on the particular broadening mechanism. Figure 3-1 shows line profile. Width of the line is usually measured by its full width at half maximum (FWHM) and this is the frequency interval between two frequencies ν_1 and ν_2 for which $I(\nu_1) = I(\nu_2) = 1/2I(\nu_0)$.

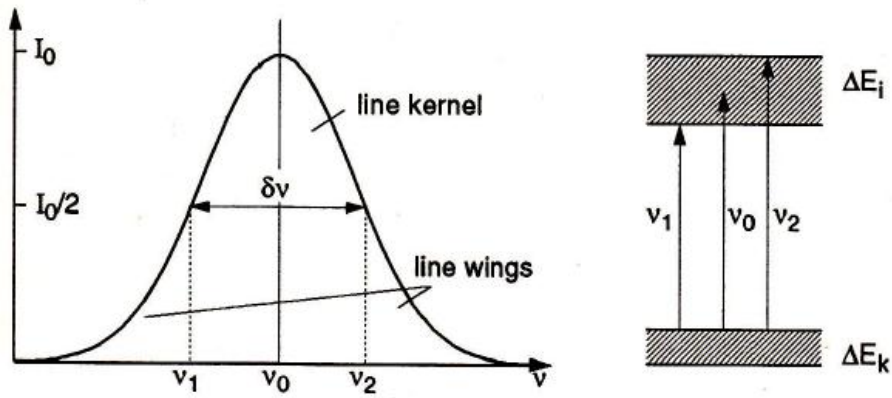

Figure 3-1 Emission line profile and its full width at half maximum (FWHM). FWHM can be expressed in units of frequency $\Delta\nu$, units of wavelength $\Delta\lambda$, or in units of wavenumber Δk . Picture is taken from Demtroeder, Laser Spectroscopy, 1998.

3.1.1. PRESSURE BROADENING

Atoms interact with other particles in plasma: atoms, ions and electrons. These interactions cause shifting and mixing of energy levels and thus broadening and shift of spectral lines (Fig. 3-2)

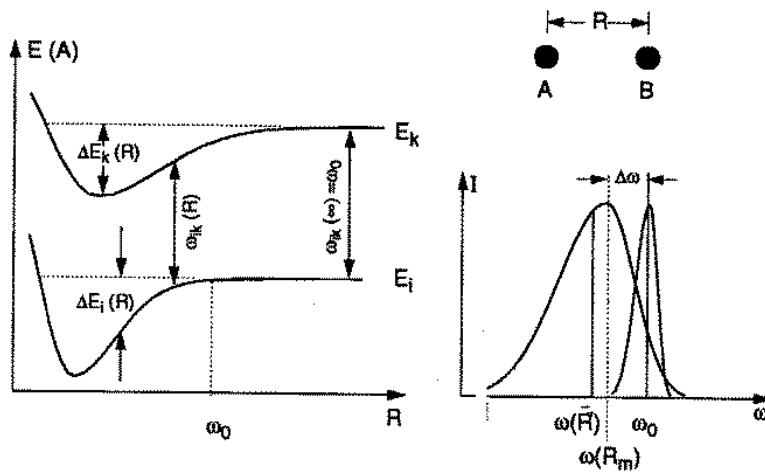

Figure 3-2 Illustration of collisional line broadening and shift explained with the potential curves of the collision pair AB. Picture is taken from Demtröder, Laser Spectroscopy, 1998.

One may classify pressure broadening effects either by the type of the interaction, i.e. perturber (charged particles, neutral atoms), or by the approximations made in treating the perturbation (impact or quasistatic approximation).

The perturbation shifts each energy level E_i of the atom by an amount ΔE_i which depends both on i and on the distance r between two particles (Fig. 3-2). The change of interaction energy based on their mutual distance can be expressed as:

$$\Delta E_{2,1}(r) = E_{2,1}(r \rightarrow \infty) - E_{2,1}(r) \quad (3-1)$$

Compared to the unperturbed frequency $\omega_{2,1}(r \rightarrow \infty) = \omega_0$, the observed spectral line is shifted to frequency $\omega_{2,1}(r)$, and this shift is equal to:

$$\Delta\omega_{2,1}(r) \equiv \omega_0 - \omega_{2,1}(r) = \frac{1}{\hbar} \cdot [\Delta E_2(r) - \Delta E_1(r)] = \frac{\Delta E_{2,1}(r)}{\hbar} \quad (3-2)$$

The equation implies that that kinetic energy is conserved and the collision is elastic, which means that the perturber does not induce any transitions in the emitting atom. This assumption is known as the adiabatic approximation.

For large distances r between two particles interaction between particles is negligible: $E_{2,1}(r \rightarrow \infty) \rightarrow 0$. Any interaction which is a function of r and tends to zero for large r may be expressed as a power series in $1/r$:

$$\Delta\omega_{2,1}(r) = \sum_i \frac{C_i}{r^i} \quad (3-3)$$

If only the first non-vanishing term in the series is kept, we have:

$$\Delta\omega(r) = \frac{C_n}{r^n}, \quad (3-4)$$

where the value of n and the interaction constant C_n depend on the type of interaction considered.

TYPES OF INTERACTION

Three different types of perturber may be distinguished: a) charged particles, b) identical particles and c) neutral particles.

a) Charged particles

An emitting atom at distance r from an ion or electron is perturbed by an electric field $E = \frac{e}{4\pi\epsilon_0 r^2}$ and the interaction between the atom and the field is described by the Stark effect and this type of broadening is called Stark broadening. Perturbation proportional to E exists only in the case of the hydrogen atom. For hydrogen-like ions we have $n = 2$ and constant C_2 is determined by the linear Stark coefficients, which are calculable from the hydrogen wave functions. For all other atoms the first non-vanishing interaction is quadratic Stark effect, proportional to E^2 and hence to $1/r^4$. For these atoms $n = 4$. Constant C_4 can also be calculated from the relevant wave functions, but it is more likely to be found from the experimental determination of the quadratic Stark effect coefficients in a static external electric field.

While the linear Stark effect splits the energy levels symmetrically, resulting in a unshifted and symmetrically broadened line, the quadratic effect, on the other hand, splits the levels asymmetrically and also shifts their center of gravity. A line broadened by the quadratic effect therefore tends to be asymmetric and shifted to longer wavelengths.

b) Identical particles

Resonance interaction occurs only between identical species and is confined to lines with the upper or lower level having an electric dipole transition (resonance line) to the ground state. They take the form of dipole – dipole interaction, for which the n in the equation $\Delta\omega(r) = \frac{C_n}{r^n}$ is 3. An atom in a stationary state has no permanent electric dipole moment, so to understand how this is possible, we consider the quasi-molecule formed by an excited atom A and a nearby identical atom B in the ground state. Because of the identity of the atoms this system is degenerate with the atom A in the ground state and atom B in the excited state. From these two states a non-

degenerate wave function is formed as a linear combination of the two degenerate functions, implying that both atoms A and B are partly in ground state and partly excited. Interaction constant C_3 is proportional to oscillator strength f_{21} which is determined by the Einstein coefficients for a given transition. Resonance interactions give symmetrically broadened, unshifted lines and this type of broadening is mostly the focus of our research.

c) Neutral particles

Van der Waals forces appear between any two atoms or molecules, but they have a smaller range than either of the other two types considered so far. They take the form of a fixed dipole-induced dipole interaction. This type of interaction is described with the $n = 6$ in $\Delta\omega(r) = \frac{C_n}{r^n}$ which leads to potential proportional to $1/r^6$. Energy of the Van der Waals interaction is always negative which corresponds to an attractive force. It is generally larger for the highest excited levels and for the heaviest atoms.

METHODS OF APPROACH

We start with the assumption that the perturbation takes the form of quenching collision, cutting of the wave front abruptly and that the collision involves only one perturber – the so called binary interaction approximation.

IMPACT THEORY (Lochte-Holtgreven, 1968)

To introduce the impact theory, three assumptions, known as binary, classical path and adiabatic approximation, are necessary. The binary approximation assumes that only one perturber at time interacts with the exciting atom; the approximation of classical path assumes the perturber to move along a classical path, i.e. along a straight line; and adiabatic

approximation assumes that the perturbers do not induce transitions between different close-lying states of the emitting atom.

Collisions in impact theory are assumed to cause phase changes in the radiated wave train, but not to cut it short by knocking the radiating atom out of its excited state. The main cause of broadening of the spectral lines according to impact theory is cutting off the coherent oscillations of atom oscillator during the collision.

Intensity of spectral line on the frequency $\Delta\omega$ that corresponds to frequency $\Delta\omega_{12}$ from equation 3-2 is determined with the radiation radiated in the time interval Δt :

$$\Delta t \approx \frac{1}{\Delta\omega}, \quad (3-5)$$

that corresponds to the time t_u between two collisions. This time is compared with the duration of the perturbation t_p :

$$t_p = \frac{\rho}{\bar{v}}, \quad (3-6)$$

where ρ is the impact parameter and \bar{v} is the mean velocity of the perturber. If the duration of the perturbation is small compared to time between the collisions, $t_u \gg t_p$, the radiation during the collision can be neglected and the assumption of the discrete, separated collision is valid. The interaction during the collision changes only the phase of the oscillation. The total phase change $\varphi(t)$ is thus the function of impact parameter ρ .

The change of phase, caused by the perturbation $\Delta\omega$ over the duration of the collision is:

$$\varphi(\rho) = \int_{-\infty}^{\infty} \Delta\omega(r) dt, \quad (3-7)$$

where the change in the limits of the integration alters nothing because $\Delta\omega$ is zero outside of perturbation period t_p .

The phase change approximately equals to the product of the frequency change and the collision duration:

$$\varphi(\rho) \cong \Delta\omega(\rho) \cdot \frac{\rho}{\bar{v}}. \quad (3-8)$$

Writing the interaction in the form of equation 3-4:

$$\Delta\omega(r) = \frac{C_n}{r^{n'}} \quad (3-9)$$

where r is the distance between an emitting atom and perturber (Fig. 3-3) and $r = \frac{\rho}{\cos\theta}$, the phase change equals:

$$\varphi(\rho) = \int_{-\pi/2}^{\pi/2} \frac{C_n \cos^{n-2}\theta}{\rho^{n-1} \cdot \bar{v}} \cdot d\theta = \frac{a_n C_n}{\rho^{n-1} \bar{v}} \quad (3-10)$$

where a_n is a numerical constant of order unity, depending on the power n .

For $\varphi(\rho) = 1 \text{ rad}$, the appropriate impact parameter is:

$$\rho_W = \left(\frac{a_n C_n}{\bar{v}} \right)^{\frac{1}{n-1}}, \quad (3-11)$$

where ρ_W is known as Weisskopf radius.

The number of collisions per second for which $\rho \leq \rho_W$ is $\pi \rho_W^2 \bar{v} N$, where N is the number density of the perturber.

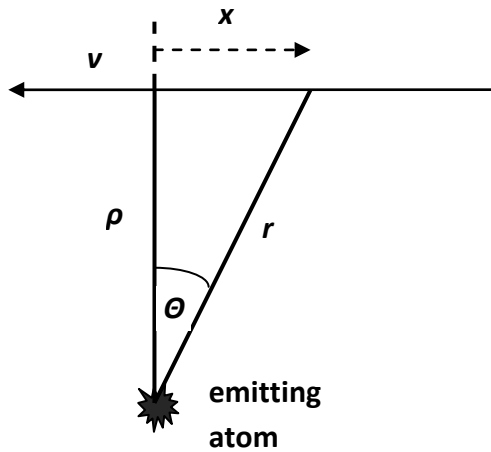

Figure 3-3 Geometry for calculating phase change

If the perturber moves in a straight line with the mean velocity \bar{v} , and impact parameter is equal to Weisskopf radius, time $\frac{\rho_W}{\bar{v}}$ represents the duration of perturbation t_p .

Spectral line in impact approximation has Lorentz profile:

$$P_{im}(\Delta\omega) = \frac{\Delta\omega_{im}}{2\pi} \cdot \frac{1}{(\omega - \delta\omega)^2 + (\frac{\Delta\omega_{im}}{2})^2}, \quad (3-12)$$

where $\Delta\omega_{im}$ is the width of the spectral line and it equals:

$$\Delta\omega_{im} = 2N\bar{v}\sigma_r, \quad (3-13)$$

and $\delta\omega$ is the shift of the spectral line from the position of the unperturbed spectral line:

$$\delta\omega_{im} = N\bar{v}\sigma_i. \quad (3-14)$$

σ_r and σ_i are the real and imaginary part of the effective impact cross-section σ :

$$\sigma_r = 2\pi \int_0^\infty (1 - \cos\varphi)\rho d\rho, \quad \sigma_i = 2\pi \int_0^\infty \sin\varphi \cdot \rho d\rho. \quad (3-15)$$

Thus, according to Weisskopf theory, the width of the spectral line equals:

$$\Delta\omega_{im} = 2\pi N \left(\frac{C_n a_n}{\bar{v}}\right)^{\frac{2}{n-1}} \cdot \bar{v}. \quad (3-16)$$

By looking equations 3-13 and 3-14 qualitatively, one can deduce that the weak collisions (large ρ , small φ) are responsible for line shift, and the strong collisions (small ρ , large φ) are responsible for the most of the broadening. Collisions for which $\rho \sim \rho_W$ are responsible for the most of the line broadening, while collisions for which $\rho \gg \rho_W$ cause the most of the shift.

Wiesskopf theory gives the good description of the impact of the neutral atoms on the broadening of the spectral lines, while for the electrons the results are not satisfactory. Using this theory, because of assumption of the impact of only strong collisions, ($\varphi(\rho) \geq 1$), the shift of spectral lines observed in Stark and Van der Waal's broadening cannot be calculated. Thus, it is necessary to take into account the weak collisions ($\varphi(\rho) \leq 1$) and phase shifts during strong collisions. Theory of the phase changes due to different perturber is introduced by Lindholm and Foley and Anderson (Lochte-Holtgreven, 1968). Calculated values for width and shift of spectral lines for resonant, Stark and Van der Waal's interaction are given in Table 3-1.

Table 3-1 Calculated values for width ($\Delta\omega_{im}$) and shift ($\delta\omega_{im}$) of spectral lines for resonant, Stark and Van der Waal's interaction according to Lindholm-Foley impact theory

Type of interaction	n	a_n	$\Delta\omega_{im}$	$\delta\omega_{im}$
Resonant interaction	3	2	$= 2\pi^2 C_3 N$	0
Stark effect	4	$\pi/2$	$= 11.37 \cdot C_4^{2/3} \bar{v}^{1/3} N$	$= \frac{\sqrt{3}}{2} \cdot \Delta\omega_{im}$
Van der Waal's interaction	6	$3\pi/8$	$\approx 8.16 \cdot C_6^{2/5} \bar{v}^{3/5} N$	$\approx 0.36 \cdot \Delta\omega_{im}$

The main contribution to the broadening of the spectral lines comes from strong collisions, for which is valid: $\varphi \geq 1$ and $\rho \leq \rho_W$, while the main contribution to the shift of spectral lines comes from the weak collisions for which $\rho \geq \rho_W$.

As already said before, the impact theory works for discrete, separated collisions, and these are tenable only over the frequency range defined by:

$$\Delta\omega = |\omega_0 - \omega| \ll \frac{\bar{v}}{\rho_W}. \quad (3-17)$$

The impact theory becomes unrealistic in the following conditions:

- If the perturber is slow-moving, and the small \bar{v} leads to large value of collision time t_p
- If the density of the perturbers is high – this leads to small time between collisions t_u
- At the line wings, where $\Delta\omega$ is large
- In the field of long-range forces, where the Wiesskopf radius is large and the collision time is also large.

From these considerations, the impact approximation may be expected to break down with increasing pressure (b), in the wings of the line (c), for charged perturbers before neutrals (d) and for ions before electrons (a).

QUASI-STATIC THEORY (Sobel'man, 1972)

This theory starts from the assumption that the perturbers are almost stationary and the perturbation is nearly constant over the whole time that the emitting atom is radiating. There are two steps to be taken: first, to calculate the effect of a single perturber on the emitter, and secondly, to perform a statistical average over all perturbers.

If the external field, that is due to the perturber, varies sufficiently slowly (if it is quasi-static), it is possible to assume that the intensity distribution in some frequency interval, $I(\omega)d\omega$, is simply proportional to the statistical weight of the configuration of the configuration of perturbing particles for which the frequency of the atomic oscillator is included in the interval $\omega, \omega + \Delta\omega$. The simplest static theory assumes the frequency shift $\Delta\omega$ as being due only to the nearest neighbor. To calculate $I(\omega)$, it is necessary to find the probability $W(r)dr$ of the nearest particle being within the range of distance $(r, r + \Delta r)$ from the atom. For r much larger than the atomic dimensions the interaction potential can be neglected and this probability is:

$$W(r)dr = 4\pi r^2 e^{-\frac{4\pi}{3}Nr^3} dr = e^{-\left(\frac{r}{R_0}\right)^3} d\left(\frac{r}{R_0}\right)^3, \quad (3-18)$$

where R_0 is the mean distance around emitting atom with one perturber in it:

$$R_0 = \left(\frac{3}{4}\pi N\right)^{1/3}. \quad (3-19)$$

According to quasi-static approximation, frequency shift of emitting atom written as:

$$\Delta\omega(r) = \frac{C_n}{r^n}, \quad (3-20)$$

where C_n is constant characteristic for particular interaction, is considered as the shift of energy states.

Substituting r from equation... in equation..., the probability distribution for frequency shift of an atomic oscillator is obtained. In accordance with the basic assumption of the quasi-static approximation, the shape of the spectral line is also determined by this distribution:

$$I(\omega)d\omega = \frac{4\pi}{n} NC_n^{\frac{3}{n}}(\omega - \omega_0)^{-(3+n)/n} e^{-\left(\frac{\overline{\Delta\omega}}{\omega - \omega_0}\right)^{3/n}} d\omega, \quad (3-21)$$

where $\overline{\Delta\omega} = \frac{C_n}{R_0^n}$.

Distribution above is valid only for sufficiently large values of $\omega - \omega_0$ for which

$r = \left(\frac{C_n}{\omega - \omega_0}\right)^{1/n} \ll R_0$. For $r \geq R_0$, the binary approximation is not valid. Thus, the equation ... is valid only for the frequencies in the line wings (far away from the center of the line). The condition $r \ll R_0$ means that $\overline{\Delta\omega} \ll \omega - \omega_0$. Thus the exponential factor in equation 3-21 can be omitted, after which it is obtained:

$$I(\omega)d\omega = \frac{4\pi}{n} NC_n^{\frac{3}{n}}(\omega - \omega_0)^{-(3+n)/n} d\omega. \quad (3-22)$$

3.1.2. NATURAL BROADENING

Electromagnetic radiation emitted by a single atom during transition from one to another energy state is not completely monochromatic and every emitted line has some finite width. Natural width of the line can be explained either from classical or from the quantum mechanical point of view.

The classical picture used to explain natural broadening with an electron performing damped simple harmonic motion at characteristic frequency:

$$\ddot{x} + \gamma\dot{x} + \omega_0^2 x = 0 \quad (3-23)$$

where ω_0 is the characteristic angular frequency and γ is damping constant which represents radiation loss of energy:

$$\gamma = \frac{e^2 \omega_0^2}{6\pi \epsilon_0 m c^3}. \quad (3-24)$$

For small damping the solution of the equation above is $x(t) = x_0 e^{-\frac{\gamma}{2t}} \cdot \cos \omega_0 t$.

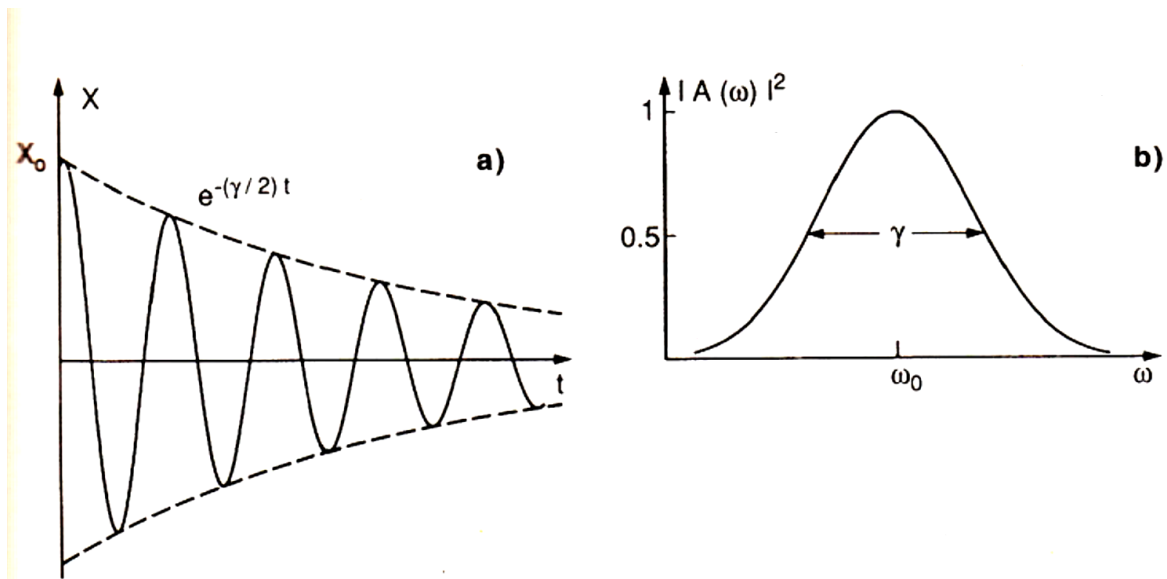

Figure 3-4 Damped oscillation with amplitude decaying as $e^{-\frac{\gamma}{2t}}$ (a) and corresponding line profile

The damped oscillations have the form shown in Figure 3-4, with the amplitude decaying as $e^{-\frac{\gamma}{2t}}$. Thus, the oscillations can be thought of as having a lifetime $\tau = \frac{1}{\gamma}$. Only an infinite wave train of constant amplitude is truly monochromatic. A pulse of finite duration can be formed only by superposing waves with a spread of frequency around ω_0 . This spread can be found by Fourier analysis, which effectively determines the amplitude of each frequency component $A(\omega)$ required to build up the pulse $x(t) = x_0 e^{-\frac{\gamma}{2t}} \cdot \cos \omega_0 t$. $A(\omega)$ is a complex function and AA^* gives the intensity $I(\omega)$ as a function of frequency. The result of the Fourier transform for $t = 0$ to $t = \infty$ is the Lorentzian or (dispersion) distribution:

$$I(\omega) = I_0 \cdot \frac{\frac{\gamma}{2\pi}}{(\omega - \omega_0)^2 + (\frac{\gamma}{2})^2} = I_0 L(\omega - \omega_0), \quad (3-25)$$

where I_0 is central intensity.

Normalized Lorentz function is equal to:

$$L(\omega - \omega_0) = \frac{1}{2\pi} \cdot \frac{\gamma}{(\omega - \omega_0)^2 + (\frac{\gamma}{2})^2}. \quad (3-26)$$

Natural line width (FWHM) described by Lorentz distribution equals γ , while the maximum intensity is (Figure):

$$L(0) = \frac{2}{\pi\gamma}. \quad (3-27)$$

Natural width of the spectral line can also be looked from quantum mechanical point of view. Absorption and emission consists of transitions between two discrete energy levels. But, because of the uncertainty principle, these levels cannot be infinitely narrow. Uncertainty principle $\Delta E \cdot \Delta t \sim \hbar$ requires the energy spread $\Delta E \sim \hbar/\Delta t$, where Δt is the uncertainty in time associated with finding the atom in that particular state and is measured by the mean lifetime τ of the state. From energy spread the frequency spread is equal $\Delta\omega \cdot \Delta t \sim 1$. The frequency spread for the state j can thus be written $\Delta\omega_j \approx \frac{1}{\tau_j} \cdot \Delta\omega_j$ and is negligible for the ground and metastable state. Upper states of allowed optical transitions have lifetimes of order 10^{-6} to 10^{-9} s.

Figure 3-5 shows the situation when both levels are broadened. The width of the line is then given by $\Delta\omega_{12} = \Delta\omega_1 + \Delta\omega_2$

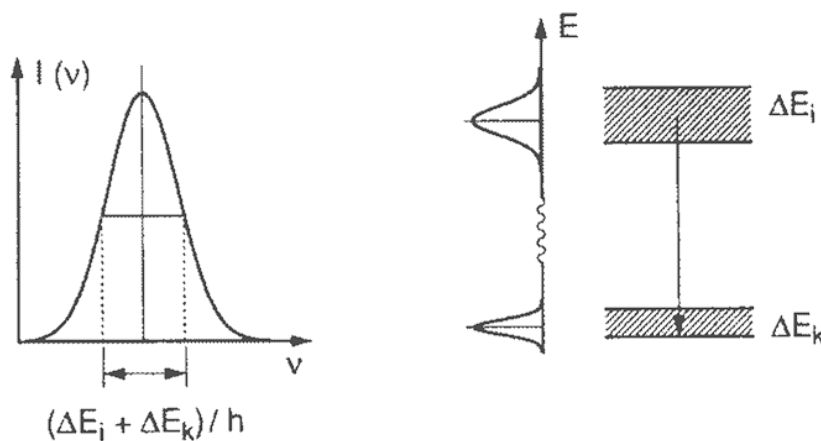

Figure 3-5 Illustration of uncertainty principle which relates the natural line width to the energy uncertainties of upper and lower level

The lifetime of excited state, in absence of collisions, is related to transition probability for spontaneous emission A_{21} by $\tau_2 = 1/A_{21}$, and if more than one transition from level 2 is possible, by $\tau_2 = 1/\sum_i A_{2i}$. Because the transition probability is proportional to ν^3 , natural

line width decreases rapidly in the infra-red (micro-wave) regions, but is appreciable in the far ultra-violet.

3.2.1. DOPPLER BROADENING

In previous chapter, when describing natural broadening it was assumed that atoms, that emit or absorb the radiation, are isolated and at rest. This chapter describes how thermal movement of isolated atoms and molecules influences the width of spectral lines.

Doppler broadening is the result of thermal movement of atoms in random directions with a velocity distribution given by the Maxwell distribution.

Consider the atom with velocity $\vec{v} = (v_x, v_y, v_z)$ in the field of the monochromatic electromagnetic radiation of frequency ω_z and wave vector $\vec{k} = (k_x, k_y, k_z)$.

In the system of moving atom the electromagnetic radiation will have the frequency:

$$\omega_{at} = \omega_z - \vec{k} \cdot \vec{v}, \quad (3-28)$$

which means that the frequency observed by moving atom will be raised if the radiation approaches to the atom, while in that case vectors \vec{k} and \vec{v} have opposite directions.

An atom will absorb the radiation only if the observed frequency of the radiation ω_{at} is equal to the frequency of its atomic transition ω_0 . From this it can be written:

$$\omega_0 = \omega_{at} = \omega_z - \vec{k} \cdot \vec{v}, \quad (3-29)$$

and the frequency that an atom will absorb can be determined:

$$\omega = \omega_z = \omega_0 + \vec{k} \cdot \vec{v}. \quad (3-30)$$

If we suppose that the vector of electromagnetic radiation is in the x axis, the above expression can be written as:

$$\omega = \omega_0 + k \cdot v_x = \omega_0 \left(1 + \frac{v_x}{c}\right). \quad (3-31)$$

The number of atoms n_k on the energy level E_k with the velocity component between v_x and v_x+dv_x is determined with Maxwell distribution:

$$n_k(v_x)dv_x = \frac{N_k}{v_p \cdot \sqrt{\pi}} \cdot e^{-\left(\frac{v_x}{v_p}\right)^2} dv_x, \quad (3-32)$$

where v_p is the most probable velocity and N_k is the number of all atoms on the energy level E_k :

$$v_p = \sqrt{\frac{2k_B T}{m}}, \quad (3-33)$$

$$N_k = \int n_k(v_x)dv_x. \quad (3-34)$$

T is the temperature as a measure of kinetic energy of atoms.

Since the intensity at ω is proportional to number of atoms having frequency between ω and $\omega + d\omega$, the line profile of the Doppler broadened line can be written in terms of the central intensity I_0 as:

$$I(\omega) = I_0 \cdot e^{-\left(\frac{v_x}{v_p}\right)^2} = I_0 \cdot e^{-\left(\frac{c(\omega-\omega_0)}{\omega_0 v_p}\right)^2}. \quad (3-35)$$

This is a Gaussian distribution about the central frequency ω_0 , where the full width at half maximum, $\Delta\omega_D$ is:

$$\Delta\omega_D = \frac{2 \cdot \sqrt{\ln 2} \cdot \omega_0 \cdot v_p}{c} = \Delta \cdot \sqrt{\ln 2}, \quad (3-36)$$

$$\Delta = 2 \cdot \frac{\omega_0}{c} \cdot \sqrt{\frac{2kT}{m}}. \quad (3-37)$$

Doppler broadening is the main reason of line broadening of low pressure discharges, while in the high pressure discharges, that are the focus of this research, its contribution, compared to other causes of line broadening is negligible.

In visible region it is normally a couple of orders of magnitude smaller than Doppler broadening.

3.2.2. COMBINATION OF GAUSSIAN AND LORENTZIAN LINE PROFILES

In the frequent cases when a pressure broadened line can be represented by a Lorentzian, the combination of a pressure and natural broadening is also a Lorentzian, with damping constant $\gamma = \gamma_{nat} + \gamma_{coll}$, where in practice usually $\gamma_{nat} \ll \gamma_{coll}$. Since the Doppler broadening produces a Gaussian profile, observed spectral lines are convolution of Gaussian and Lorentzian profile. The actual line shape is obtained by folding the two profiles together. The profile resulting from the convolution of two broadening mechanisms, one of which alone would produce a Gaussian profile, and the other would produce a Lorentzian profile is called the Voigt profile and is of great practical importance. A Voigt profile describes the overall shape of a spectral line.

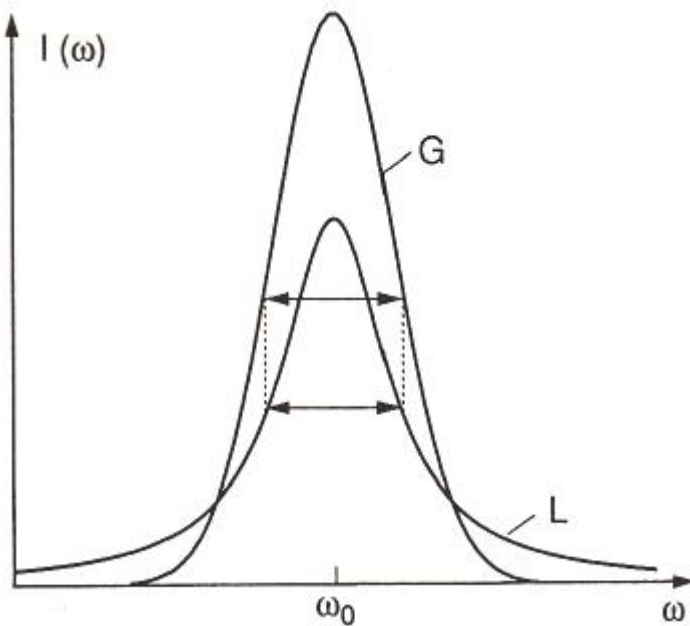

Figure 3-6 Comparison of Lorentzian and Doppler line profiles of equal FWHM

All normalized line profiles can be considered to be probability distributions. The Gaussian profile is equivalent to a Gaussian or normal distribution and a Lorentzian profile is equivalent to a Lorentz or Cauchy distribution. Without loss of generality, we can consider only centered profiles which peak at zero. The Voigt profile is then a convolution of a Lorentz profile and a Gaussian profile:

$$V(x; \sigma, \gamma) = \int_{-\infty}^{\infty} G(x'; \sigma) L(x - x'; \gamma) dx' \quad (3-38)$$

where x is frequency from line center, $G(x; \sigma)$ is the centered Gaussian profile and $L(x; \gamma)$ is the centered Lorentzian profile.

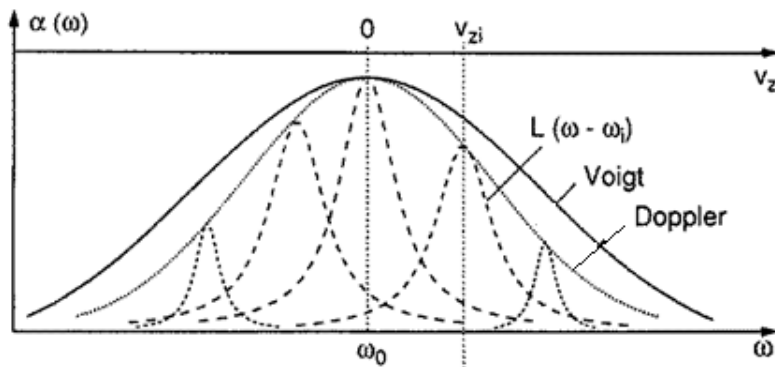

Figure 3-7 Voigt profile as convolution of Lorentzian line shapes

Two measurements can be convolved when the statistical effects that cause broadening are independent. In our case Voigt profile is a convolution of Gaussian profile that carries the information about the instrumental function and Lorentz profile that carries information about pressure broadening.

3.2. SELF-ABSORPTION

Optical depth, or optical thickness, is a measure of transparency of plasma for radiation emerging from the plasma. The spectral lines in plasma can be optically thin or optically thick or something in between. The optically thick lines, due to self-absorption, have specific shape – they are very broad and have the platform or the hole in the center of the spectral line. Radiating atoms in plasma are surrounded by the same atoms that can absorb that radiation. Self-absorption is process in which the radiation that corresponds to wavelengths close to center of the spectral line is reabsorbed by the atoms in the ground energy state.

The most widely used methods for determining the plasma parameters are based on optically thin spectral lines (Lochte-Holtgreven, 1968). Measurement of temperature using the Boltzmann equation requires that spectral lines used are optically thin. If this condition is not satisfied, that is, if the lines used for characterization suffer from self-absorption, their line profiles are saturated, showing distorted widths and areas, leading to wrong values of electron and atom density and temperature.

One of the methods how we can check if the lines are optically thin is shown in figure 3-8.

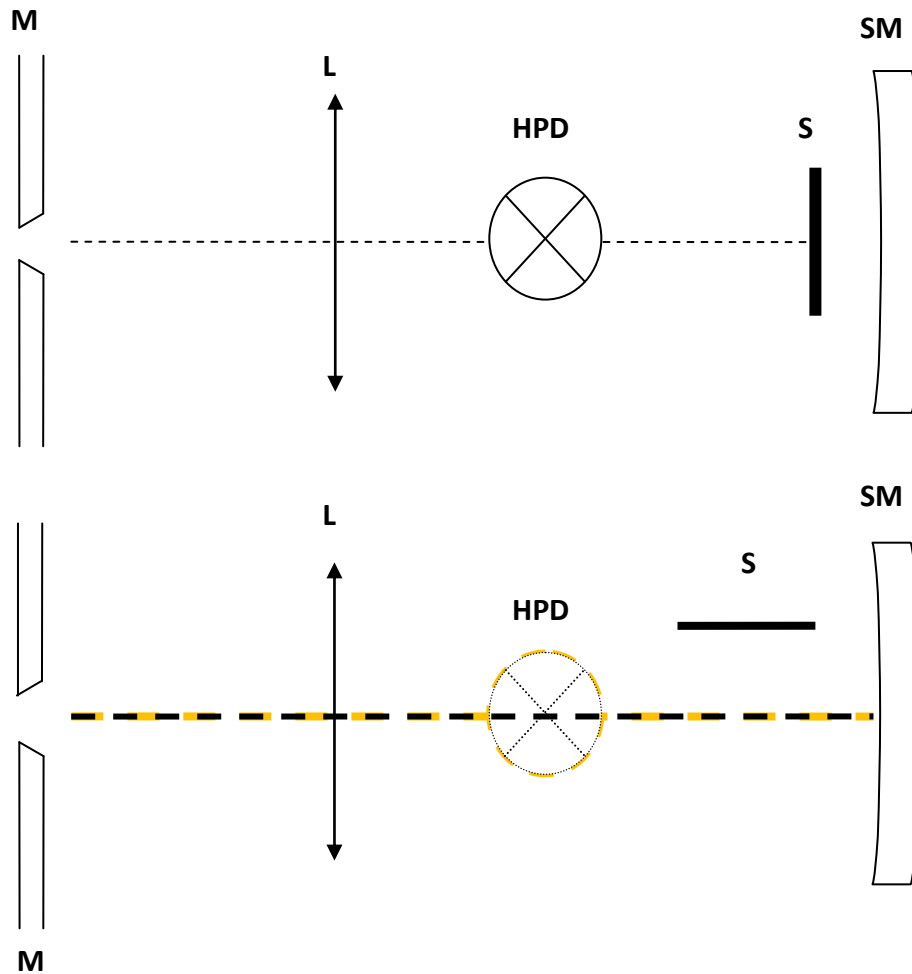

Figure 3-8 Schemes for checking if the lines are optically thin. In a) the mirror was covered and only light from plasma was recorded and in b) the mirror behind plasma was used. M = monochromator, L = lens, HPD = high pressure discharge, S = shade, SM = spherical mirror

As shown in Figure 3-8, a spherical mirror is placed behind the plasma. The mirror is located at twice the value of its focal length from plasma, in order to obtain the image of the plasma column at the place of original plasma. Two line profiles (with and without mirror) are used for the determination of self-absorption coefficient K_λ (Moon, Herrera, Omenetto, Smith, & Winefordner, 2009).

Self-absorption is introduced in the basic derivation of the thermal spectral radiance of a transition. This can be written as follows:

$$B_\lambda(\lambda) = \left(\frac{A_{21}n_2hc}{4\pi\lambda_0}\right)S_\lambda(\lambda) \frac{\{1 - e^{-k_\lambda^*(\lambda)l}\}}{k_\lambda^*(\lambda)}, \quad (3-39)$$

where B_λ is spectral radiance ($\text{Wcm}^{-2}\text{sr}^{-1}\text{cm}^{-1}$) of the emission line, A_{ul} is transition probability (s^{-1}), n_u is the population of the excited level u , $S_\lambda(\lambda)$ is the spectral profile of the line (cm^{-1}), l (cm) is the emission path length in the direction of the observation and k_λ^* (cm^{-1}) is the net absorption coefficient defined by the difference in the population of the lower and upper levels of the transition. If the right hand side term is multiplied and divided by l , we obtain the equation below:

$$B_\lambda(\lambda) = \left(\frac{A_{ul}n_u hc}{4\pi\lambda_0}\right)S_\lambda(\lambda)\left(\frac{l}{K_\lambda}\right). \quad (3-40)$$

The parameter K_λ defined as:

$$K_\lambda \equiv \frac{k_\lambda^*(\lambda)l}{\{1 - e^{-k_\lambda^*(\lambda)l}\}}, \quad (3-41)$$

is called self-absorption coefficient.

Spectral radiance from the above expression can be written as

$$B_\lambda = B_\lambda^{BB}[1 - e^{-k_\lambda l}], \quad (3-42)$$

where B_λ^{BB} is the spectral radiance of the Blackbody radiation,

$$B_\lambda^{BB} = \frac{\rho(\lambda, T)c}{4\pi} d\lambda = \frac{2hc^2}{\lambda^5} \cdot \frac{1}{e^{\frac{hc}{\lambda kT}} - 1} d\lambda. \quad (3-43)$$

Using this expression, the expressions for the spectral radiances with and without mirror can be written:

$$B_{\lambda,1} = B_\lambda^{BB}[1 - e^{-k_\lambda l}], \quad (3-44)$$

$$B_{\lambda,2} = B_{\lambda,1} + GB_{\lambda,1}e^{-k_\lambda l} = B_{\lambda,1}[1 + Ge^{-k_\lambda l}]. \quad (3-45)$$

where suffices 1 and 2 refer to measurements taken without and with the mirror. The parameter G includes reflection and absorption losses and can be evaluated by measuring the R_λ in the far line-wings, where $k_\lambda = 0$:

$$R^C = \frac{B_{\lambda,2}^C}{B_{\lambda,1}^C} = 1 + G. \quad (3-50)$$

The ratio of spectral radiances with and without mirror is:

$$R_{\lambda} = \frac{B_{\lambda,2}}{B_{\lambda,1}} = 1 + Ge^{-k_{\lambda}l}. \quad (3-51)$$

Using equations above, the optical depth can be expressed as:

$$k_{\lambda}l = \ln \frac{R^C - 1}{R_{\lambda} - 1}. \quad (3-52)$$

Finally, the experimental correction factor, $K_{\lambda,corr}$ can be calculated from experimental factors R^C and R_{λ} :

$$K_{\lambda,corr} = \ln \frac{\left[\frac{R^C - 1}{R_{\lambda} - 1} \right]}{1 - \frac{R^C - 1}{R_{\lambda} - 1}}. \quad (3-53)$$

$K_{\lambda,corr}$ can be applied to the weakly or moderately self-absorbed line profile to retrieve the optically thin line profile.

3.3. DETERMINATION OF PLASMA PARAMETERS

The most widely used methods for determining the plasma parameters are based on the emission of spectral lines which are optically thin (Aragon & Aguilera, 2008). Methods of characterization of not optically thin conditions are briefly described in chapter 3.3.3.

3.3.1. TRANSFORMATION OF THE OBSERVED RADIANCES INTO RADIAL DISTRIBUTION OF THE EMISSION OF PLASMA (Bockasten, 1961)

For optically thin axially symmetric plasmas it is possible to calculate the radial distribution of emission coefficients from the observed radiances.

Figure 3-9 shows a circular disk of plasma with the thickness Δz parallel to the xy plane. The photon emitters are assumed to have an axially symmetric distribution with respect to the z axis. The radiation is considered to be isotropic and there is assumed no absorption in plasma. $I(x)$ denotes radiance in the y direction at distance x from the yz plane (in W/m^2sr).

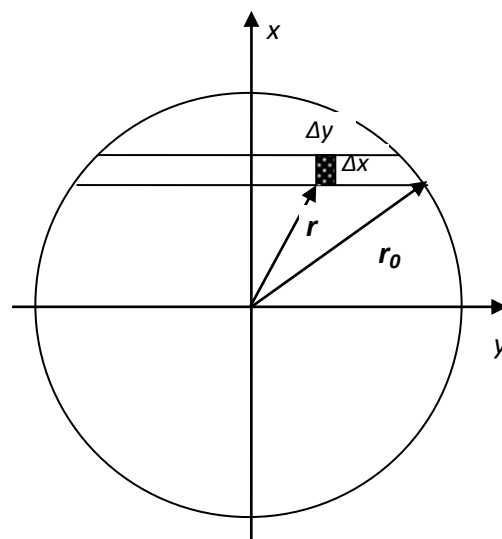

Figure 3-9 A disk of plasma, axially symmetric with respect to the z axis, which is normal to the paper

Our interests are emission coefficients of the plasma $\varepsilon_\lambda(r)$ at the distance r from the origin (in energy per unit time, unit volume, unit frequency interval and unit solid angle). In the

plasma column of length $2y_0$ and cross section $\Delta x \Delta z$ spectral radiance and emission coefficients are related as:

$$I(x) \Delta x \Delta z = \sum_{-y_0}^{+y_0} \varepsilon(r) \Delta x \Delta y \Delta z. \quad (3-54)$$

Passing over to infinitely small volume elements and using the symmetry we get:

$$I(x) = 2 \int_0^{y_0} \varepsilon(r) dy. \quad (3-55)$$

Introducing the substitution $y = (r^2 - x^2)^{\frac{1}{2}}$ the equation above is transformed to:

$$I(x) = 2 \int_x^{r_0} \frac{\varepsilon(r) r dr}{(r^2 - x^2)^{\frac{1}{2}}}. \quad (3-56)$$

Using Abel's transformation (Bockasten, 1961) this equation can be transformed to:

$$\varepsilon(r) = -\frac{1}{\pi} \int_r^{r_0} \frac{I'(x) dx}{(r^2 - x^2)^{\frac{1}{2}}}, \quad (3-57)$$

where $I(x)$ is the distribution of observed radiances (lateral intensities) and $\varepsilon(r)$ is the radially dependent distribution of the emission coefficients.

The observations give $I(x)$ as a number of points through a curve that can be traced. From the curve a sequence of readings I_k can be introduced, for equidistant x values, $x_k = \frac{kr_0}{n}$ ($k = 0, 1, 2, \dots, n - 1$), where r_0 is radius of radiating plasma. We take r_0 as the point where the $I(x)$ equals 10% from the maximum intensity. In the calculations, we take $n = 10$.

From the I_k a number of values called ε_j corresponding to $r_j = \frac{jr_0}{n}$ ($j = 0, 1, 2, \dots, n - 1$) can be calculated using AT given by:

$$\varepsilon_j = r_0^{-1} \sum_k a_{jk} I_k, \quad (3-58)$$

where a_{jk} are certain coefficients (Bockasten, 1961).

Coefficients used in transformations are given in Table I.

Table 3-2 Coefficients a_{jk} for transforming observed radiances $I(x)$ into emission coefficients $\epsilon(r)$.

	j = 0	j = 1	j = 2	j = 3	j = 4	j = 5	j = 6	j = 7	j = 8	j = 9
k = 0	7.62597	0.46341								
k = 1	-5.8009	3.6063	0.32395							
k = 2	-0.5847	-2.9512	2.65384	0.26318						
k = 3	-0.3394	-0.1824	-2.0583	2.19858	0.22728					
k = 4	-0.1970	-0.2148	-0.1387	-1.6660	1.91841	0.20292				
k = 5	-0.1268	-0.1346	-0.1625	-0.1123	-1.4349	1.72380	0.18502			
k = 6	-0.0882	-0.0920	-0.1050	-0.1338	-0.0956	-1.2785	1.57851	0.17114		
k = 7	-0.0649	-0.0669	-0.0736	-0.0876	-0.1155	-0.0841	-1.1640	1.46469	0.15997	
k = 8	-0.0482	-0.0494	-0.0531	-0.0606	-0.0742	-0.1004	-0.0726	-1.0707	1.38185	0.25140
k = 9	-0.0448	-0.0457	-0.0483	-0.0533	-0.0619	-0.0769	-0.1049	-0.0864	-1.0372	0.98415

3.3.2. MEASUREMENT OF ATOMIC DENSITY

In the high pressure discharges with Hg as a main constituent of the plasma, resonance broadening of selected Hg lines provides a simple and reliable Hg density diagnostics (Lawler, 2004). The resonance broadening coefficient in the impact approximation is temperature independent and is known from the quantum theory calculations to a few percent, or to the accuracy of resonance transition probability A_r . Resonance broadening affects all transitions connected to the resonance level and the basic theory is already described in chapter 2.2.4.

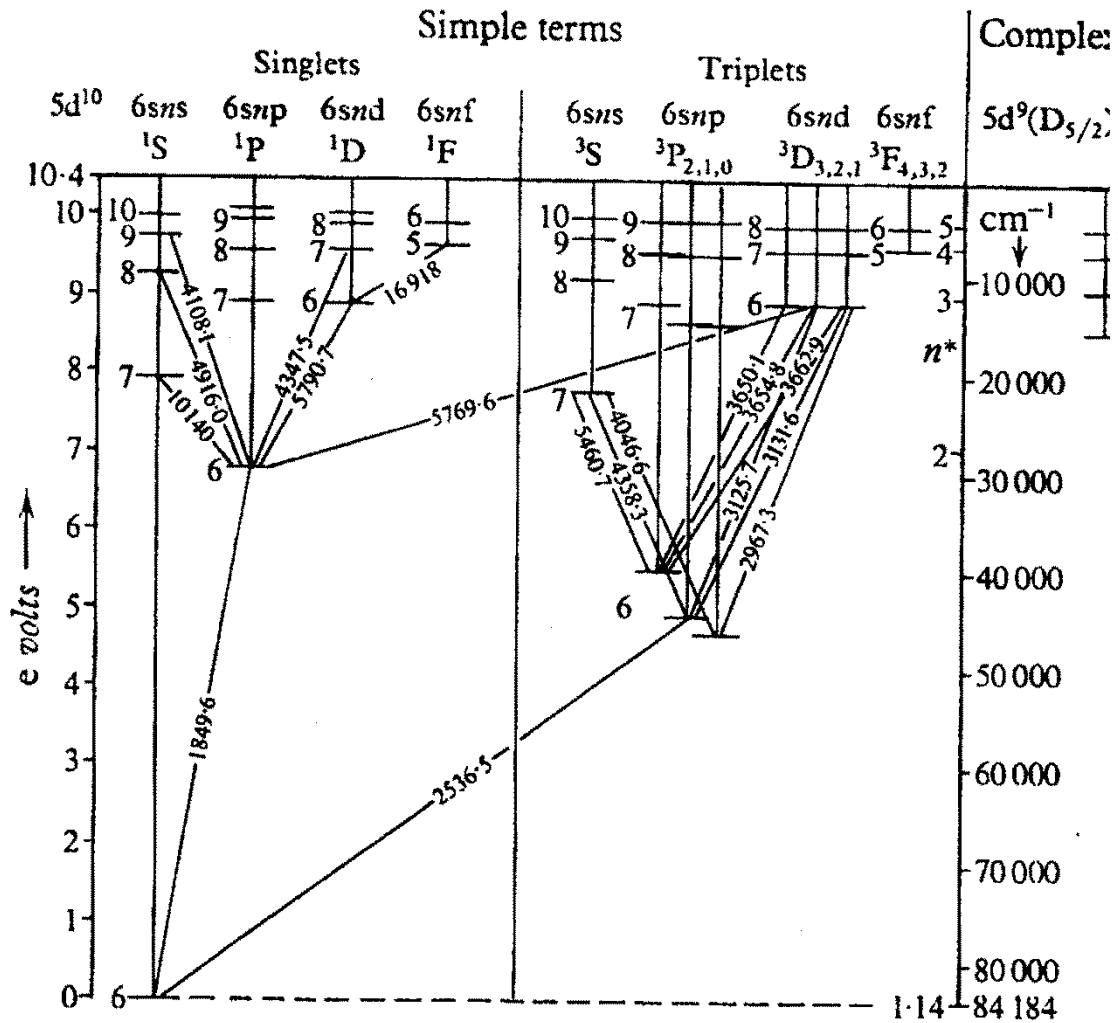

Figure 3-10 The term diagram of Hg. Diagram shows different excited states of Hg atoms and Hg spectral lines. Spectral lines are given in angstrom

The 184,9 nm line of Hg (Fig. 3-10) has very strong ($f_r > 1$) absorption oscillator strength which produces an unusually large broadening coefficient for the Hg6¹P₁ level. An accurate value of the Hg resonance transition probability, A_r , is needed to use resonance broadening for determining Hg densities in HP/HID arcs. Five published measurements of the vacuum lifetime of the Hg6¹P₁ level are: $1/A_r = 1,31 \pm 0,08$ ns (Lurio, 1965), $1,36 \pm 0,05$ ns (Lecler, 1968), $1,42 \pm 0,07$ ns (Gebhard & Behmenburg, 1975), $1,34 \pm 0,13$ ns (Abjean & Johannin-Gilles, 1976), $1,48 \pm 0,09$ ns (Bousquet & Bras, 1980). These five measurements have a total spread slightly greater than 10% with overlapping error bars. The paper from Menningen and Lawler (Menningen & Lawler, 2000) concludes that the most recent measurement from

Bousquest and Brass is the best and this value is adopted for calculations of the Hg density in this dissertation.

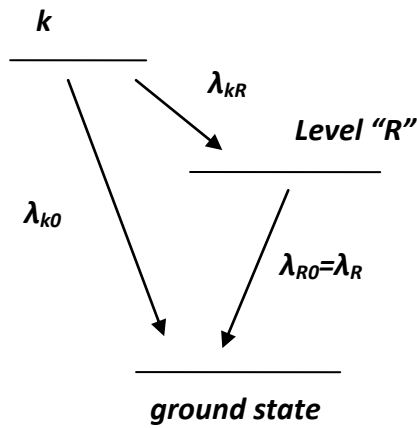

Figure 3-11 Spectral transitions under influence of resonance broadening

Formula for half width at half maximum (HWHM) derived in Griem (Ali & Griem, 1965):

$$\Delta\omega = 6,14 \cdot 10^{-14} \cdot \left(\frac{g_1}{g_R}\right)^{1/2} \lambda^2 \lambda_R f_R N \text{ (cm)}, \quad (3-59)$$

where *N* is the density of the ground state particles, *g*₁ is the statistical weight of the ground state, *g*_{*R*} and *f*_{*R*} are the statistical weight and oscillator strength of the resonance transition of the level "R". Level "R" is the upper or lower level of the observed transition, which happen to be the upper level of a resonance transition to the ground state. λ_R is the wavelength of the resonance transition.

The all possible line broadening mechanism must be addressed before using the width of the spectral line to determine the atom density. Resonance broadening is larger than Doppler broadening of these lines in HID arcs by a factor exceeding 100 (Lawler, 2004).

3.3.3. MEASUREMENT OF TEMPERATURE

Methods to determine the plasma temperature can be divided into two groups: methods based on the measurement of relative intensities of spectral lines and methods based on absolute intensity of spectral line.

If N identical atoms are in a cubic centimeter of a volume of plasma, a fraction of these atoms may be in excited state. In LTE, the fraction of N_i of these atoms with the energy E_i is described by the Boltzmann formula:

$$\frac{N_i}{N} = \frac{g_i}{U(T)} e^{-\frac{E_i}{kT}}, \quad (3-60)$$

where g_i is statistical weight of i^{th} level. The partition function $U(T)$ is given by:

$$U(T) = \sum_i g_i e^{-\frac{E_i}{kT}}. \quad (3-61)$$

One method to determine the plasma temperature by optical emission spectroscopy is based on the measurement of the relative intensities of two lines from the same element and ionization stage under the assumption that the Boltzmann equation is valid.

The intensity ration of two lines belonging to the same atomic species is given by:

$$\frac{I_1}{I_2} = \frac{A_1 g_1 \lambda_2 U_2 N_1}{A_2 g_2 \lambda_1 U_1 N_2} e^{-\frac{E_1 - E_2}{kT}}. \quad (3-62)$$

The index 1 refers to the first, and 2 to the second line. In case of two lines belong to the same ionization stage, two partition functions U_1 and U_2 are the same, likewise the number densities of particles in ground state $N_1 = N_2$, so that both cancel. The temperature can be evaluated without knowing the number density of atomic species from equation:

$$\frac{I_1}{I_2} = \frac{A_1 g_1 \lambda_2}{A_2 g_2 \lambda_1} e^{-\frac{E_1 - E_2}{kT}}. \quad (3-63)$$

The temperature resulting from Boltzmann equation has sometimes been called excitation temperature, but in LTE conditions it should be equal to the electron kinetic temperature. The Boltzmann two-line method has advantage of its simplicity, but the main disadvantage

of this method is that it may lead to considerable uncertainties of the determined temperatures. The relative error of the temperature, from the equation..., is obtained as:

$$\frac{\Delta T}{T} = \frac{kT}{E_2 - E_1} \frac{\Delta\left(\frac{I_1}{I_2}\right)}{\frac{I_1}{I_2}}. \quad (3-64)$$

The accuracy of the temperature measurement depends on the ratio $\frac{I_1}{I_2}$ and on the difference between energies of the upper energy levels. The accuracy of the measurement of the electron temperature is better if the difference between upper energy levels is large ($|E_2 - E_1| \gg kT$).

Accuracy of temperature determination from the Boltzmann equation may be improved by measuring a number of lines. The emission coefficients (absolute intensities) for a transition of a given emitting species can be expressed, using Boltzmann equation for population density, as:

$$\varepsilon_{ji} = \frac{hc}{4\pi\lambda} A_{ji} \frac{N}{U(T)} g_j e^{-\frac{E_j}{kT}}. \quad (3-65)$$

where λ is the transition wavelength, c is speed of light in vacuum. Taking the natural logarithm, the equation is transformed to:

$$\ln\left(\frac{\varepsilon_{ji}\lambda}{A_{ji}g_j}\right) = -\frac{1}{kT} E_j + \ln\left(\frac{hcN}{4\pi U(T)}\right). \quad (3-66)$$

If a graph is constructed for various lines with the left side of equation as the ordinate and the upper level energy E_j as the abscissa, data fit gives a straight line, whose slope yields the temperature:

$$\ln\left(\frac{\varepsilon_{ji}\lambda}{A_{ji}g_j}\right) = a \cdot E_j + b, \quad (3-67)$$

where $a = -\frac{1}{kT}$.

If the absolute intensities of the spectral lines are known, the temperature can be obtained from equation 3-65 as:

$$T = -\frac{E_j}{k} \cdot \frac{1}{\ln\left(\frac{4\pi\epsilon L}{h\nu A_{ji} g_j N}\right)} \quad (3-68)$$

3.3.4. CHARACTERIZATION IN NOT OPTICALLY THIN CONDITIONS (Lochte-Holtgreven, 1968)

The spectra of many high-density laboratory plasmas are characterized by the existence of self-reversed lines. Such plasmas usually do not allow temperature measurements by spectroscopic methods that neglect reabsorption within plasma column. The appropriate method is described by Bartels () and is called Bartels method. This method is based on the assumptions that the axially symmetric plasma is in local thermodynamic equilibrium (LTE), the equation of state for ideal gas fulfilled, the partial pressure of the emitting atoms constant throughout the plasma column, and that the depletion of the ground state population due to excitation and ionization can be neglected.

The intensity of a spectral line within Bartels' method is given by:

$$I_\nu = \frac{2h\nu^3}{c^2} e^{-\frac{h\nu}{kT_m}} M Y(\tau_0(\nu), p),$$

where $\tau_0(\nu)$ is the optical depth, and the function $Y(\tau_0(\nu), p)$ represents the influence of the optical depth on the peak line intensity (could be expressed parametrically). The parameters M and p describe the inhomogeneity of the plasmas, so that $p = 1$ corresponds to a homogeneous plasma column, and $p = 0$ to a completely inhomogeneous source.

In figure 3-12 a) the optical thickness $\tau_0(\Delta\nu)$ is plotted over the $\Delta\nu$ scale for five cases of different optical depths in the line center. The line shape is kept constant. Part b) of the figure 3-12 gives the function $Y(\tau_0(\nu), p)$ over the same τ_0 scale. Part c) of the figure 3-12 gives the resulting intensity distributions $I_\nu(\nu)$. Curve 1 represents the optically thin case and gives the undistorted distribution $\tau_0(\Delta\nu)$. In case 2, the line center is no longer optically thin because the intensity increase in line center is smaller than in the wings where the intensity is still proportional to τ_0 . In example 3, the deviations of $I_\nu(\nu)$ from $\tau_0(\Delta\nu)$ are even more pronounced. The optical thickness in the line center has just that value $\hat{\tau}_0$ that

belong to maximum of the function $Y(\tau_0(\nu), p)$. The line center is flattened and the intensity has reached the maximum value possible under the conditions considered. Further enlargement of optical thickness increases the intensity only in the wings. In the regions around the line center intensity decreases although $\tau_0(\Delta\nu)$ increases because here the negative slope of Y – curve comes into action. The line becomes self-reversed (line 4).

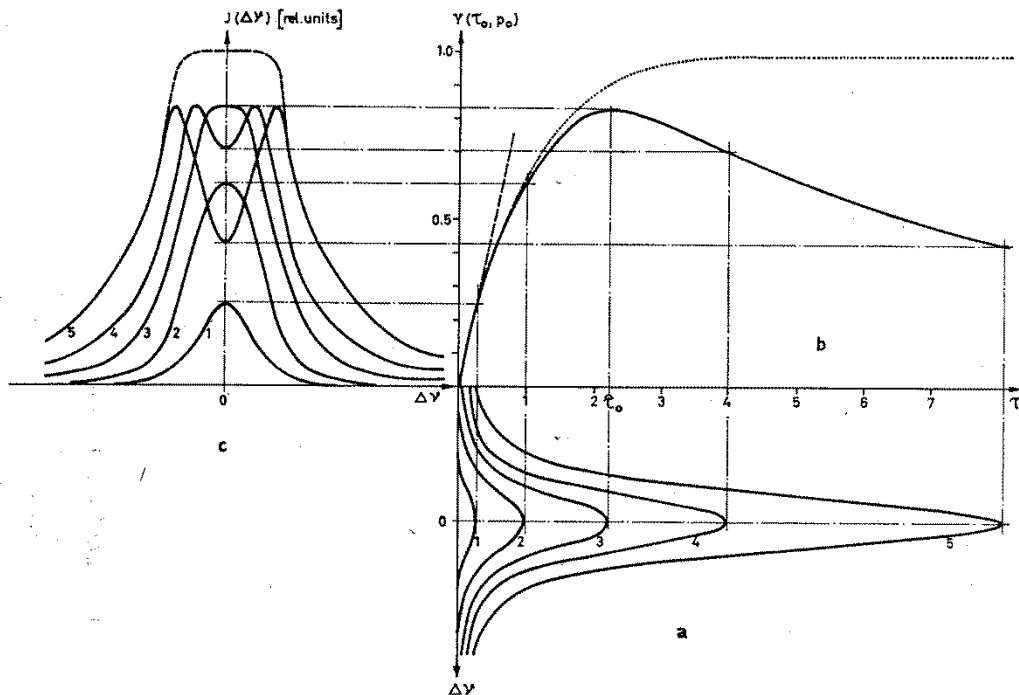

Figure 3-10 Distortion of the intensity distribution due to reabsorption: a) Distribution of optical thickness within the line $\tau_0(\Delta\nu)$, b) The function $Y(\tau_0(\nu), p)$, c) Resulting intensity distribution

4. CHARACTERISTICS OF HIGH PRESSURE INDIUM MERCURY METAL HALIDE DISCHARGE

High-pressure discharge lamps with metal halide additives have become increasingly interesting as compact high intensity light sources with high luminous efficacy and good color rendering properties (Stromberg, 1979). A theoretical description of such discharges is complicated, because the discharge plasma consists of a large number of different molecular, atomic and ionic species, which react with each other.

4.1. HIGH INTENSITY METAL HALIDE DISCHARGES (Osram)

In discharge lamps, light is generated by a gas discharge of particles created between two hermetically sealed electrodes in an arc tube. After ignition, the particles in the arc are partially ionized, making them electrically conductive, and “plasma” is created. In high intensity discharge lamps, the arc tube is usually enclosed in an evacuated outer bulb which isolates the hot arc tube thermally from the surroundings, similar to the principle of a thermos flask. But there are also some discharge lamps without outer bulbs, as well as lamps with gas-filled outer bulbs. In contrast to low-pressure discharge, there is high pressure and a high temperature in a discharge tube.

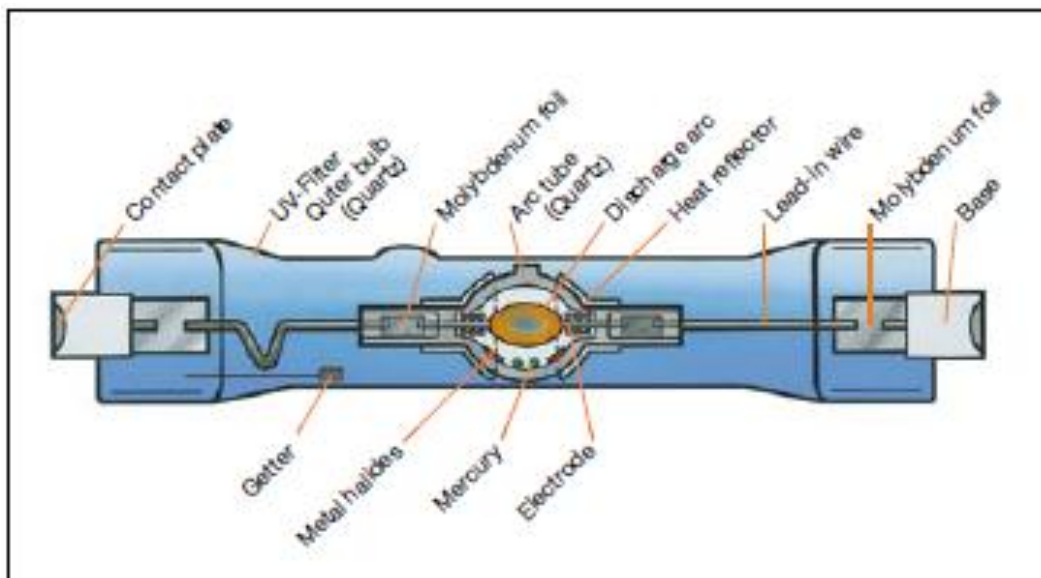

Figure 4-1 An example of how a metal halide lamp works based on a double-ended lamp with a quartz arc tube.

In an arc tube, gas discharge works through excitation of the luminous additives (metal halide salts) and the mercury is excited by the current flow (Fig. 4-2). Visible radiation characteristic for the respective elements is emitted. The mixture of the visible radiation of the different elements results in the designed color temperature and color rendering for a particular lamp. In the operating state, the mercury evaporates completely. The other elements involved are present in saturated form at the given temperatures, i.e. they only evaporate in part; the rest is in liquid form at the coolest point in the arc tube. The fraction of the filling that has evaporated depends on the temperature of the coolest point on the arc tube wall and also varies for the different filling components. Changes to the temperature of the arc tube wall can change the composition of the metal halides in the discharge, thus also changing the color properties of the lamp.

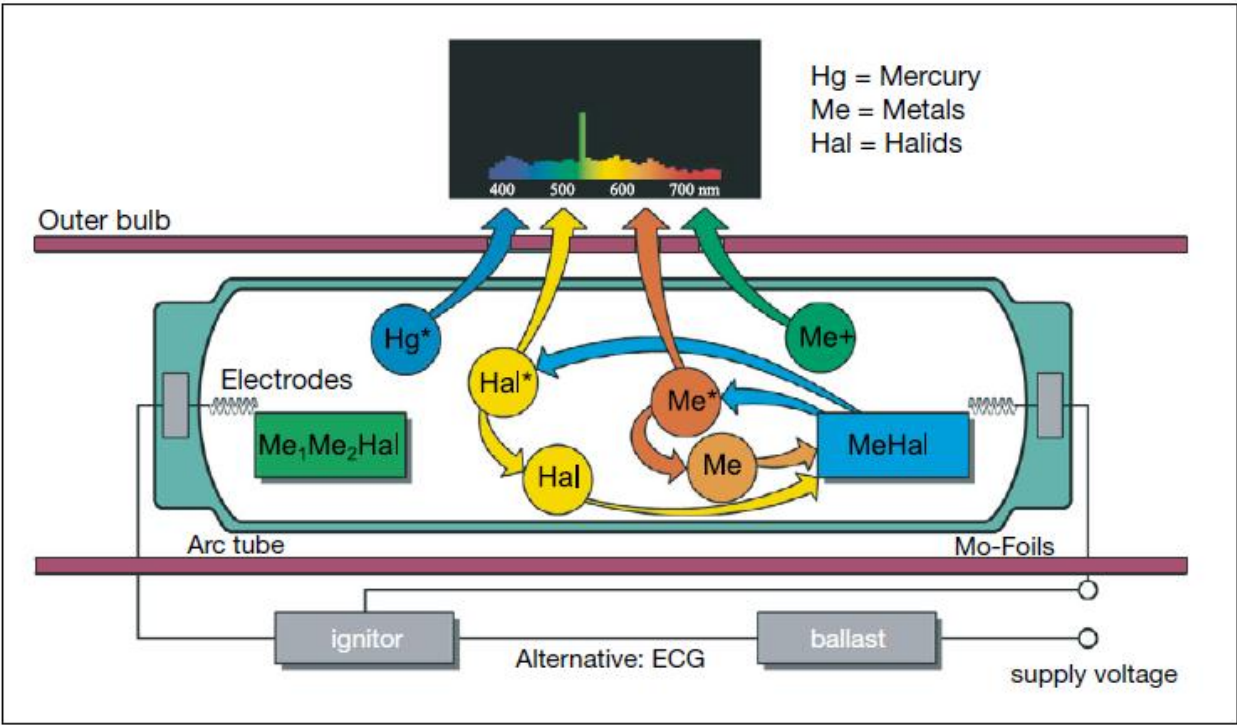

Figure 4-2 Chemistry of the HID

Discharge tubes can be divided on 1st-generation metal halide lamps and 2nd-generation metal halide lamps.

The discharge tubes in 1st-generation metal halide lamps are made of high purity quartz glass. This quartz material allows for stable operation at high temperatures, is resistant to sudden changes in temperature and is transparent. They are made in cylindrical form. Second generation metal halide lamps were made of freely moldable ceramic that made it possible to produce round ceramic arc tubes with a constant wall thickness.

4.2. IGNITING AND STARTING DISCHARGE LAMPS

Since the discharge reacts to increasing lamp current with falling voltage (which would cause the current to rise indefinitely until the fuse blows or another part of the circuit fails), the lamp current must be limited by ballast during operation. This usually consists of an inductive circuit (choke), although in rare cases up to 400 W capacitive circuits are also possible. In most cases, additionally to the current-limiting element, an ignition device is needed to start discharge. Some discharge lamps do not require an external ignition unit, as the supply voltage is sufficient to ignite the lamp or because the lamp has an integrated ignition unit.

At room temperature, the filling particles are still present in solid form (metal halides or amalgam) or in liquid form (mercury). The arc tube contains the start gas, usually an inert gas such as argon or xenon. The insulating gas filling in the arc tube must be made conductive in order to generate hot plasma. This is carried out by high-voltage pulses generated by an ignition unit. Constantly available free charge carriers (electrons) are accelerated by high voltage, providing them with sufficient energy to ionize atoms on impact and generate more free charge carriers. This process, similar to an avalanche, finally produces conductive hot plasma within which the current flow excites the partly evaporated metal halide filling such that light is radiated. The ignition voltage (4 – 5 kV) required to generate a breakdown between the electrodes depends on the spacing between the electrodes, the filling pressure of the gas between the electrodes and the type of gas.

After igniting the lamp and heating the discharge, the discharge runs initially only in the start gas. The mercury and the metal halides are still in liquid or solid form on the arc tube wall. The voltage across the discharge is initially still very low. The start gas radiates a little in the visible range, which is why the luminous flux in the initial phase is still very low. Through

power consumption in the lamp, first the mercury and then also the metal halides begin to evaporate. The individual filling particles evaporate at different rates, resulting in differing ratios of the particles during run-up. The dominance of individual particles in the start-up phase results in the color phenomena during this period shown in Figure 4-3. Only after a few minutes, having reached the steady state, is the required composition achieved, producing the full luminous flux and the required light color.

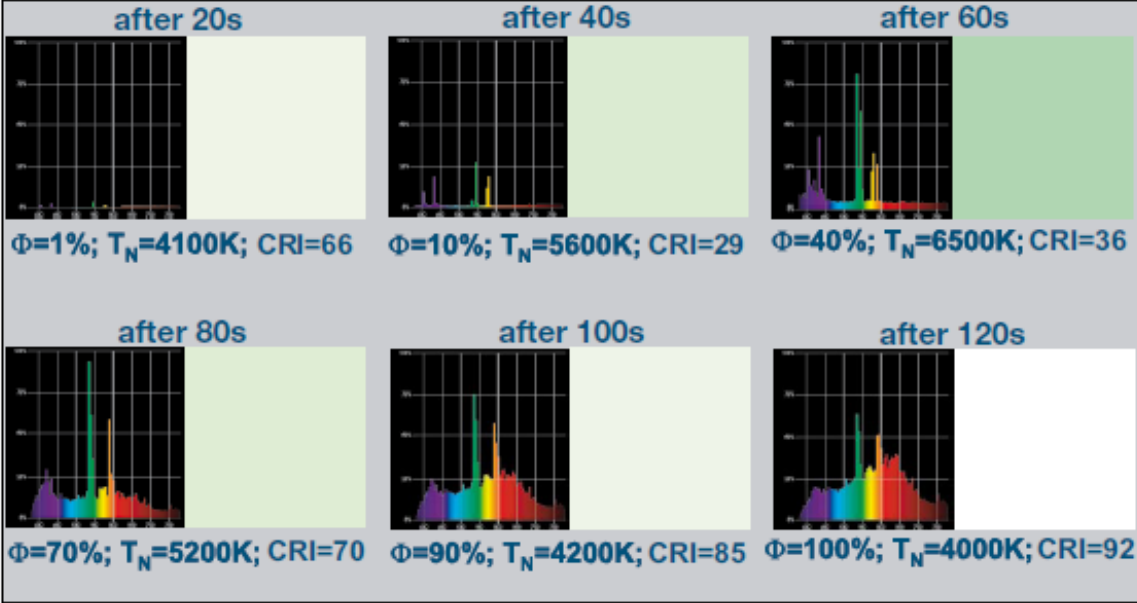

Figure 4-3 Course of light parameters during start-up

4.3. HIGH-PRESSURE DISCHARGE WITH MERCURY AND INDIUM

The measurements have been performed using 400 W HgIn discharges. The lamp used in the research was HQI-T 400 BLUE (“Osram”). The arc tube has a quartz body with a maximum inner diameter of approximately 18 mm and outer diameter of 20 mm. The tips of the electrodes are separated 50 mm. The internal geometry of the lamp is cylindrically symmetric (Fig. 4-4)



Figure 4-4 An example of HQI-T 400 BLUE lamp

The arc tube was dosed with Hg, metal halide salts and inert gas. The Hg dose is 53 mg. The discharge was operated vertically, driven by a standard 50 Hz AC line source, with a discharge current between 3,5 A and 3,6 A.

In figure 4-5 the spectrum of In Hg discharge, recorded with the solid state spectrometer is shown.

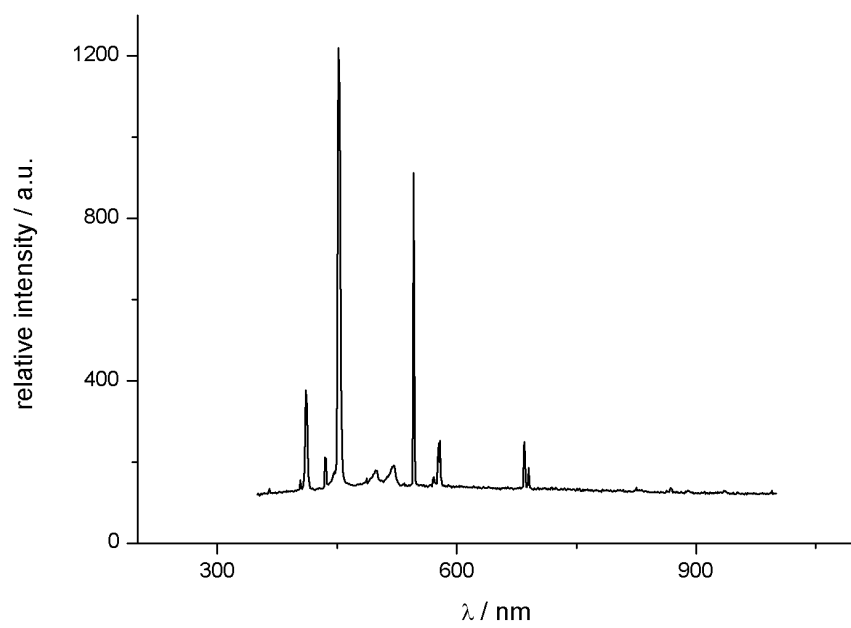

Figure 4-5 Spectrum of HgIn discharge

5. DETERMINATION OF PARAMETERS OF MERCURY – INDIUM PLASMA

5.1. EXPERIMENTAL SETUP

Measurements were performed using two basic experimental setups: one for the time averaged measurements (without Boxcar Averager – Figure 5-1) and the other for the time resolved measurement (with Boxcar Averager – Figure 5-2). The arrangement is almost the same for both types of the measurements; the difference is in the signal processing.

Experimental setup for time averaged measurements (Figure 5-1) consists of high pressure metal halide discharge, low pressure discharge, two lenses with the same focal length of 15 cm, spherical mirror, folding mirror, monochromator, photomultiplier, linear amplifier, A/D converter and the computer. Experimental setup for time resolved measurement in addition consists of Boxcar Averager, oscilloscope and a photodiode (Figure 5-2).

Light from the high pressure gas discharge is focused with the lens on the entrance slit (slit width was 10 μm) of the monochromator. The magnification of the optical system is 3:1. The lens L_2 is mounted on a translator. It can be moved laterally so that different sections of the plasma column can be focused on the entrance. In this way it is possible to measure the spatial distribution of radiation in the direction perpendicular to the optical axis.

Spherical mirror is placed on the other side of the high pressure discharge and its role is described in Chapter 3.

Two different monochromators were used: SPM2 (Spiegel Plangitter Monochromator model 2 with an EMI 9534B photomultiplier) for lines in visible part of the spectrum and ACTON (Acton Res. Inc., model SP2750 with a photomultiplier Hamamatsu R406) for infrared part of the spectrum. Using the photomultiplier light signals are converted to current signal that is detected and analyzed.

Processing electronics differs for time averaged measurements and for time-resolved measurements. In time averaged measurements, signal that leaves the photomultiplier

enters current-voltage (U/I) converter and is sent to A/D converter and recorded in the computer (Figure 5-1).

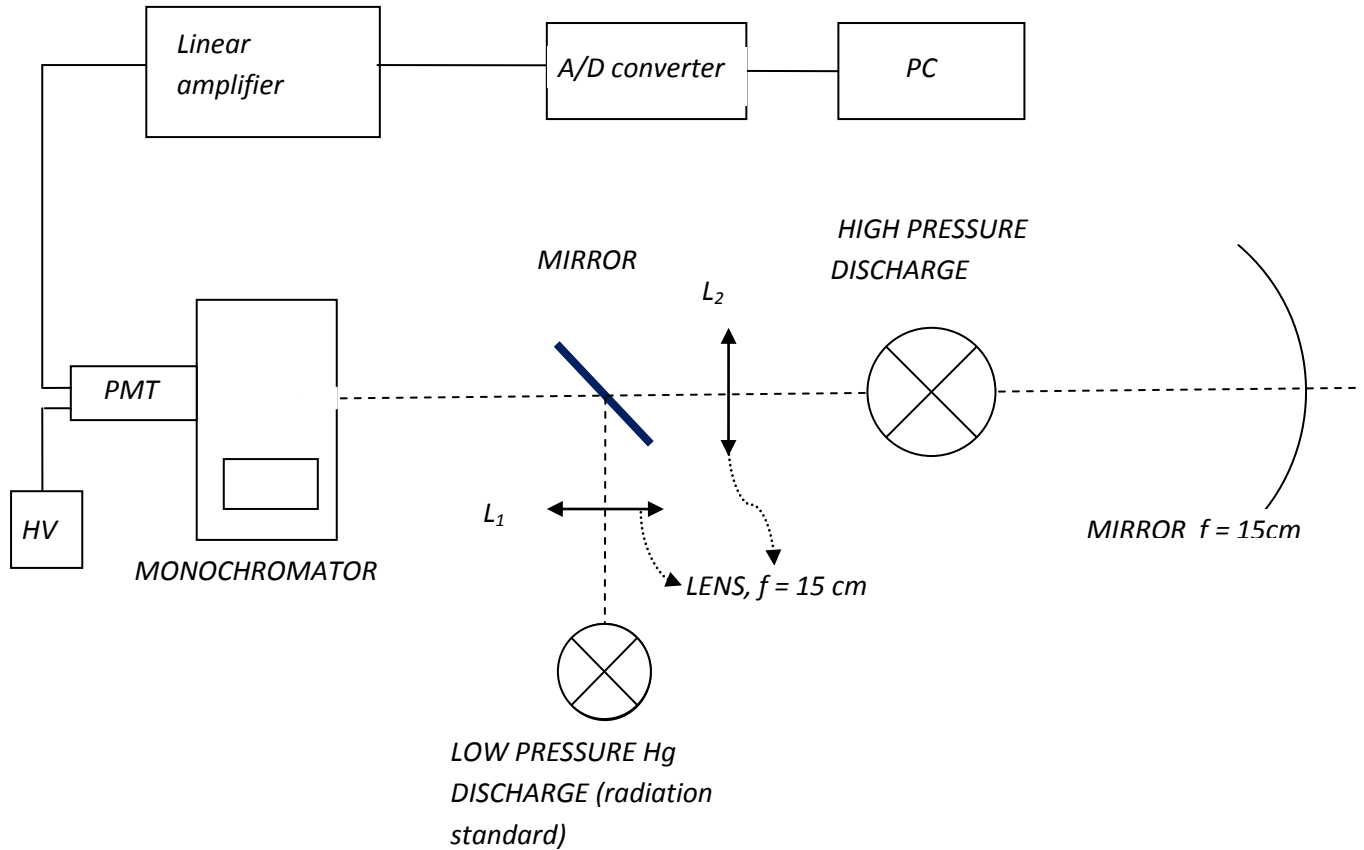

Figure 5-1 Experimental setup for time averaged measurements: Experimental setup consists of high pressure metal halide discharge, low pressure discharge, two lenses with the same focal length of 15 cm, spherical mirror, folding mirror, monochromator, photomultiplier, linear amplifier, A/D converter and the computer

Figure 5-2 shows the experimental setup for time-resolved measurements that were used to examine how plasma parameters change with the phase of AC current. For this purpose the Boxcar averager was used and thus the part of the experimental setup dealing with signal processing is different from one for time-averaged measurements. The signal from the linear amplifier is processed with the Boxcar averager. The boxcar averager collects only the electrical signals with the same phase of AC current in a way that it collects the signals that come only during the aperture duration (Figure 5-3). Relative position of the boxcar aperture relative to trigger and aperture duration can be adjusted. The relative position of the

aperture is the time that passes from triggering. Trigger signal for triggering comes from the photodiode and has the sinusoidal form.

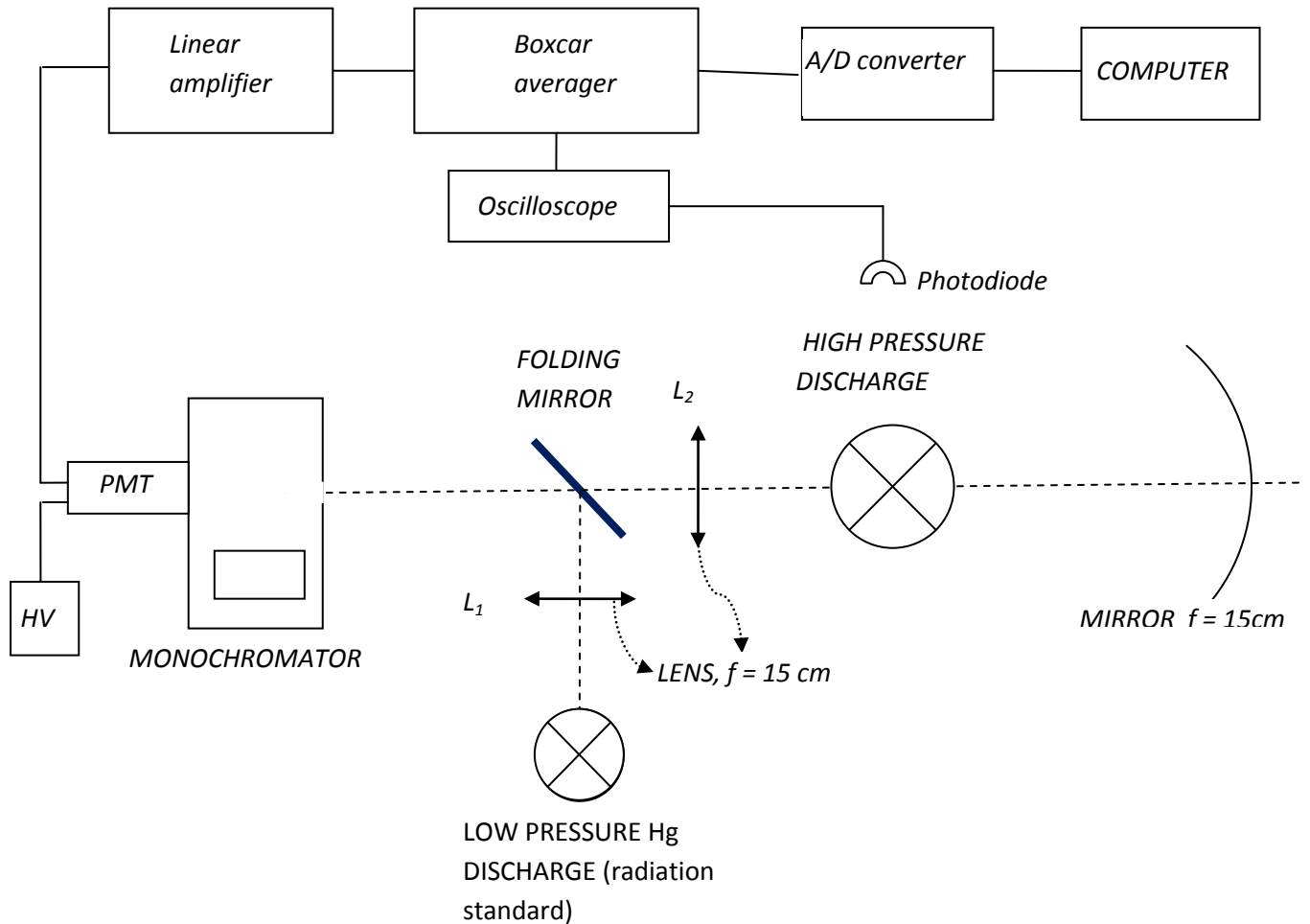

Figure 5-2 Experimental setup for time resolved measurements: experimental setup consists of high pressure metal halide discharge, low pressure discharge, two lenses with the same focal length of 15 cm, spherical mirror, folding mirror, monochromator, photomultiplier, Boxcar averager, oscilloscope and photodiode

Figure 5-3 shows the schematics of the external or the line triggering for the time resolved measurements, provided by boxcar averager. The first graph shows the AC driving current of the lamp. On the second graph the photodiode signal is represented and the third graph shows one complete period of lamp current and position of aperture delay and duration time. Shape of the signal from photodiode is modeled with absolute value of the sine function because the plasma is equally excited for maximum positive and maximum negative AC current value. Triggering happens when the trigger signal is at minimum. With

appropriate choice of aperture duration and delay, time dependant behavior of the spectrum is observed. This technique enables sampling out the spectrum of plasma radiation at any desirable phase of the AC current. In this experiment we performed all the measurements using the aperture duration time of $500 \mu\text{s}$, with different aperture delay times. Measurements were performed for different phases of the AC current.

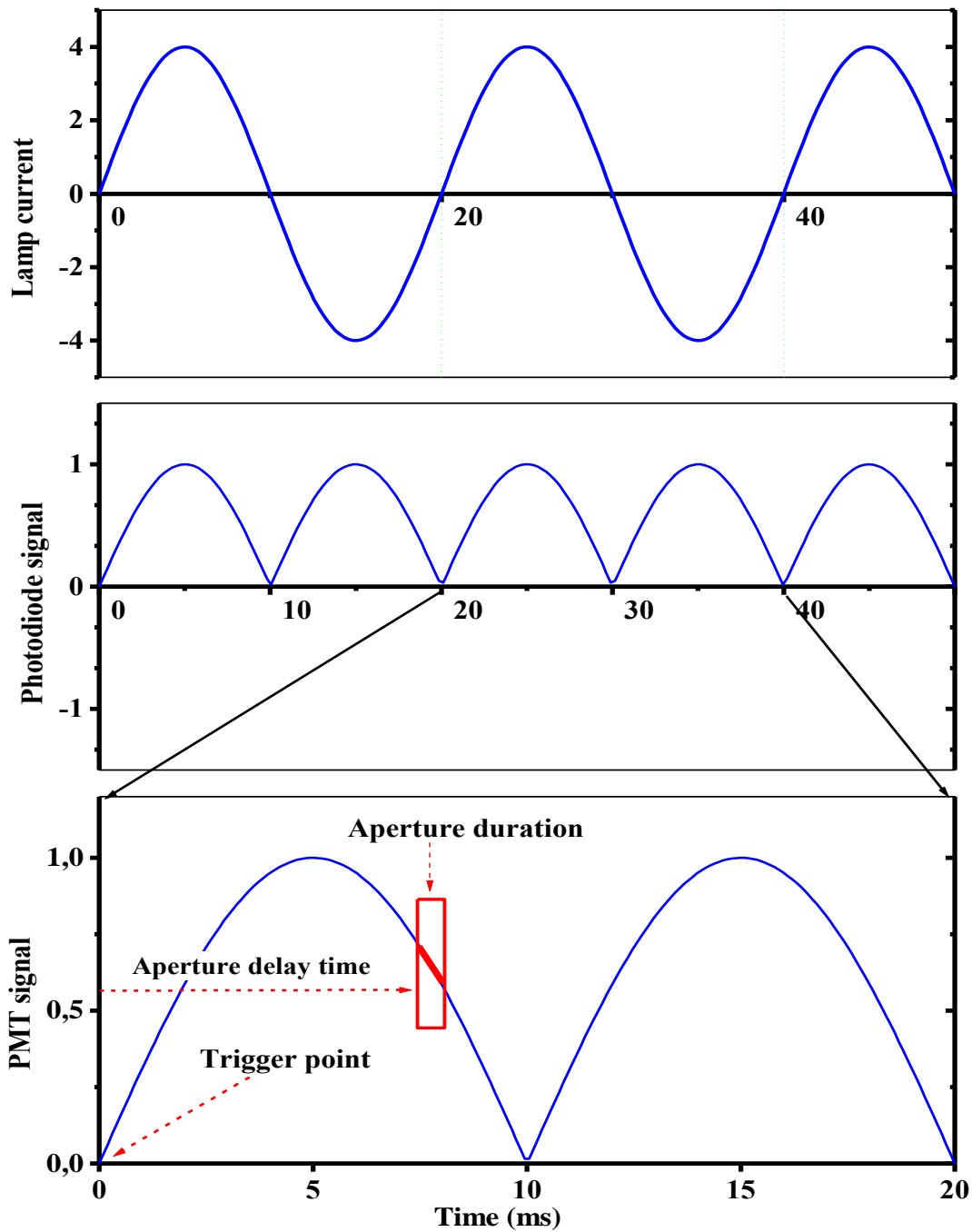

Figure 5-3 Line triggering for time resolved measurements. The upper part displays the AC discharge current, the middle part – the corresponding time dependence of the photomultiplier signal, and the lower part – a general case of timing for data acquisition.

5.2. CHARACTERISTICS OF MONOCHROMATOR

5.2.1. DETERMINATION OF THE WAVELENGTH CALIBRATION SCALE

The scale of SPM monochromator contains relative wavelength units of observed spectral lines. Thus, to each relative wavelength unit, the exact wavelength need to be associated, i.e. the calibration function of monochromator needs to be determined.

Known wavelengths from characteristic spectral lines from different low-pressure spectral lamps were associated to relative wavelengths from the monochromator scale and represented with one dot in the graph (Figure 5-4). The data in the graph were fitted with the linear function which best approximate the measured data. From this graph it is later possible to determine the real wavelength of the observed spectral line whose relative wavelength is read on the monochromator scale.

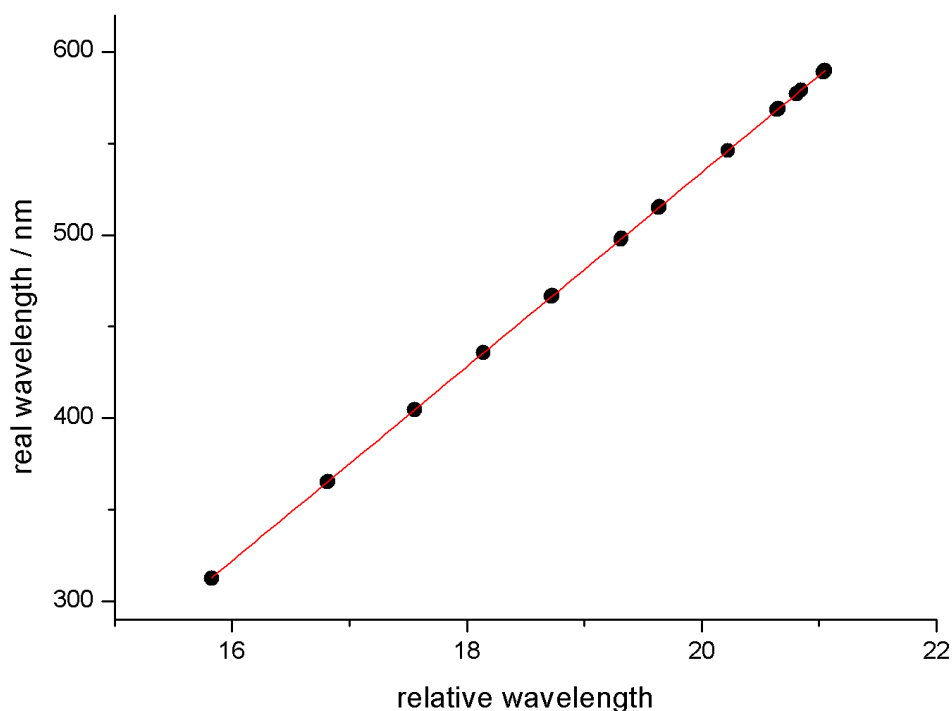

Figure 5-4 Calibration of the relative wavelength scale of SPM2 monochromator

The linear function above is described with linear equation:

$$\lambda_{real} = a \cdot \lambda_{rel} + b, \quad (5-1)$$

where a and b are parameters given in table.

Table 5-1 Parameters of linear function that connects real and relative wavelengths

	Average value	Standard error	Relative error
a	53,01495	0,02564	0,05%
b	-526,08903	0,49419	0,09%

5.2.2. INSTRUMENTAL FUNTION OF THE MONOCHROMATOR

The width and shape of the spectral lines is influenced by the measuring device used for their detection. Even if a truly monochromatic light falls on the entrance slit of monochromator (best example is the laser light), it spreads out the line and it is not observed as monochromatic any more. The spectral line will have finite width and shape called instrumental function of the monochromator.

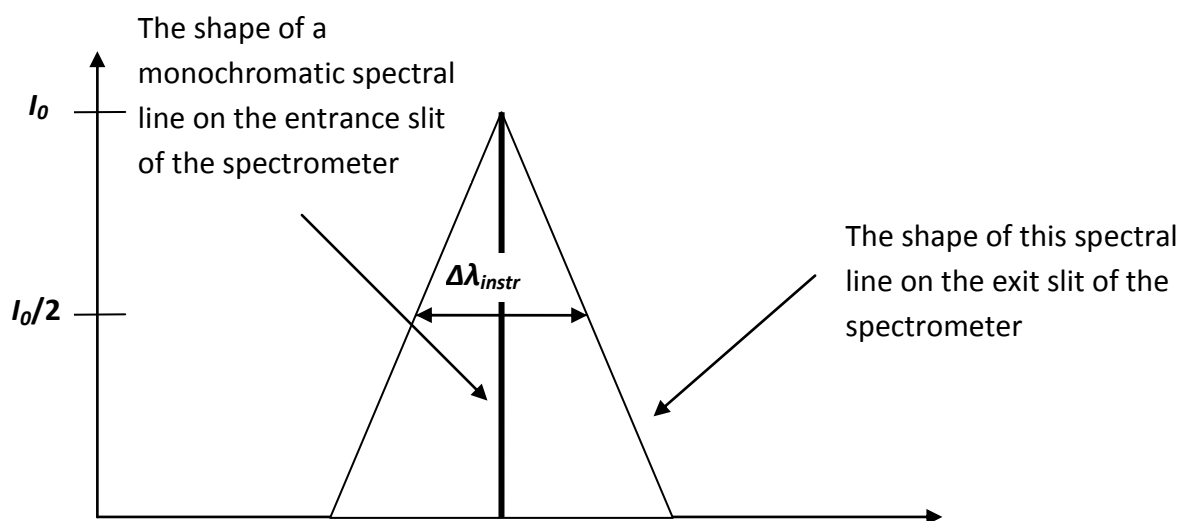

Figure 5-5 The influence of monochromator on the width and shape of spectral lines

Instrumental function is determined by the finite width of the entrance and exit slit, the optical grating that determines the resolving power of the instrument and the imperfections of the measuring device. For very narrow slit the instrumental function is described with Fraunhofer diffraction and for wider slits it will be represented with the triangular function. As we make the both slits narrower, the triangular shape of the spectral line looks more and more like to Gauss than to Lorentz profile.

The instrumental function of the monochromator has the relevant impact on the overall shape of the measured spectral line. For this reason it is important to find the optimal width of the entrance and exit slit of the monochromator which will ensure the best signal to noise ratio and the minimal width of the instrumental function.

The instrumental function of monochromator is usually determined by shining the entrance slit of monochromator with the radiation that corresponds to spectral line which width is almost negligible. In that case only the monochromator determines the observed shape of the spectral line. The light from He-Ne laser was often used as the source for determining instrumental function. The instrumental profile of measured spectral lines was best represented with Gauss function, whose width corresponds to width of instrumental function (Figure 5-6).

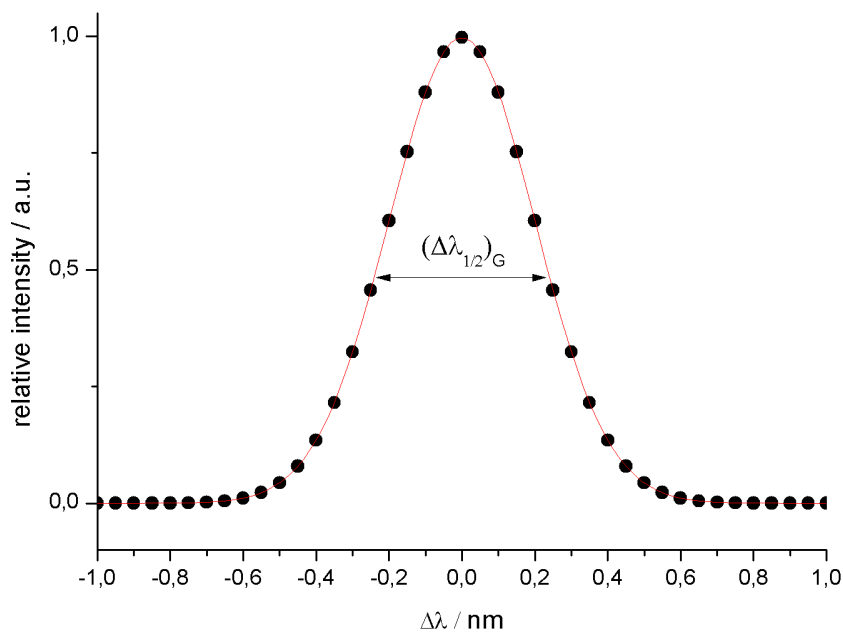

Figure 5-6 Instrumental function of monochromator. $(\Delta\lambda_{1/2})_G$ is the width of the instrumental function of the monochromator. Dots represent the measured points and red curve Gauss fit

Figures 5-7 and 5-8 show the dependence of the width of the Gauss profile on the width of the slit for SPM and ACTON monochromators.

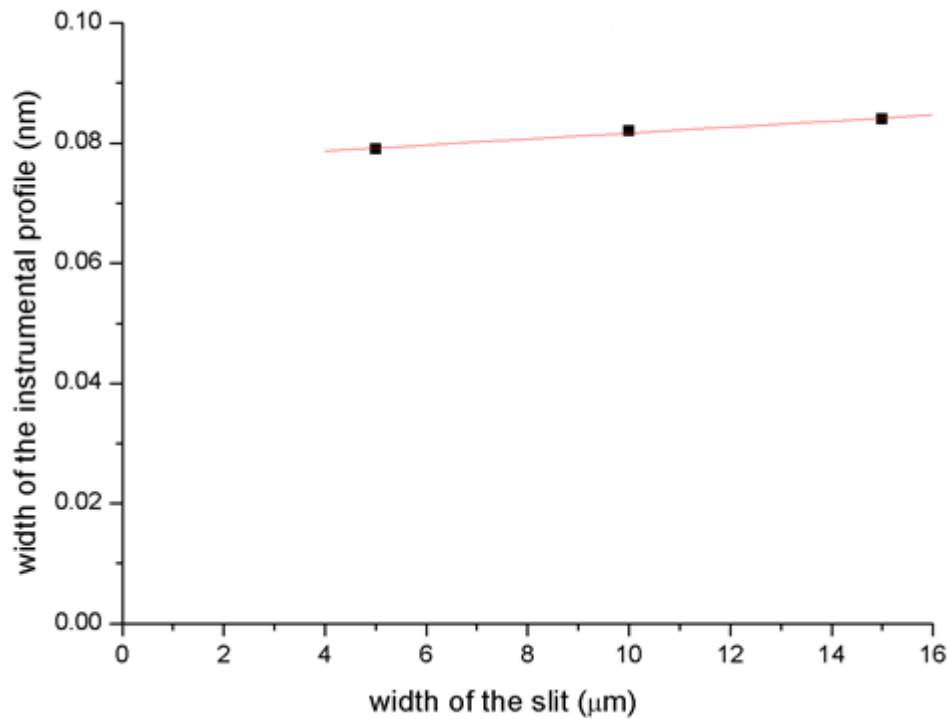

Figure 5-7 Dependence of instrumental function $(\Delta\lambda_{1/2})_G$ of SPM monochromator on the width of the monochromator slit

From figure 5-8 it is observed that for wider slits the width of the instrumental function of the monochromator shows the linear dependence on the width of the monochromator slit. For smaller slit widths the width of the instrumental function of the monochromator does not change slower for the different widths of the slit, and for slits smaller of 10 μm it is approximately constant.

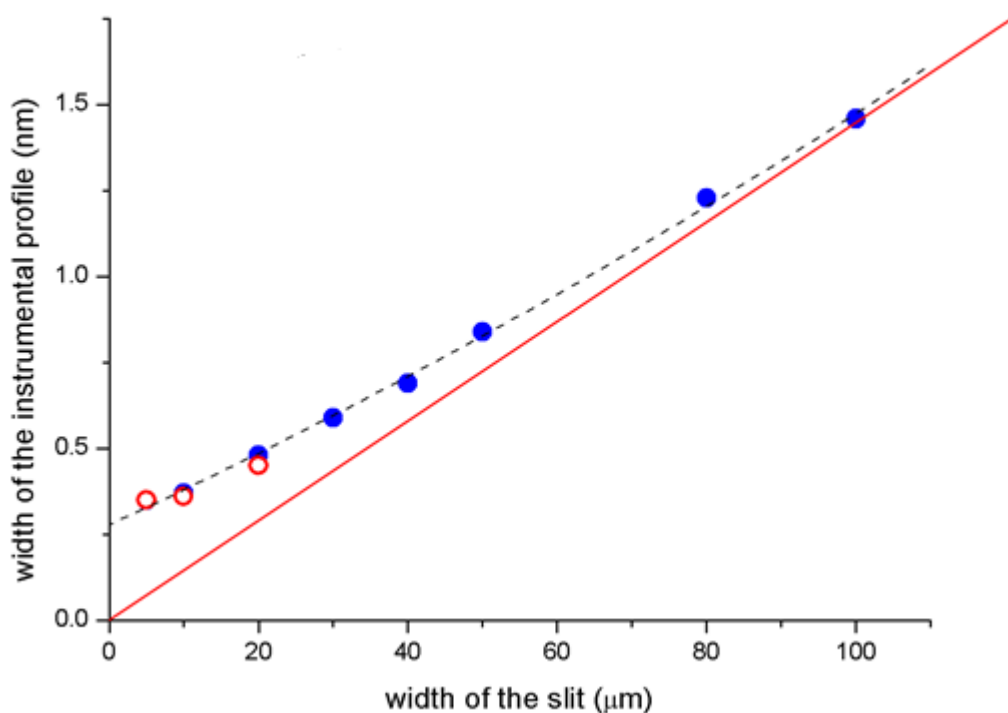

Figure 5-8 Dependence of instrumental function ($\Delta\lambda_{1/2}$) of ACTON monochromator on the width of the monochromator slit. Red line represents the linear fit and the dashed line represents polynomial fit

5.2.3. COMPARISON OF INTENSITIES OF HIGH AND LOW PRESSURE GAS DISCHARGES

One of the problems with any lamp using mercury, as well as with other gas discharge lamps is the variation of irradiance with lamp current and environmental changes such as temperature and air flow. Line intensities coming from high pressure Hg In discharge are measured in relative units. To obtain absolute values, measured radiation needs to be compared with standard source of radiation. Radiation standard is an ultraviolet lamp whose irradiance can be established as stable over a large current range and whose construction makes it a convenient laboratory instrument. The low-pressure Hg discharge source (mercury pencil lamp) was used for this comparison (Childs, 1962). It consists of a small U-shaped quartz tube filled with natural Hg and Ar carrier gas, is operated in ac mode on a low current. Approximately length and diameter of the tube are 52 mm and 6,5 mm, respectively. Absolute irradiance from the lamp (at distance of 1 m) for 577 nm line is known, and it equals $6,63 \cdot 10^{-9} \text{W/cm}^2$.

For accurate comparison of two sources of light, optics that focuses the sources on the entrance slit must be adjusted that the radiation from the same areas and spatial angles is measured. That was done by using two completely identical lenses, L_1 and L_2 (Figure 5-1). The low pressure mercury pencil lamp was placed on the same distance from the lens L_1 , as the high pressure lamp for lens L_2 and the folding mirror was used (Figure 5-1). The factor of reflection of the mirror (FM on Figure 5-1) was also measured to evaluate the possible losses on the mirror. It was found that the mirror reflects 97% of the incident light. This loss is taken into account when calculating absolute intensities.

Lines 577 nm and 579 nm of the both high pressure and low pressure discharge were recorded using monochromator SPM2 (the slit width was 10 μm).

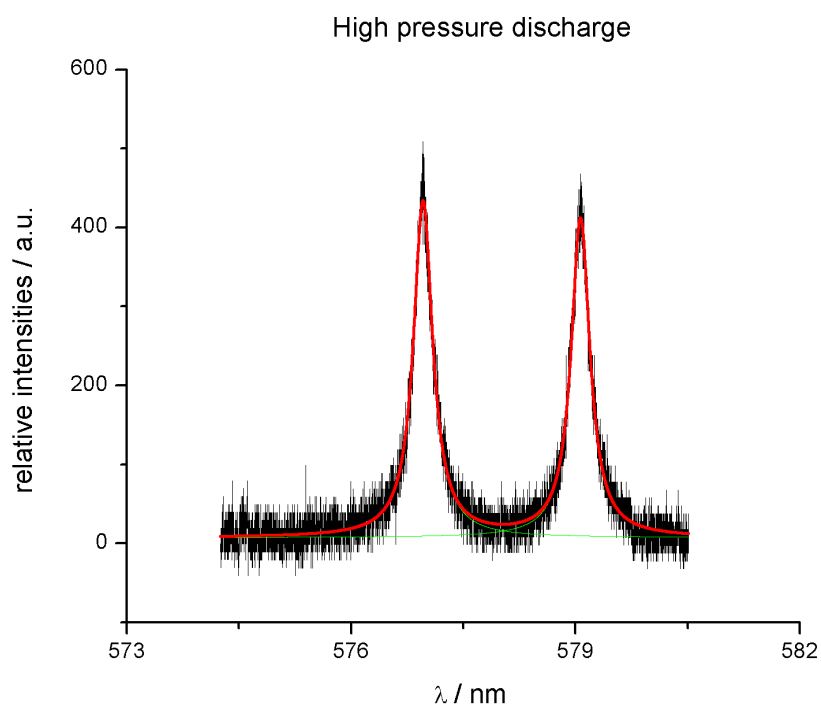

Figure 5-9 Lines 577nm and 579 nm from high pressure discharge

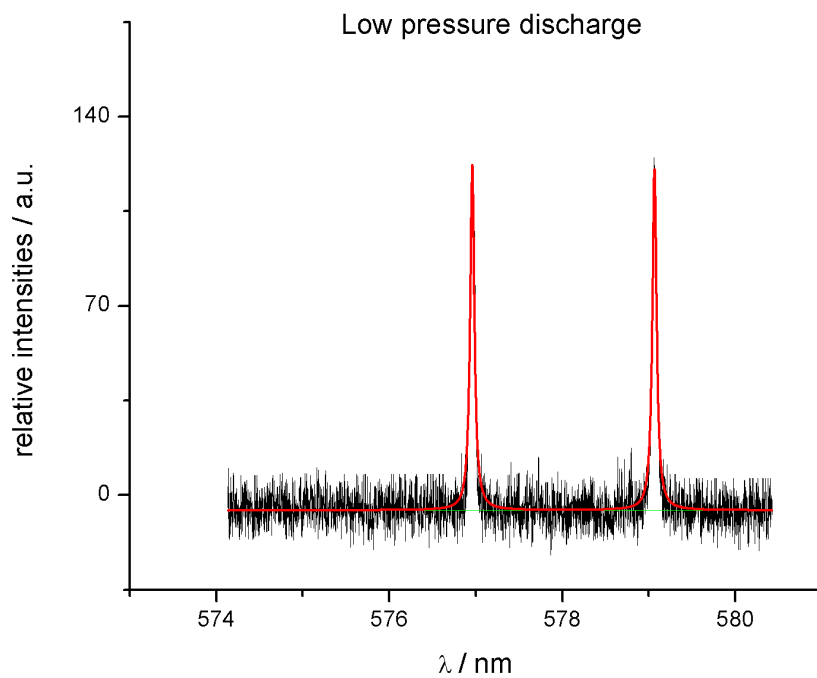

Figure 5-10 Lines 577nm and 579 nm from low pressure discharge

Lines from both high and low pressure discharge lamps were analyzed and the areas under the peaks were calculated. These areas represent relative line intensities and their ratio gives comparison of the intensities emitted by the high and low pressure discharge lamps. For the spectral line 577 nm this ratio equals 17,8.

One subsequent measurement was done with wide slit and intensities for low and high pressure discharge were recorded. In this measurement, the entrance slit had the width of 10 μm , while the exit slit was made wide, with the width of about 1 mm.

Figures below show the intensities for that case.

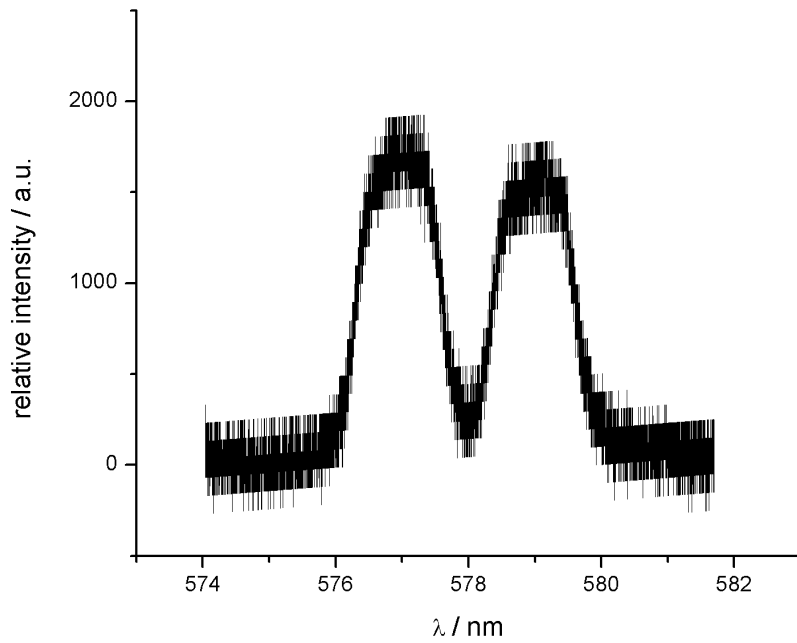

Figure 5-11 Relative intensities of 577nm and 579 nm lines in high pressure discharge

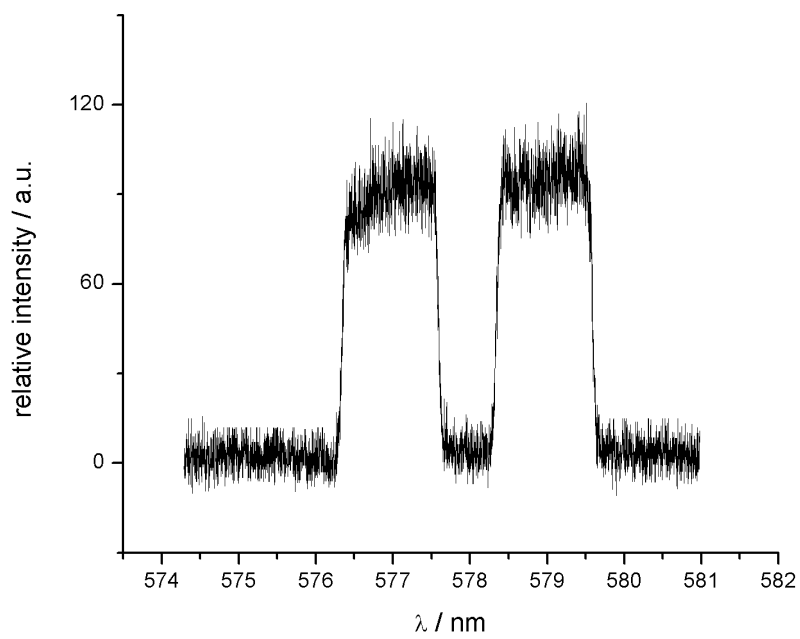

Figure 5-12 Relative intensities of 577nm and 579 nm lines in low pressure discharge

Ratio of the intensities between high and low pressure discharge lamps equals 17.

Now, when the ratio of the intensities between high and low pressure discharge lamps is calibrated, the absolute intensity of the high pressure discharge lamp can be calculated as:

$$I_{HP}^{ABS} = I_{LP}^{ABS} \cdot \frac{I_{HP}^{rel}}{I_{LP}^{rel}} \quad (5-2)$$

As written before, the absolute intensity for the low pressure mercury discharge lamp, which is taken as the standard of radiation, is known. For line 577 nm at the distance of 1 m from the source it equals: $6,63 \cdot 10^{-9} W/cm^2$. In our case the lamp was placed 20 cm from the lens that images its light on the entrance slit. The ratio of the intensities at two different distances from the source equals:

$$\frac{I(d_1)}{I(d_2)} = \frac{d_2^2}{d_1^2} \quad (5-3)$$

where d_1 and d_2 are the distances from the source. Thus, the irradiance at distance 20 cm from the source equals $1,66 \cdot 10^{-7} W/cm^2$.

Next the radiant energy within the solid angle is calculated. Solid angle is defined as:

$$\Omega(sr) = \frac{A}{R^2} \quad (5-4)$$

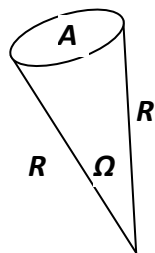

Figure 5-13 The area $A = 2,27 \text{ cm}^2$ and radius $R = 20 \text{ cm}$

Solid angle equals $5,67 \cdot 10^{-3} sr$ and intensity within this solid angle of $2,92 \cdot 10^{-5} W/cm^2 sr$.

Now the absolute radiance of the high pressure discharge lamp, for line 577 nm equals $4,97 \cdot 10^{-4} W/cm^2 sr$.

5.2.4. EXPERIMENTAL CHECK IF LINE 577NM IS OPTICALLY THIN

The most widely used methods for determining the plasma parameters are based on optically thin spectral lines and thus we need to check if used spectral lines are optically thin. As described in Chapter 3.2, this can be done with the use of duplicating mirror that generates the image of the plasma column at the place of original plasma.

Using the experimental setup shown in Figure 3-8 the 577nm line is recorded with and without the use of duplicating mirror. The line profiles are shown in Figure 5-11.

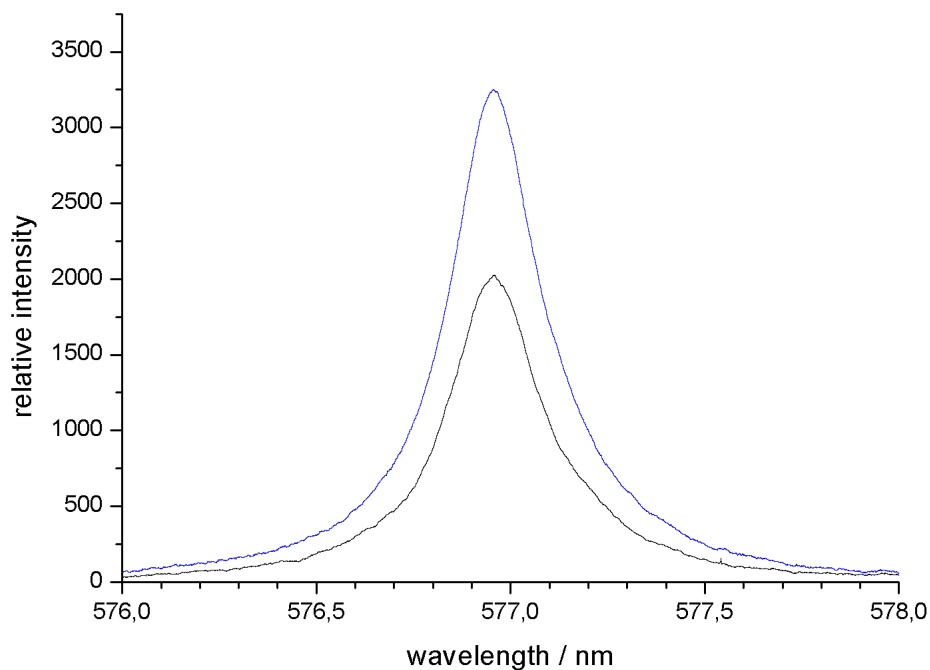

Figure 5-14 Line profiles of 577 nm line with and without duplicating mirror (see Figure 3-8)

Relative intensities of the same spectral line recorded with and without the mirror were divided and the ratio of the intensities is shown in Figure 5-15.

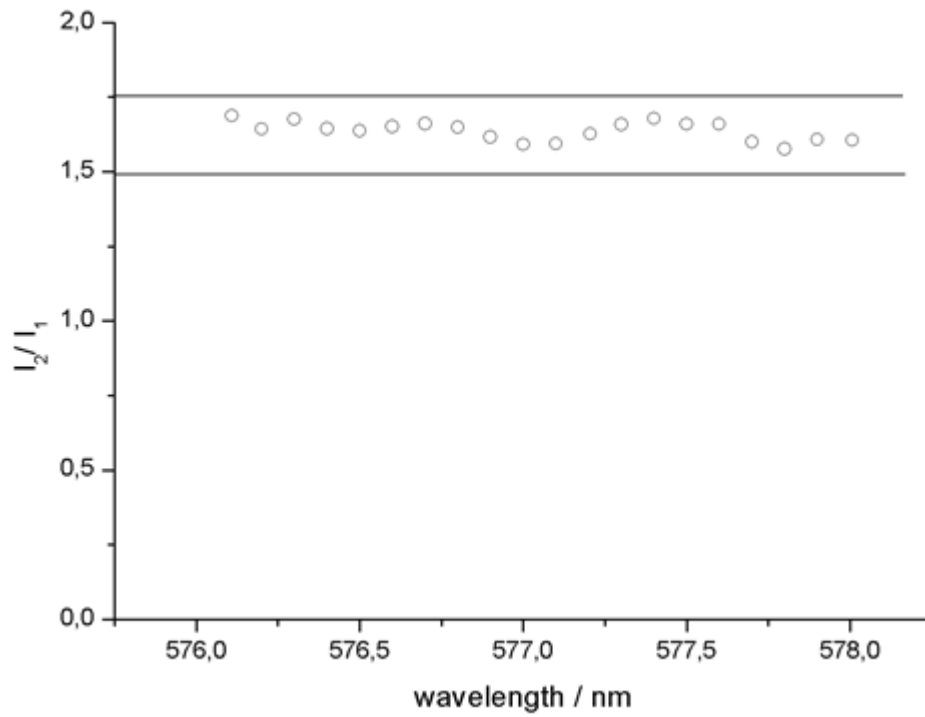

Figure 5-15 Ratio of intensities of 577 nm line with and without the duplicating mirror

The experimental correction factor, $K_{\lambda,corr} = \ln \frac{\left[\frac{R^C - 1}{R\lambda - 1} \right]}{1 - \frac{R\lambda - 1}{R^C - 1}}$, introduced in Chapter 3.2, was also calculated and shown in Figure 5-16.

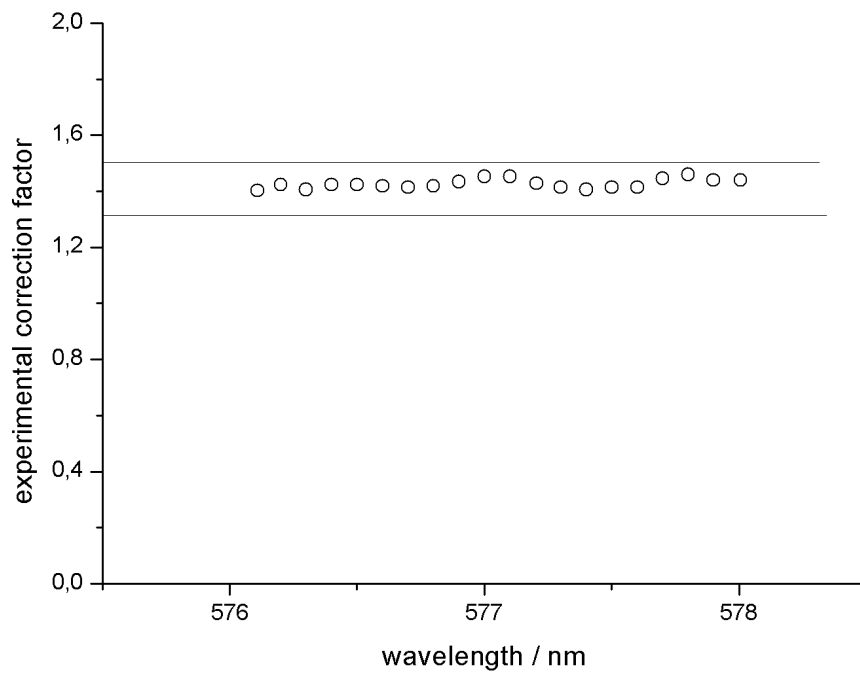

Figure 5-16 Experimental correction factor for 577 nm line

Figures above indicate that observed spectral line is optically thin and thus their observed spectral radiances can be transformed into radial distribution of the emission of the plasma using Abel inversion.

5.3. RESULTS

The mercury lines 577 nm and 1014 nm from high pressure In - Hg discharge were observed. Two types of measurements were performed – one in the time averaged mode and another one in the time resolved mode. That made it possible to observe the spectral lines for different phases of driving current.

The observed spectral lines were on the uneven background (Fig. 5-17). Zollweg et al. (Zollweg & Liebermann, Continuum radiation from the mercury arc, 1977) and Mosburg (Mosburg & Wilke, 1977) have observed and described continuum radiation from the mercury arc. Using FORTRAN program Minuit (Roos, 1975), the background was determined and then subtracted. The background was approximated with a quadratic function. The spectrum when the background was subtracted is also shown in Figure 5-17.

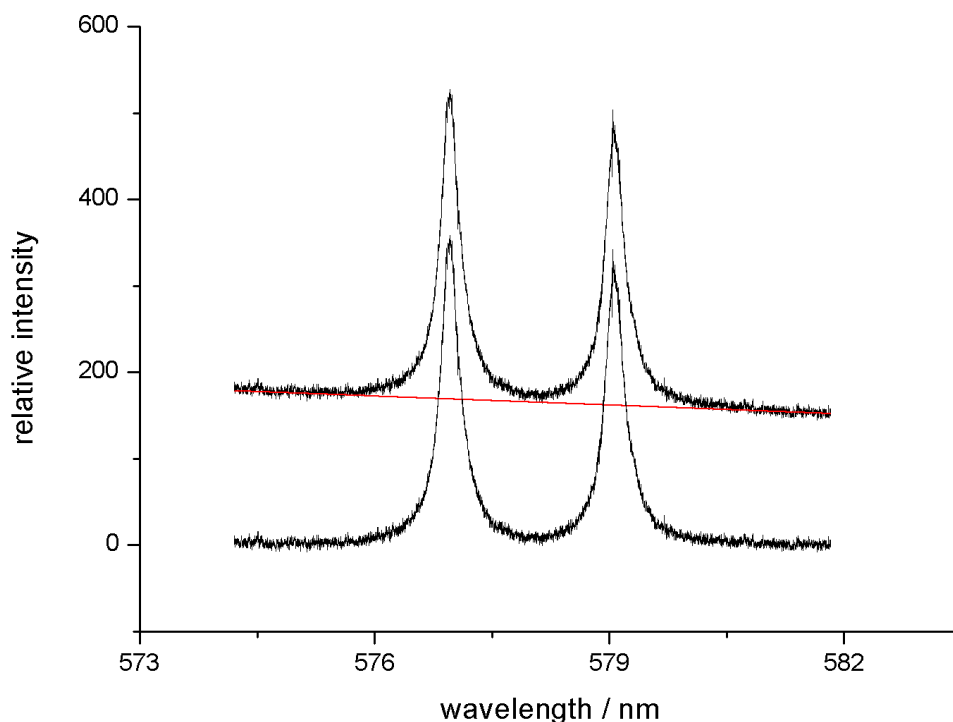

Figure 5-17 Example of the 577 nm and 579 nm lines on the uneven background. Red line shows the background. The lower spectrum shows the spectrum after the background correction.

5.3.1. TIME-AVERAGED OR AC MEASUREMENTS

The observed lines (with background correction) were plotted and the Voigt profile was fitted to the lines (Figure). Thus the relative intensities and width of the spectral lines were calculated.

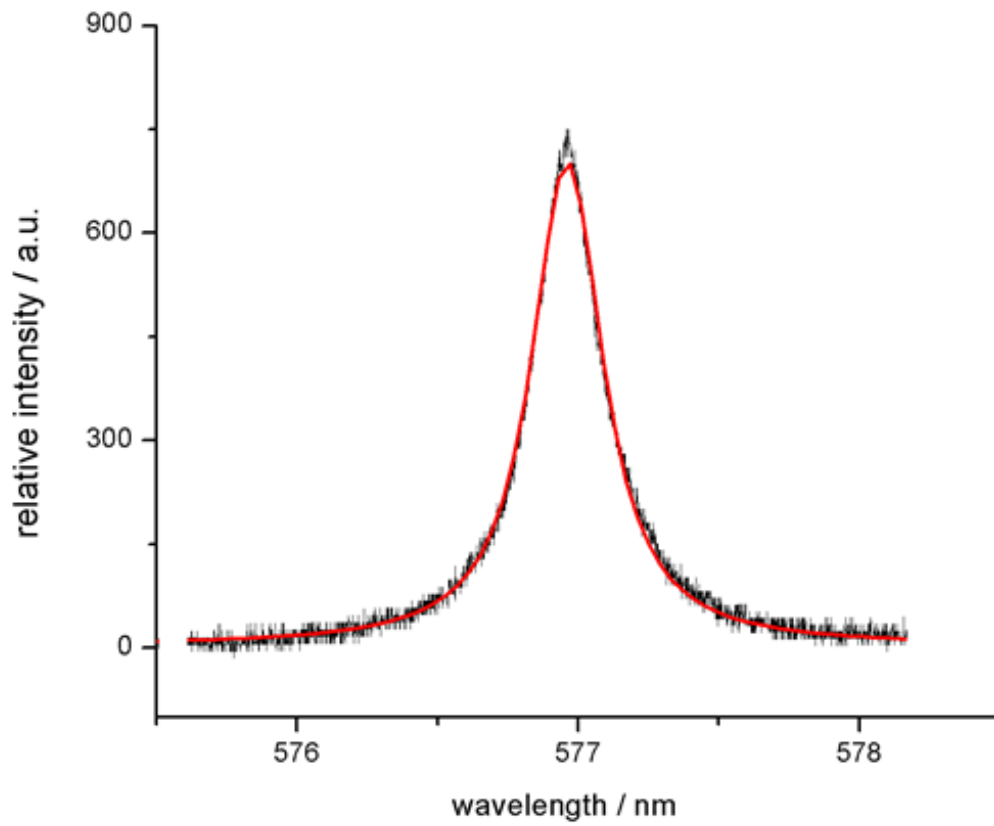

Figure 5-18 Line 577 nm and corresponding Voigt profile (red). For this line, the instrumental (Gauss) width is 0.08 nm and corresponding Lorentz width equals (0.2838 ± 0.0007) nm

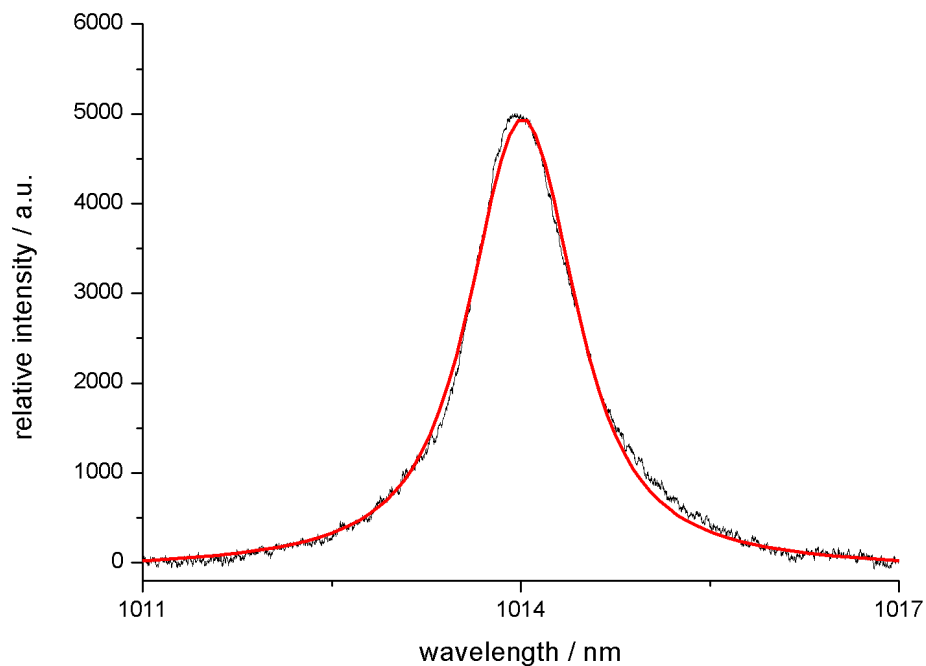

Figure 5-19 Line 1014 nm and corresponding Voigt profile. The instrumental (Gauss) width is 0.4nm and corresponding Lorentz profile is (0.833 ± 0.002) nm

The shape of the both spectral lines is convolution of instrumental and collisional broadening represented by Gauss and Lorentz function and is represented with the Voigt function. The Gauss profile of spectral line is determined from the instrumental function of the monochromator and Figures 5-7 and 5-8. The width of corresponding Lorentz profile is obtained by a fitting procedure from Voigt profile.

The shape of the mercury spectral lines were recorded for different positions of the lens L_2 in figure 5-1, thus the intensity distribution from different lateral columns of the discharge was measured. The intensity distribution was recorded for the radiation from the center of the discharge and for the radiation in steps of 0,375 mm to the left and right from the center. From each spectral line the Lorentz width of the line is determined and the results are presented in the Figures 5-20 and 5-21.

MEASUREMENT OF GROUND STATE Hg DENSITY

For the determination of the density of the neutral mercury atoms in discharge, resonance broadening of the 577 nm spectral line ($6^3D_2 - 6^1P_1$) and 1014 nm spectral line ($7^1S_0 - 6^1P_1$) was used. The analysis of the pressure broadening and the procedure for determining the width of the spectral lines is given in Chapter 3. Figures 5-20 and 5-21 show the measured widths of spectral lines in dependence of the cord offset (x).

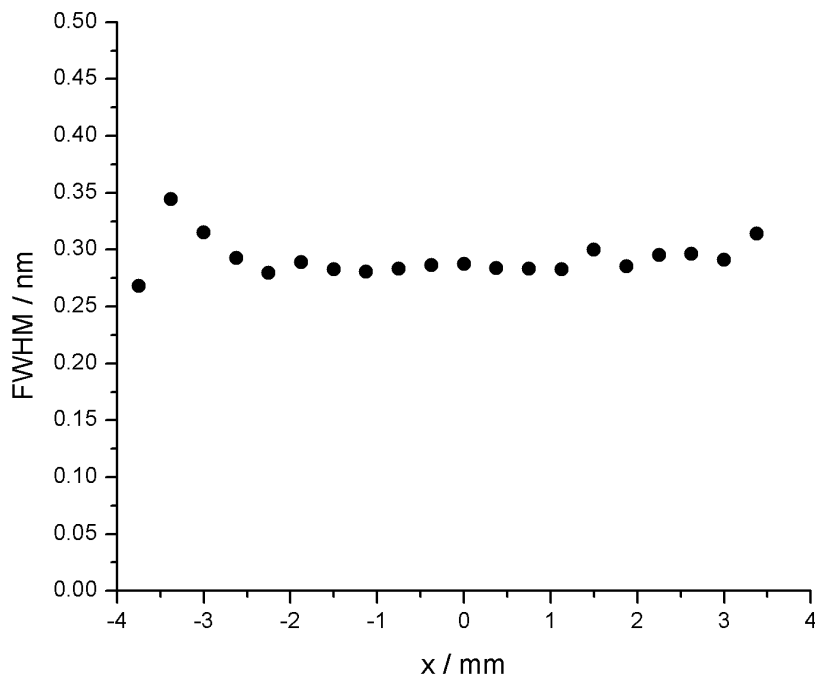

Figure 5-20 FWHM of 577 nm line in dependence of chord offset

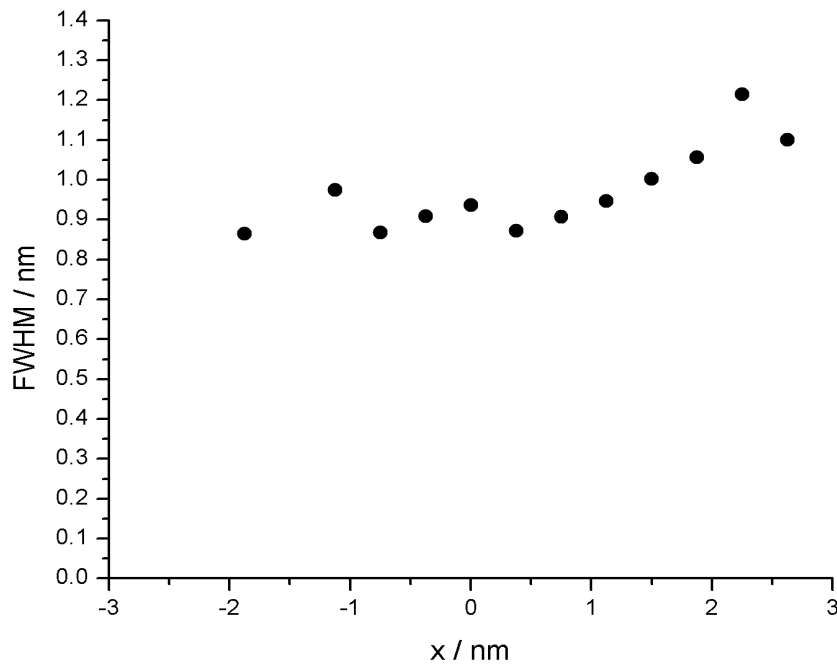

Figure 5-21 FWHM of 1014 nm line in dependence of chord offset

The density of the neutral mercury atoms was calculated according to the equation 5-59. In the center of the discharge it equals: $1,93 \cdot 10^{18} \text{ cm}^{-3}$ (577 nm line) to $2,09 \cdot 10^{18} \text{ cm}^{-3}$ (1014 nm line), respectively. The relative uncertainty in density of neutral mercury atoms can be calculated as:

$$\left| \frac{\Delta N}{N} \right| = \sqrt{\left(\frac{\Delta \lambda_{1/2}}{\lambda_{1/2}} \right)^2 + \left(\frac{\Delta f}{f} \right)^2},$$

where $\Delta \lambda_{1/2}$ is the uncertainty in determining the width of the spectral line and Δf is the uncertainty in the determining the oscillator strength which depends on transition probability. These two uncertainties are estimated to give the relative uncertainty in density of neutral mercury atoms to be 10% and the result can be written as:

$$N = (2 \pm 0,2) \cdot 10^{18} \text{ cm}^{-3}$$

TEMPERATURE OF DISCHARGE

Electron temperature of the discharge is determined from the absolute intensity of the optically thin 577 nm spectral line. Figure 5-22 shows measured relative intensities (points) of 577 nm spectral line as a function of chord offset. Relative intensity was measured for center of the discharge and for series of measurement in chord offset. The distribution of points is very well fitted by Gauss profile with $\Delta x_G = (2.45 \pm 0.02)$ mm and $x_C = (3.739 \pm 0.007)$ mm. This (x_C) represents the axis of symmetry of our arc. The radius of the discharge is at the point where $I(r_0) = 1/10 I_{max}$ and r_0 equals 2.72 mm.

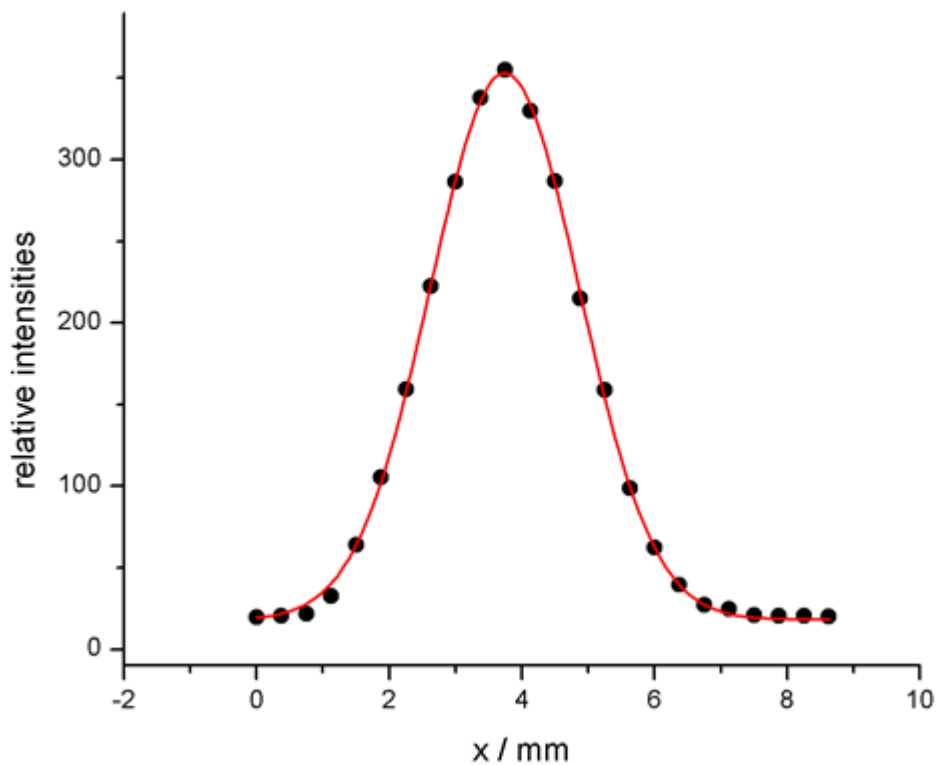

Figure 5-22 Measured relative intensities (points) of 577 nm spectral line as a function of chord offset. The distribution of points is very well fitted by Gauss profile with $\Delta x_G = (2.45 \pm 0.02)$ mm. Center of the discharge is in point $x_C = (3.739 \pm 0.007)$ mm

From the Gauss curve in Figure 5-22 a sequence of 10 equidistant readings for relative intensities was taken. The radiances along a diameter of the arc chord were calculated using the radiance of the high pressure discharge calculated in chapter 5.2.3. The result for radiances as a function of chord offset is shown in Figure 5-23.

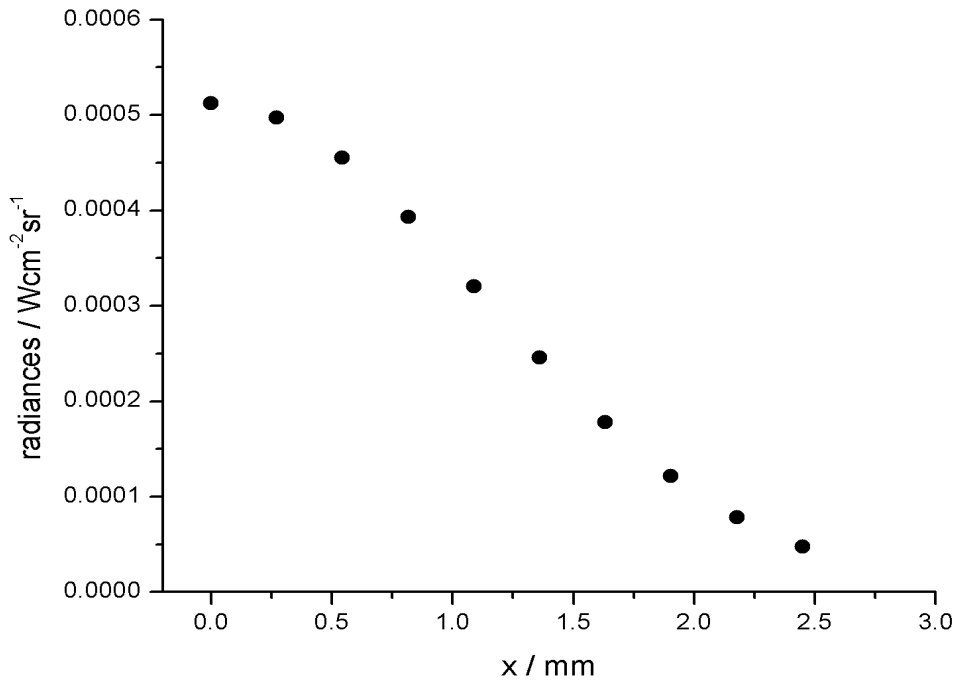

Figure 5-23 Radiance as a function of chord offset

Using the radiance from figure 5-23 and the coefficients for Abel inversion, the absolute emission coefficients were calculated and represented in figure 5-24.

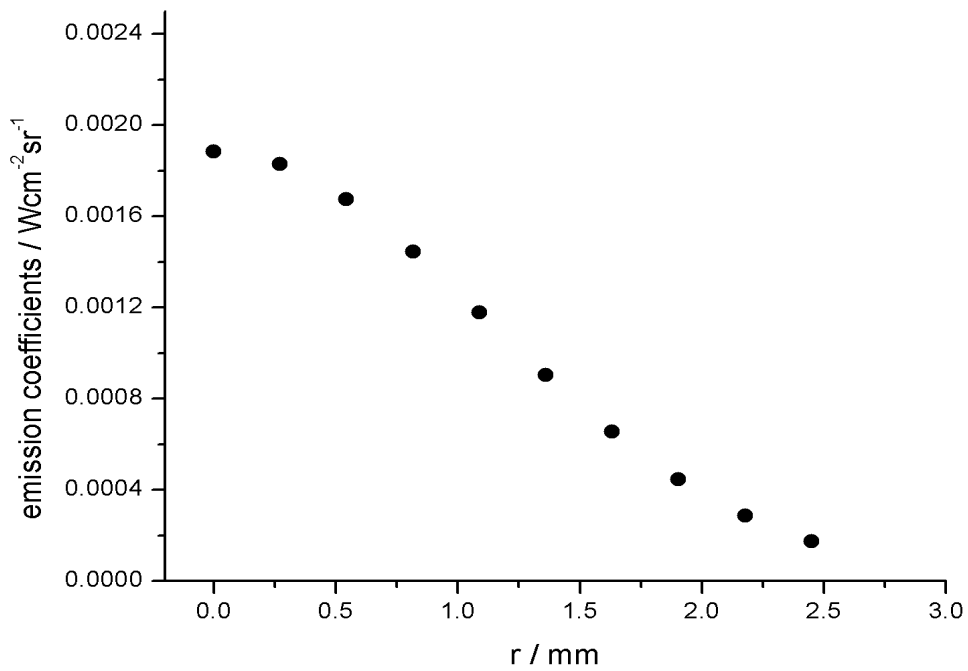

Figure 5-24 Emission coefficients as a function of distance r from the center of the discharge

Using equation 3-68 the electron temperature as a function of the chord offset was calculated and represented in figure 5-25.

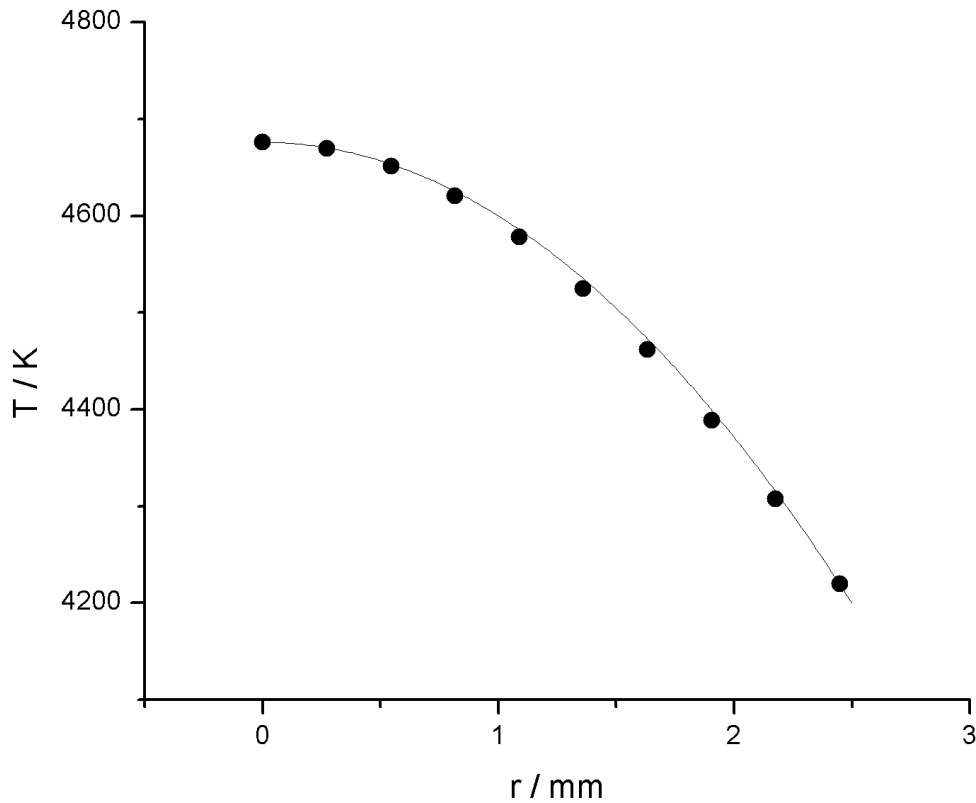

Figure 5-25 Dependence of the temperature of the discharge on the distance r from the center of the discharge

The temperature profile in the graph above can be best represented with the following function:

$$T(r) = T_C - (T_C - T_0) \frac{r^2}{r_0^2}, \quad (5-5)$$

where T_0 is the temperature at r_0 and equals 4220 K, and T_C is the arc core temperature and in our case it equals 4676 K.

Temperature was determined from absolute intensity of the optically thin 577 nm spectral line. This implies that more sources of uncertainty need to be evaluated. First is the uncertainty in measurement of intensity ΔI_{meas} , than uncertainty in absorption correction factor $\Delta K_{\lambda,corr}$, uncertainty in density of neutral mercury atoms, uncertainty of coefficients

in Abel inversion ΔA and the uncertainty in determining the absolute intensity by comparison of high and low pressure mercury sources. Thus the relative uncertainty in temperature can be written as:

$$\left| \frac{\Delta T}{T} \right| = \sqrt{\left(\frac{\Delta I_{meas}}{I_{meas}} \right)^2 + \left(\frac{\Delta K}{K} \right)^2 + \left(\frac{\Delta A}{A} \right)^2 + \left(\frac{\Delta I_{abs}}{I_{abs}} \right)^2 + \left(\frac{\Delta N}{N} \right)^2}.$$

Based on the all influences to the uncertainty, the relative uncertainty of temperature measurements was estimated to 15 %, and the temperature in the center of the discharge can be written as $T = (4675 \pm 701)K$

Knowing electron temperature and the density of the neutral mercury atoms in the ground state, the pressure of the mercury vapors can be determined, using the assumption that mercury vapors in the discharge can be approximated with an ideal gas:

$$p_{Hg} = N_{Hg} k_B T_e. \quad (5-6)$$

From the equation above, and using measured values for N_{Hg} and T_e the pressure of the mercury vapors equals $(1,3 \pm 0,2) \cdot 10^5 \text{ Pa} = (1,3 \pm 0,2) \text{ atm}$.

5.3.1. TIME-RESOLVED MEASUREMENTS USING BOXCAR AVERAGER

Time-averaged measurements described in previous chapter gave the line profiles where the each point in a profile represents the average value over more periods of AC current. Using Boxcar Averager plasma radiation was measured with time resolution. Both lines 577, nm and 1014 nm were observed and all recorded data were analyzed on a same way as in time averaged mode.

In the first set of measurements the light from the center of the discharge was observed and only the phase of the current was changed in order to observe how does the intensity and width of the spectral lines change with change of the phase. The results obtained for line 577 nm are shown in figure 5-26.

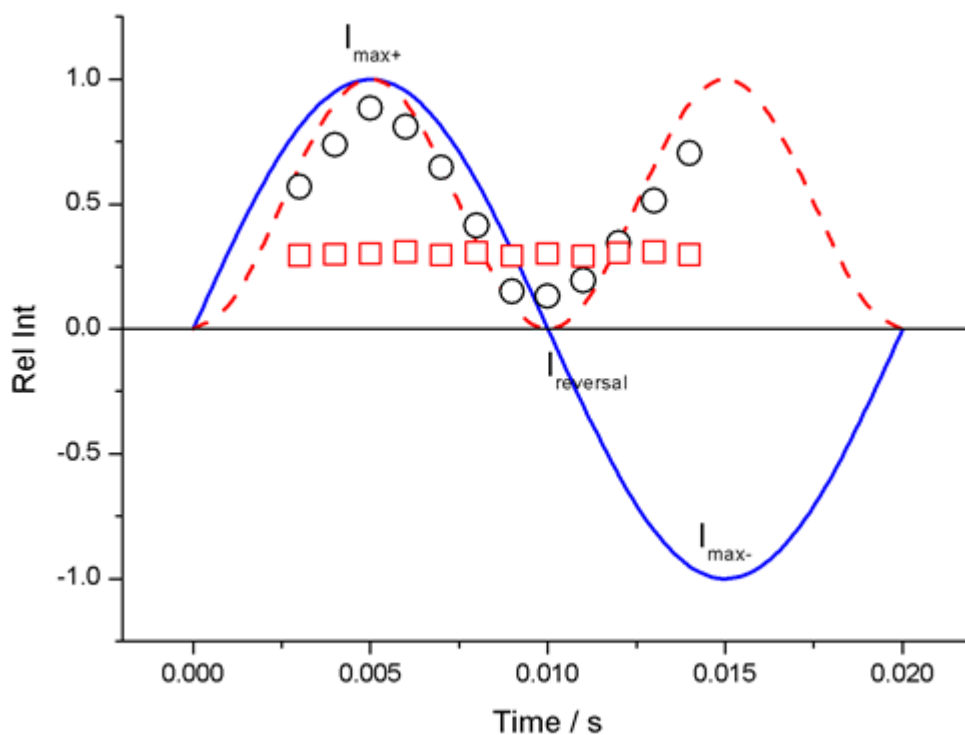

Figure 5-26 Normalized line intensities and line widths are shown for different phases of the current. The blue sinusoidal line shows the current. Red dashed line represents the absolute value of the sine function. Circles show the relative intensities and square the FWHM of the spectral line.

First, the general behavior of line widths and intensities was observed for different phases of current. Second, intensities and line widths were measured for different lateral plasma columns (for different chord offsets). Measurements were repeated for minimum and maximum of current as well as for three current phases in between I_{min} and I_{max} .

As it can be seen on the figures 5-27 and 5-58 for different phases of current the relative intensities and FWHMs change. More precisely, for I_{max} the relative intensity is also maximal and it is smaller for all other phases of current. The same is with the temperature, which changes with the intensity. From figure 5-58 it is observed that FWHMs also change, and thus the density of the neutral mercury atoms also change.

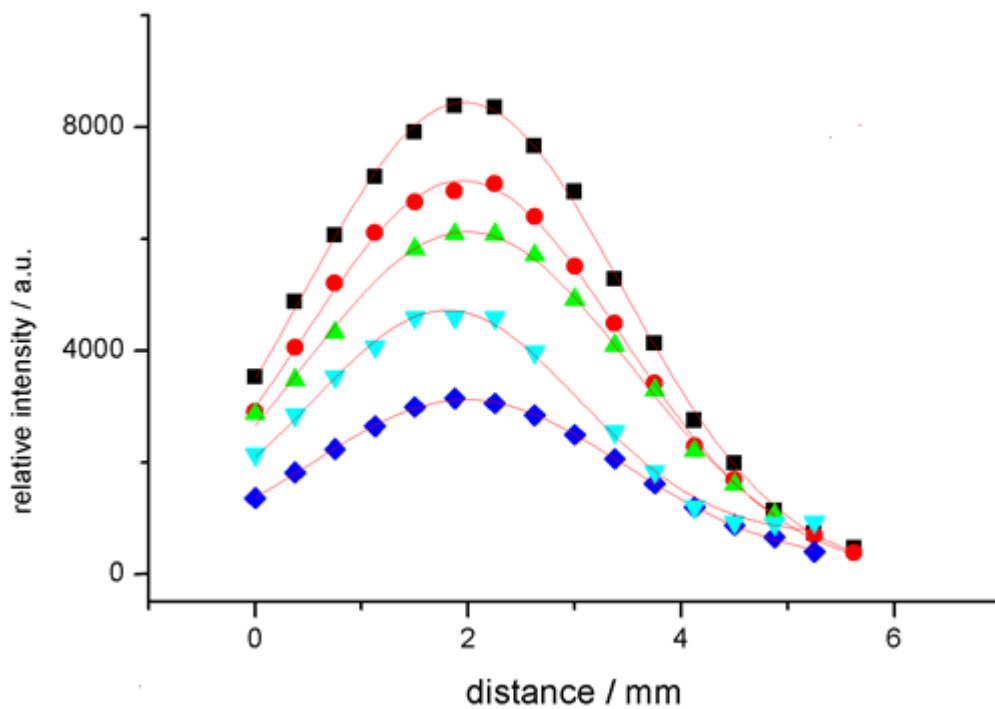

Figure 5-27 Relative intensities of the 1014 nm spectral line as a function of chord offset. Intensities were determined for different phases of current. Measurements were repeated for minimum and maximum of current as well as for three current phases in between I_{min} and I_{max} . Center of the discharge is at $x = 2$ mm.

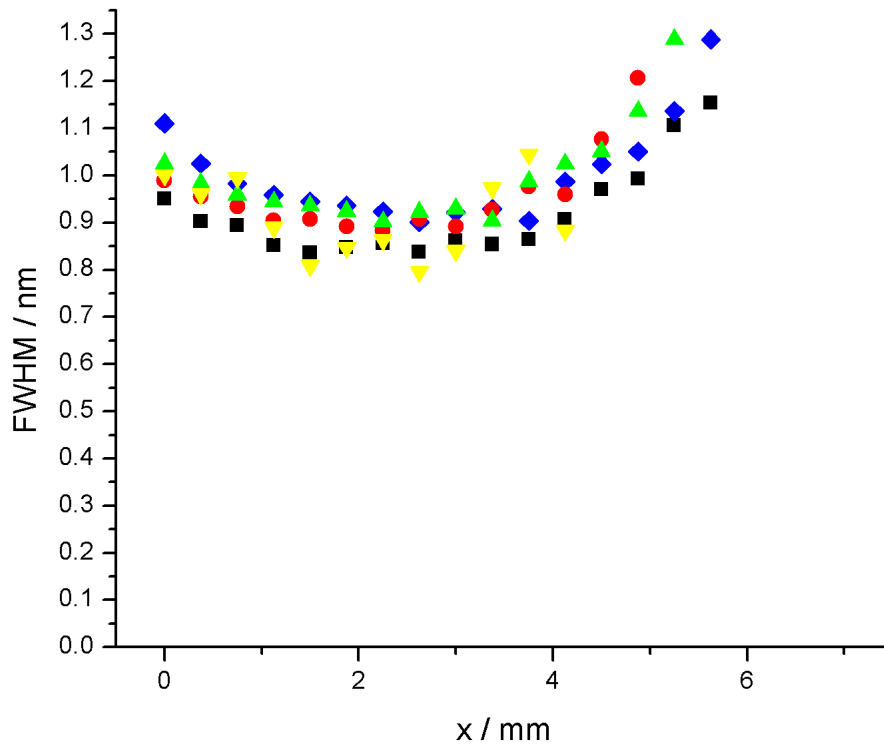

Figure 5-28 FWHM of the 1014 nm spectral line as a function of chord offset. FWHMs were determined for different phases of current. Measurements were repeated for minimum and maximum of current as well as for three current phases in between I_{min} and I_{max} . Center of the discharge is at $x = 2$ mm.

6. DISCUSSION

Plasma parameters of high pressure metal halide discharge containing mercury and indium were determined using the time averaged measurements – electronic temperature, density of neutral mercury atoms and the pressure of the mercury vapors. Electronic temperature is $T = (4676 \pm 701)$ K in the center of the discharge and $T = (3490 \pm 524)$ K on the edge of the discharge. Density of neutral mercury atoms in the ground state was determined to be: $N = (2 \pm 0.2) \cdot 10^{18} \text{ cm}^{-3}$ and the pressure of the mercury vapors is $p = (1,3 \pm 0,2) \cdot 10^5$ Pa.

Using the method of absolute intensities of optically thin 577 nm mercury line in Hg-In discharge, the electronic temperature in the center of the discharge is determined. Relative lateral intensities were measured. Using Abel transformation these intensities were transformed into distribution of the radially dependent emission coefficients ($\epsilon(r)$) of plasma. The relative uncertainty of the temperature is estimated to 15%. It is due the uncertainty of the intensity measurement $I(x)$, uncertainty of correction factor $K_{\lambda,corr}$, uncertainty of coefficients in Abel inversion and the uncertainty in determining the absolute intensity.

Temperature was determined using Abel transformation from absolute intensities. Absolute intensities are obtained by comparison with low pressure “Pen Ray lamp” which is known as radiation standard (Childs, 1962). The same type of lamp was also investigated by Reader (Reader, Sansonetti, & Bridges, 1996) and the irradiances of 14 mercury spectral lines were compared with the irradiance of a calibrated continuum source. The lamp used by NIST and supplied by Oriel Instruments were operated in DC mode, while the lamp used by Childs were operated in AC mode, as well as one used in the research described in this dissertation. As described in Childs (Childs, 1962), the irradiance varies with the radial orientation, because the lamp appeared to be elliptical in cross section. The variation of irradiance around direction of maximum irradiance is about 3%. We have adjusted the position of lamp so that it is in a position near maximum output.

Another factor that contributed to the uncertainty is the correction factor $K_{\lambda,corr}$ obtained from the use of duplicating mirror (Moon, Herrera, Omenetto, Smith, & Winefordner, 2009). The contribution to total uncertainty is estimated to be 6%.

Densities of the neutral atoms of mercury in the ground state were determined using the resonance broadening of optically thin mercury lines at 577 nm ($6^3D_2 - 6^1P_1$) and 1014 nm ($7^1S_0 - 6^1P_1$). The uncertainty in determining the density of neutral mercury atoms in the ground state is estimated to be 10% and is due to the uncertainty in determining the FWHM of Lorentz profile of measured lines and due to the uncertainty in oscillator strength, i.e. transition probability. In this work, the transition probabilities from Lawler were used (Lawler, 2004). Griem's discussion (Ali & Griem, 1965) implies that the uncertainty in theoretical calculations of the half width at half maximum is about 10%. We have used the improved formula for the resonance impact broadening, also used in Kelleher (Kelleher, 1980).

Densities of the neutral mercury atoms calculated from 577 nm line and 1014 nm line are in the agreement with one another and also in agreement with the results from Lawler.

Figures 6-1 and 6-2 show the comparison between experimental FWHMs of the mercury 577 nm and 1014 nm spectral lines and the FWHMs for the same lines from the research of Lawler (Lawler, 2004)⁷. Figures show the FWHM as a function of the chord offset.

⁷ Lawler used MH HID lamp containing Hg (3.5 mg) with power of 150W.

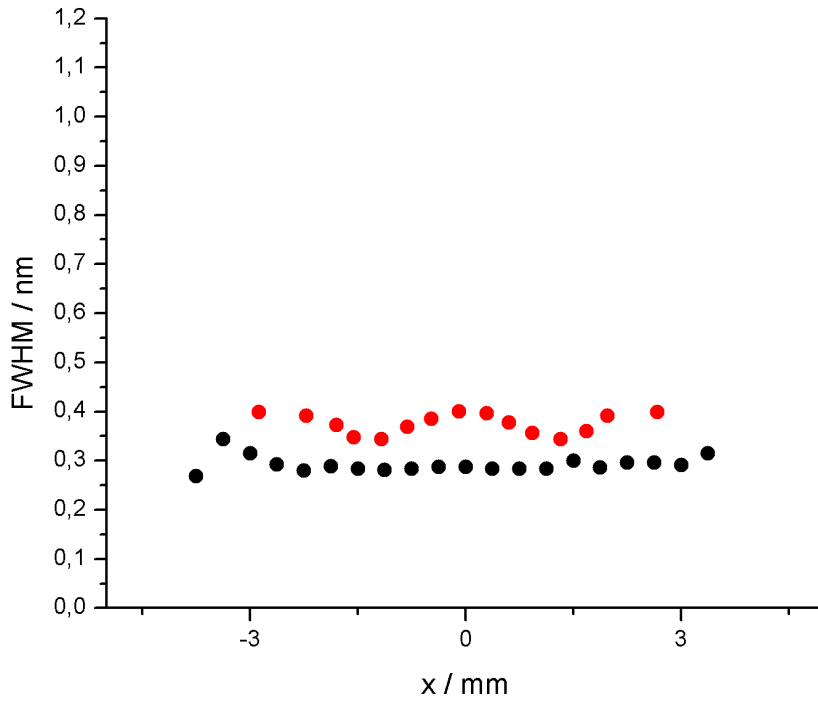

Figure 6-1 Comparison of FWHMs of 577 nm line as a function of chord offset. Red circles represent data from Lawler and black circles are our measurements.

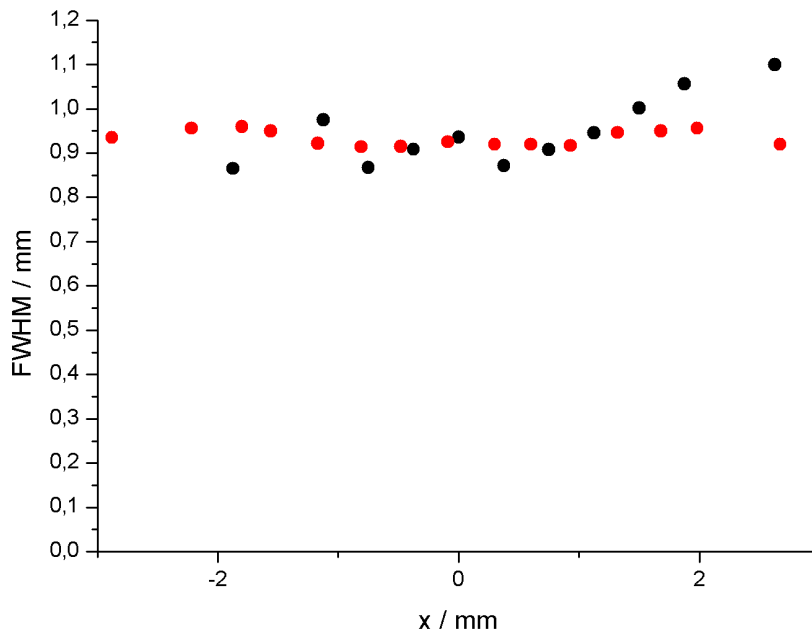

Figure 6-2 Comparison of FWHMs of 1014 nm line as a function of chord offset. Red circles represent data from Lawler and black dots are our measurements.

The FWHM of the line 577 nm is about three times smaller than the FWHM of the 1014 nm lines. Results from Lawler show that the width of the 577 nm line decreases with increasing chord offset, while our measurements show constant values near the center of the discharge and starts to increase for larger chord offsets.

Lawler showed that the width of the 1014 nm line increases slightly with increasing chord offsets, and then decreases for large chord offsets. FWHMs from our measurement for 1014 nm line show the similar behavior as the measurements from Lawler.

Calculated Hg density is about 10^{18} cm^{-3} , and according to Lawler (Lawler, 2004) the resonance broadening is applicable for Hg densities up to $2 \cdot 10^{20} \text{ cm}^{-3}$.

Radial distribution of the temperature was obtained from the radial dependent emission coefficients $\varepsilon(r)$ of plasma and is shown in Figure 6-3.

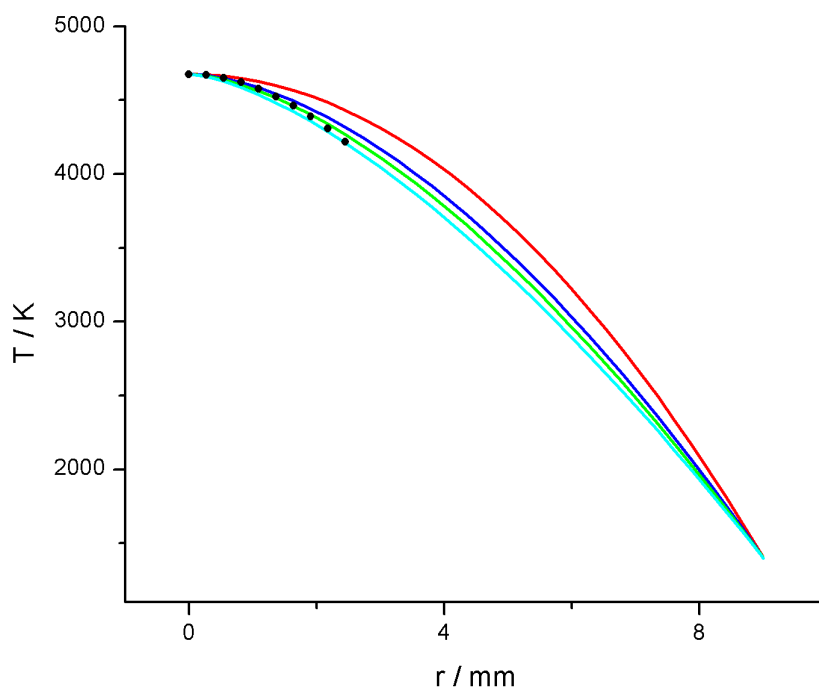

Figure 6-3 Experimental temperatures (points) compared with different temperature profiles. Red line corresponds to $\beta = 2$, the dark blue one to $\beta = 1.7$, the green one to $\beta = 1.6$ and the light blue one to $\beta = 1.5$

Temperature profile whose analytic form is given by:

$$T(r) = T_C - (T_C - T_w) \frac{r^\beta}{r_{in}^\beta},$$

where T_w is the wall temperature (assumed to be 1400 K, the temperature limit of fused silica). T_C is the arc core temperature and in our case it equals 4676 K and β is a free coefficient.

As it can be observed from Figure 6-3, $\beta = 1.5$ and 1.6 best fit the experimental data, which indicates that there is an arc constriction. Results from Zollweg (Zollweg, Lowke, & Liebermann, 1975) show that arc constriction is due to the presence of the halogen atoms (iodine in this case) in the discharge. Their temperature profiles for pure Hg and for Hg with the addition of iodine were plotted as a function of chord offset and the results are represented in figure 6-4. Figure shows that addition of iodine leads to arc constriction.

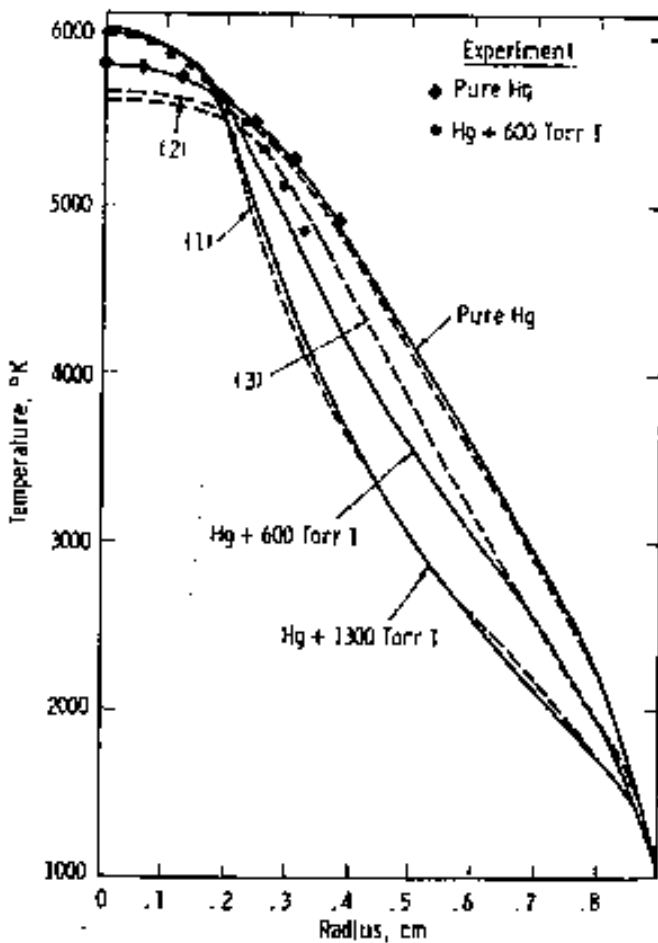

Figure 6-4 Theoretical temperature profile compared with experimental temperatures from Zollweg

In the calculations of radial temperature distribution (see Equation 3-58), in use of Abel inversion, parameter r_0 is the radius of the discharge at the point where $I(r_0) = 1/10 I_{max}$ and r_0 equals 2.72 mm. If we take the r_0 as the radius of the discharge at the point where $I(r_0) = 1/20 I_{max}$ and then the r_0 would equal 4.7 mm. That would also influence the radial temperature distribution as well as the core temperature. The core temperature with radius $r_0 = 4.7$ mm equals (4562 ± 683) K. Figure 6-5 shows temperature distribution for two different radii r_0 .

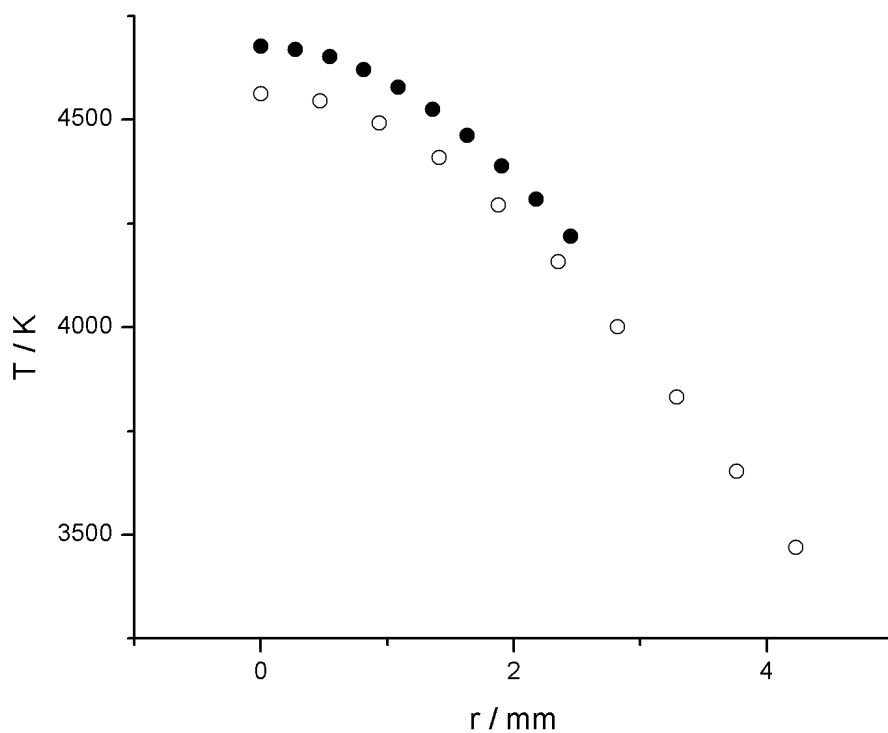

Figure 6-5 Temperature distribution for $r_0 = 4.7$ mm (empty circles) and $r_0 = 2.72$ mm (full circles)

Dakin *at al.* (Dakin, 1989) have investigated the high-pressure Hg discharge with metal halide additives and the discharge temperature based on 577 nm line and its axial and radial variations. The results are presented in Figure 6-6. He observed that the temperature is higher near the electrodes and lower in the center of the discharge. We have observed the temperature in the center of the discharge, just between two electrodes. In work of Dakin the temperature is observed to be about 5000 K in the center of the discharge. This result is, within experimental error, close to our measurements.

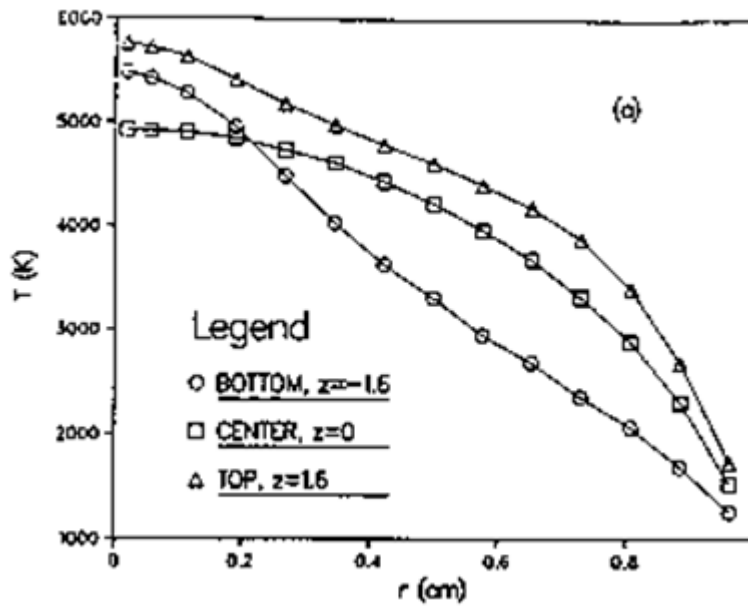

Figure 6-6 Radial variations of the discharge temperature

Stromberg and Schaffer (Stormberg & Schaeffer, 1983) described the time-resolved behavior of a mercury discharge. They were measuring the axis temperature as a function of time and have observed that the temperature varies between 5000 K (for the current reversal) and about 6000 K (for the maximum of the current) and that this dependence is sinusoidal. Our results for time resolved measurements show (Fig. 5-27) the similar dependence of the relative intensities with the change of current phase. Stromberg and Schaffer also showed that the temperature profile is: $T(r) = T_C - (T_C - T_0) \frac{r^\beta}{r_0^\beta}$ and that the approximation is good for β between 2 and 3.5.

Karabourniotis (Karabourniotis, 2003) has determined the electronic temperatures in two AC operated high-pressure pure-Hg discharges. The temperature in the center of the discharge is measured and it equals to 8314 ± 145 K for 1.9 bar discharge and 6720 ± 105 K for 6.2 bar discharge. Our data show that the temperature of the discharge containing mercury and indium is lower than the temperature in the pure Hg-discharge. This can be explained with the presence of indium which has much smaller ionization potential (46670 cm^{-1}) than mercury (84184 cm^{-1}).

BIBLIOGRAPHY

- Abjean, & Johannin-Gilles. (1976). Oscillator strengths measurement by atomic beam absorption—III. Oscillator strength of the Hg(I) 1P1–1S0 transition ($\lambda = 1850 \text{ \AA}$). *J. Quant. Spectrosc. Radiat. Transfer*, 369.
- Ali, & Griem. (1965). Theory of resonance broadening of spectral lines by atom-atom impacts. *Physical Review*, 1044-1049.
- Ambrose, B., Shaffer, P., Steinberg, R., & McDermott, L. (1999). An investigation of student understanding of single-slit diffraction and double-slit interference. *Am. J. Phys.*
- Aragon, C., & Aguilera, J. (2008). Characterisation of laser induced plasmas by optical emission spectroscopy: A review of experiments and methods. *Spectrochimica Acta Part B*, 893-916.
- Asikainen, M., & Hirvonen, P. (2009). A study of pre- and inservice physics teachers' understanding of photoelectric phenomenon as part of the development of a research-based quantum physics course. *Am.J.Phys.*, 658-666.
- Bardar. (2006). *Development and analysis of spectroscopic learning tools and the light and spectroscopy inventory for introductory college astronomy*. Boston: Boston University.
- Bockasten. (1961). Transformation of Observed Radiances into Radial Distribution of the Emission of a Plasma. *J. Opt. Soc. Am.*, 943.
- Bousquet, & Bras. (1980). *J. Phys.*, 19.
- Childs. (1962). Low-Pressure Mercury Arc for Ultraviolet Calibration. 711-716.
- Comins. (2001). *Heavenly Errors*. New York: Columbia University Press .
- Dakin. (1989). Anatomy of vertical metal halide discharge. *J. Appl. Phys.*, pp. 4047-4087.
- Demtroeder, W. (1998). *Laser Spectroscopy*. Berlin: Springer-Verlag.
- Gebhard, & Behmenburg. (1975). Resonance broadening and oscillator strength of the mercury absorption line 1850 Å. *Naturforsch, Teil A*, 445.
- Heron, P., & McDermott, L. (1998). Bridging the gap between teaching and learning in geometrical optics: The role of research. *Opt. & Phot. News*, 30.
- Karabourniotis, D. (2003). Excitation temperatures in the ionizing plasma of high-pressure mercury discharge. *Applied Physics Letters*, pp. 5395-5397.
- Kelleher, D. E. (1980). Stark broadening of visible neutral helium lines in a plasma. *J. Quant.Spectrosc.Radiat.Transfer*, pp. 191-220.
- Lawler. (2004). Resonance Broadening of Hg lines as a density diagnostics in high intensity discharge lamps. *Plasma Sources Science and Technology*, 321-328.

- Lecler. (1968). *J. Phys*, 611.
- Lee. (2002). *Student understanding of spectra*. Manhattan, Kansas: Kansas State University.
- Lochte-Holtgreven. (1968). *Plasma Diagnostics*. Amsterdam: North-Holland publishing company.
- Lurio, A. (1965). Lifetime of the 6s6p 1P1 state of mercury. *Phys. Rev.*, A1505–A1508 .
- McDermott. (1991). What we teach and what is learned: Closing the gap. *Am. J. Phys.*, 301.
- McDermott, L. (2001). Oersted Medal Lecture 2001: "Physics Education Research – The Key to Student Learning". *Am. J. Phys.*
- McDermott, L., Shaffer, P., & Physics Education Group, U. o. (2002). *Tutorials in Introductory Physics, First Edition*. Upper Saddle River: Prentice Ha.
- McDermott, Shaffer, & Somers. (1994). Research as a guide for teaching introductory mechanics: An illustration in the context of the Atwood's machine. *Am. J. Phys.*, 46-55.
- Menningen, & Lawler. (2000). Radiation Trapping of the Hg 185 nm Resonance Line. *J.Appl.Phys.*, 3190.
- Moon, Herrera, Omenetto, Smith, & Winefordner. (2009). On the usefulness of duplicating mirror to evaluate self-absorption effects in laser induced breakdown spectroscopy. *Spectrochimica Acta Part B*, 702-713.
- Mosburg, E., & Wilke, M. (1977). Excimer densities and destruction mechanisms in a high pressure pure mercury positive column. *The Journal of Chemical Physics*.
- Osram. (n.d.). *Metal halide lamps - Instruction for the use and application*. Retrieved from www.osram.com
- Planinic, M. (2006). Assessment of difficulties of some conceptual areas from electricity and magnetism using the Conceptual Survey of Electricity and Magnetism. *Am. J. Phys.*, 1143-1148 .
- Planinic, M., Boone, W. J., Krsnik, R., & Beilfuss, M. (2006). Exploring Alternative Conceptions From Newtonian Dynamics and Simple DC Circuits: Links Between Item Difficulty and Item Confidence. *Journal of Research in Science Teaching*, 150 - 171 .
- Planinic, M., Ivanjek, L., & Susac, A. (2010). The Rasch model based analysis of the Force Concept Inventory. *Physical Review Special Topics - Physics Education Research*.
- Reader, J., Sansonetti, C., & Bridges, J. (1996). Irradiances of spectral lines in mercury pencil lamps. *Applied Optics*, pp. 78-83.
- Roos, J. a. (1975). MINUIT - a system function minimization and analysis of the parameter errors and correlations. *Computer physics communications*, pp. 343 - 367.
- Sobel'man, I. (1972). *Introduction to the Theory of Atomic Spectra*. Oxford: Pergamon Press.

- Stormberg, H., & Schaeffer, R. (1983). Time-dependent behaviour of high-pressure mercury discharges. *J.Appl.Phys.*, pp. 4338-4347.
- Stromberg. (1979). Line Broadening and radiative transport in high-pressure mercury discharges with NaI and TII as aditives. *J.Appl. Phys.*, 1963-1969.
- Thorne, a. (1975). *Spectrophysics*. London: Chapman and Hall.
- Vokos, S., Ambrose, B., Shaffer, P., & McDermott, L. (2000). Student understanding of the wave nature of matter: Diffraction and interference of particles. *Am.J.Phys.*
- Wosilait, K., Heron, P., Shaffer, P., & McDermot, L. (1999). Addressing student difficulties in applying a wave model to the interference and diffraction of light. *Am. J. Phys. Suppl.*
- Wosilait, K., Heron, P., Shaffer, P., & McDermott, L. (1998). Development and assessment of a research-based tutorial on light and shadow. *Am.J.Phys.*, 906.
- Zollweg, R., & Liebermann, R. (1977). Continuum radiation from the mercury arc. *J. Quant. Spectrosc. Tranfer*, pp. 133-141.
- Zollweg, R., Lowke, J., & Liebermann, R. (1975). Arc constriction in lamps containing mercury and iodine. *Journal of Applied Physics*, pp. 3828-3838.

APPENDIX A: TUTORIAL, INTERACTIVE TUTORIAL LECTURE AND TUTORIAL HOMEWORK

A – 1 SPECTRA TUTORIAL – ORIGINAL VERSION

A – 2 SPECTRA – INTERACTIVE TUTORIAL LECTURE

A – 3 SPECTRA HOMEWORK – VERSION ONE

A – 4 SPECTRA HOMEWORK – VERSION TWO

A – 5 SPECTRA TUTORIAL – OPTICAL SYSTEMS

A – 6 SPECTRA TUTORIAL – CROATIAN VERSION: OPTICAL SYSTEMS

A – 7 SPECTRA TUTORIAL – CROATIAN VERSION: ENERGY LEVELS

A – 8 TUTORIAL HANDOUT

A – 1 SPECTRA TUTORIAL – ORIGINAL VERSION

SPECTROSCOPY

ST
1

I. Discrete Spectra

- A. A hydrogen lamp is placed in front of a mask with a 1 mm slit. A prism is between the mask and a screen as shown. The pattern shown is observed on the screen.

Consider the following discussion.

Student 1: "The line at far right has the largest wavelength, which means the largest frequency. So that line corresponds to the highest energy value and represents the highest energy level of hydrogen."

Student 2: "I disagree. The energy of one energy level equals hf and frequency is inversely proportional to wavelength. That means that the line at the far right corresponds to the ground energy level."

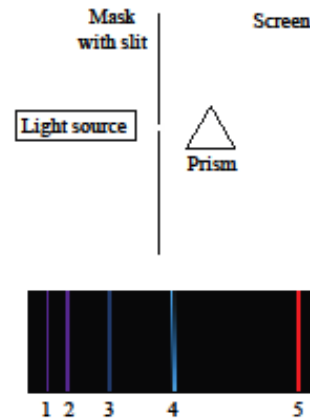

Which student, if either, do you agree? Explain your reasoning.

- B. The table below shows the measured wavelengths of the lines in the spectrum above. Use the information provided to calculate the energy of the photons that form these lines. Fill in the third column of the table with the photon energies in electron volts. (Planck constant, $h = 6.62 \times 10^{-34}$ J s, speed of light, $c = 3.0 \times 10^8$ m/s, $1 \text{ eV} = 1.6 \times 10^{-19}$ J)

Line Number	Wavelength	Photon Energy (from Part B)	Formula relating photon energies to energy levels (answer after completing Part C)
2	410.2 nm		
3	434.1 nm		
4	486.1 nm		
5	656.3 nm		

- C. The diagram at right shows some of the energy levels for an electron in a hydrogen atom. The energies are calculated from the Schrödinger equation.

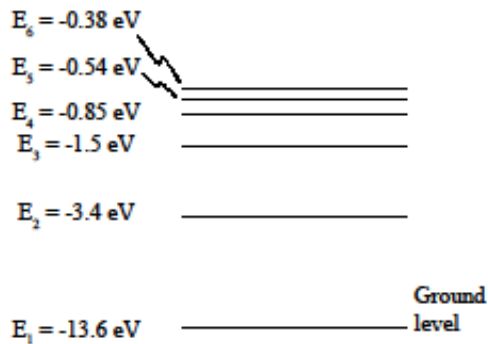

How are the energies in the diagram algebraically related to the photon energies in the third column in the table in part B?

On the basis of your answer above, complete the fourth column in the table.

(Spacing not to scale)

- D. Based on the formula you found in part 1, describe what happens to the hydrogen atom when a photon is emitted. Discuss how the process is consistent with energy conservation. As part of your answer, discuss explicitly the negative signs in the energies above.

- E. Refer again to the discussion among students in part A. Do you agree with your original answer? If you disagree with any of the students, identify what is incorrect with their statements.

★ Discuss your answers with a tutorial instructor.

The lines shown in part A are in the visible part of the spectrum. These lines are part of what is called the Balmer series, named after Johann Balmer, a Swiss teacher who found a formula for calculating these lines. It was later recognized that the Balmer series corresponds to transitions to the second excited energy level in hydrogen ($n = 2$) from levels with n equal to three or greater. Transitions between other energy levels are found in other parts of the spectrum for hydrogen.

II. Pattern of lines in discrete spectra

A. The energy-level diagram in section I, part C shows the lowest six energy levels for hydrogen.

1. Calculate the ratio of E_1 to E_2 , E_1 to E_3 and E_1 to E_4 .
2. In general, how is the value of E_n algebraically related to E_1 ?
3. For a bound electron, is there any limit to the highest energy of the electron – proton system? Explain your reasoning.

Consider a line in the spectrum for hydrogen corresponding to a wavelength of 364.6 nm and photon energy 3.40 eV.

4. To which transition does this line correspond? Explain.
5. Where on the figure in part I.A would this line appear? Explain.

★ Discuss your answers with a tutorial instructor.

B. The picture at right shows the line spectrum resulting from a particular sample of gas. (Wavelength increases to the right.)

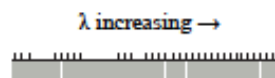

1. What is the minimum number of energy levels in each atom of a gas that could produce this spectrum? Explain.
2. Sketch the energy level diagram with the minimum number of energy levels that could produce these spectral lines. (The spacing between the levels should be consistent with the relationship you found in part II.A.)
3. Which transition corresponds to the line at the far right? (Imagine that all lines are formed from just these energy levels.) Explain.

C. The diagram at right shows a part of the spectrum resulting from hydrogen gas.

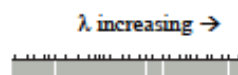

1. Based on the ideas developed in this tutorial would you expect the spectral lines to extend to infinity on the right part of spectrum? Explain.
2. Based on the ideas developed in this tutorial would you expect the spectral lines to extend to infinity on the left part of spectrum? Explain.

A - 2 SPECTRA - INTERACTIVE TUTORIAL LECTURE

SPECTROSCOPY

ST
1

I. Discrete Spectra

- A. A hydrogen lamp is placed in front of a mask with a 1 mm slit. A prism is between the mask and a screen as shown. The pattern shown is observed on the screen.

Consider the following discussion.

Student 1: "The line at far right has the largest wavelength, which means the largest frequency. So that line corresponds to the highest energy value and represents highest energy level of hydrogen."

Student 2: "I disagree. The energy of one energy level equals hf and frequency is inversely proportional with wavelength. That means that the line at the far right corresponds to the ground energy level."

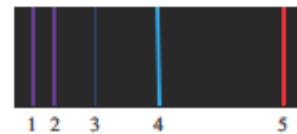
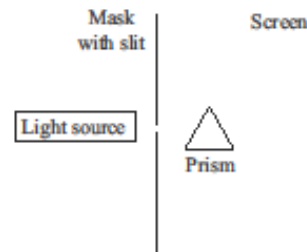

Which student, if either do you agree? Explain your reasoning.

- B. The table below shows the measured wavelengths of the lines in the spectrum above. Use the information provided to calculate the energy of the photons that form these lines. Fill in the third column of the table with the photon energies in electron volts. (Planck constant, $h = 6.62 \times 10^{-34}$ Js, speed of light, $c = 3.0 \times 10^8$ m/s, $1 \text{ eV} = 1.6 \times 10^{-19}$ J)

Line Number	Wavelength	Photon Energy (from Part B)	Formula relating photon energies to energy levels (from Part C)
2	410.2 nm		
3	434.1 nm		
4	486.1 nm		
5	656.3 nm		

C. The diagram at right shows some of the energy levels for an electron in a hydrogen atom. The energies are calculated from the Schrödinger equation.

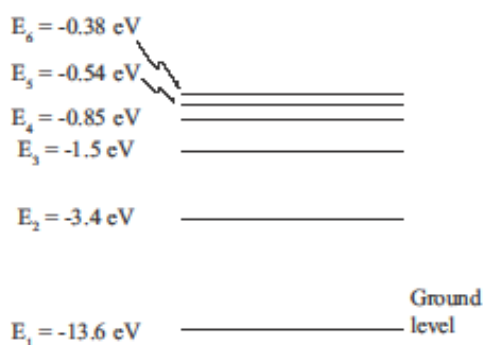

1. How are the energies in the energy level diagram algebraically related to the photon energies in the third column in the table above?

Complete the fourth column in the table in part B with a formula relating the energies from the energy level diagram and the corresponding photon energies.

(Spacing not to scale)

2. Based on the formula you found in part 1, describe what happens to the hydrogen atom when a photon is emitted. Discuss how the process is consistent with energy conservation. As part of your answer, discuss explicitly the negative signs in the energies above.

D. Refer again to the discussion among students in part A. Do you agree with your original answer? If you disagree with any of students, identify what is incorrect with their statements.

⇒ Stop here for a brief class discussion.

The lines shown in part A are in the visible part of spectra. These lines are part of what is called the Balmer series, named after Johann Balmer, a Swiss teacher who found a formula for calculating these lines. It was later recognized that the Balmer series corresponds to transitions to the second excited energy level in hydrogen ($n = 2$) from levels with n equal to three or greater. Transitions between other energy levels are found in other parts of the spectrum for hydrogen.

II. Pattern of lines in discrete spectra

A. The energy-level diagram in section 1, part C shows the lowest six energy levels for hydrogen. Calculate the ratio of E_1 to E_2 , E_1 to E_3 and E_1 to E_4 .

1. In general, how is the value of E_n algebraically related to E_1 ?
2. For a bound electron, is there any limit to the highest energy of the electron – proton system? Explain your reasoning.

Consider line 1 in the spectrum for hydrogen. The wavelength of that line equals 364.6 nm.

3. Calculate the energy of the photon that forms that line. Explain your reasoning.
4. To which transition does this line correspond? Explain.

⇒ Stop here for a brief class discussion.

B. The picture at right shows the line spectrum resulting from a particular sample of gas. (Wavelength increases to the right.)

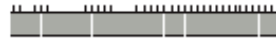

1. What is the minimum number of energy levels in each atom of a gas that could produce this spectrum? Explain.
2. Create the energy level diagram with the minimum number of energy levels that could produce these spectral lines. (The spacing between the levels should be qualitatively correct.)
3. Which transition corresponds to the line at the far right? (Imagine that all lines are formed from just these energy levels.) Explain.

C. The diagram at right shows a part of the spectrum resulting from a particular sample of gas.



1. Based on the ideas developed in this tutorial would you expect the spectral lines to extend to infinity on the left part of spectrum? Explain.
2. Based on the ideas developed in this tutorial would you expect the spectral lines to extend to infinity on the right part of spectrum? Explain.

A – 3 SPECTRA HOMEWORK – VERSION ONE

SPECTROSCOPY

Name _____

ST
HW-1

1. The energy levels for hydrogen-like atoms (*e.g.*, atoms with a single electron) can be written as $E_n = Z^2 E_0/n^2$, where E_0 is the energy of the ground level for hydrogen and Z is the number of protons in the atom.

The diagram below shows part of the line spectrum for hydrogen. (Wavelength increases to the right.)



Would you expect the corresponding lines for singly ionized helium to be *at the same places as the lines for hydrogen, further to the right, or further to the left?* Explain your reasoning.

2. The line spectrum in question 1 was obtained by placing a mask that has a wide slit (~1 mm) and a prism between a screen and a hydrogen lamp. (See figure at right.)

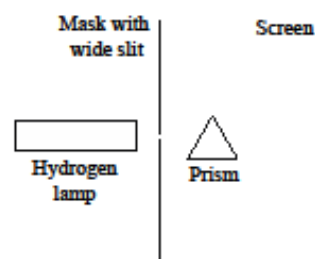

- a. Predict what you would see on the screen if the prism were removed, as shown at right. Explain briefly.

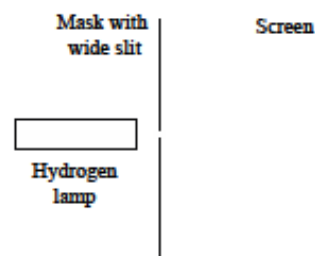

- b. Predict what you would see on the screen if the prism were put back in place and the hydrogen lamp were replaced by a green light source, as shown. Explain briefly.

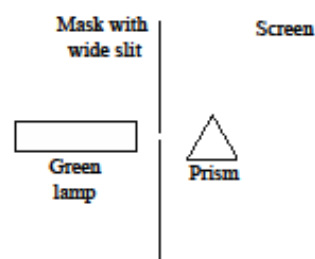

- c. Predict what you would see on the screen if the prism were now removed and replaced by a mask with a narrow slit ($\sim 1 \mu\text{m}$ wide).

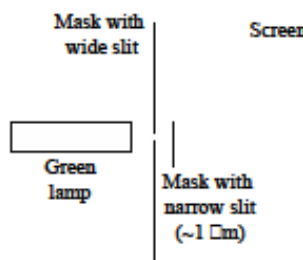

3. A glass container holds hydrogen gas at room temperature. At this temperature, most of the atoms are in the ground state. (The ground state energy of hydrogen is -13.6 eV .)

White light from an incandescent bulb is incident on the container as shown on the picture at right. (Light from this source appears continuous in the visible part of the spectrum.)

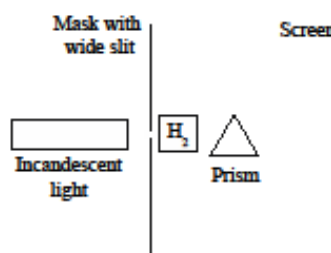

- a. It is observed that certain wavelengths are not visible in the spectrum on the screen. How can you account for this observation? Explain your reasoning.

- b. The table at right shows some missing wavelengths.

Based on the fact that the hydrogen gas is at room temperature, use the table at right to calculate a few of the energy levels for hydrogen. Explain your reasoning. Express your answers in electron-volts.

λ (nm)
121.6
102.5
97.2
94.9

A – 3 SPECTRA HOMEWORK – VERSION TWO

SPECTROSCOPY

Name _____

ST
HW-1

1. The energy levels for hydrogen-like atoms (*e.g.*, atoms with a single electron) can be written as $E_n = Z^2 E_0/n^2$, where E_0 is the energy of the ground level for hydrogen and Z is the number of protons in the atom.

The diagram below shows part of the line spectrum for hydrogen. (Wavelength increases to the right.)















Would you expect the corresponding lines for singly ionized helium to be *at the same places as the lines for hydrogen, further to the right, or further to the left?* Explain your reasoning.

2. The table below consists of 12 different experimental setups (A – L). There are four different sources of light (one for each row) and three different setups: a wide slit (1 mm wide) without a prism, a wide slit with a prism, and a narrow slit (1 μm wide) without a prism.

	Mask with wide slit (no prism)	Mask with wide slit and prism	Mask with narrow slit (no prism)
Green lamp	<p>Mask with wide slit Screen Green lamp</p> <p>A</p>	<p>Mask with wide slit Screen Green lamp Prism</p> <p>B</p>	<p>Mask with narrow slit (~ 1 μm) Screen Green lamp</p> <p>C</p>
Red lamp	<p>Mask with wide slit Screen Red lamp</p> <p>D</p>	<p>Mask with wide slit Screen Red lamp Prism</p> <p>E</p>	<p>Mask with narrow slit (~ 1 μm) Screen Red lamp</p> <p>F</p>
Incandescent lamp	<p>Mask with wide slit Screen Incandescent lamp</p> <p>G</p>	<p>Mask with wide slit Screen Incandescent lamp Prism</p> <p>H</p>	<p>Mask with narrow slit (~ 1 μm) Screen Incandescent lamp</p> <p>I</p>
Hydrogen lamp	<p>Mask with wide slit Screen Hydrogen lamp</p> <p>J</p>	<p>Mask with wide slit Screen Hydrogen lamp Prism</p> <p>K</p>	<p>Mask with narrow slit (~ 1 μm) Screen Hydrogen lamp</p> <p>L</p>

Note:: Assume for this problem that light from both the hydrogen and incandescent lamps appears white when viewed directly by eye.

2. (continued) The figure below shows the 12 patterns that would be observed on the screens in cases A-L. The center of each screen is in the center of each pattern. (Note: Patterns 2 and 6 appear identical.) Below each pattern, indicate which of the experimental setups would result in that pattern. Explain briefly. (Hint: Each pattern corresponds to one and only one experimental setup.)

<p>Pattern 1: (green)</p>  <p>Experimental setup: _____ Briefly explain.</p>	<p>Pattern 2: (white)</p>  <p>Experimental setup: _____ Briefly explain.</p>	<p>Pattern 3: (colored lines)</p>  <p>Experimental setup: _____ Briefly explain.</p>
<p>Pattern 4: (red)</p>  <p>Experimental setup: _____ Briefly explain.</p>	<p>Pattern 5: (green)</p>  <p>Experimental setup: _____ Briefly explain.</p>	<p>Pattern 6: (white)</p>  <p>Experimental setup: _____ Briefly explain.</p>
<p>Pattern 7: (green)</p>  <p>Experimental setup: _____ Briefly explain.</p>	<p>Pattern 8: (red)</p>  <p>Experimental setup: _____ Briefly explain.</p>	<p>Pattern 9: (multi-colored)</p>  <p>Experimental setup: _____ Briefly explain.</p>
<p>Pattern 10: (multi-colored)</p>  <p>Experimental setup: _____ Briefly explain.</p>	<p>Pattern 11: (red)</p>  <p>Experimental setup: _____ Briefly explain.</p>	<p>Pattern 12: (multi-colored)</p>  <p>Experimental setup: _____ Briefly explain.</p>

A - 5 SPECTRA TUTORIAL - OPTICAL SYSTEMS

A. The experimental setup shown below consists of a light source (an incandescent light bulb), a single slit with adjustable width, a glass prism and a screen. The screen is located far from the prism. When the bulb is lit, a continuous spectrum of wavelengths appears on the screen.



Three students are discussing what they need to do in order to get line spectra shown on the picture below:



Line spectrum students want to observe

Student 1: *"We need to change the width of the slit. When we change the width of the slit, we change the width of the lines. I would make slit narrower. The picture will become sharper and the lines will separate from one another."*

Student 2: *"Even if we change the width of the slit the light will fall on the prism and the prism will always refract the light in such a way that we get continuous spectrum. I would replace the prism with the diffraction grating which is a better optical instrument and helps us to see lines separated."*

Student 3: *"I would replace the light bulb with a different type of source. We need the monochromatic source of light."*

With which students, if any, do you agree? Explain your reasoning.

B. Green light from a distant point source is incident on the mask with a single slit.

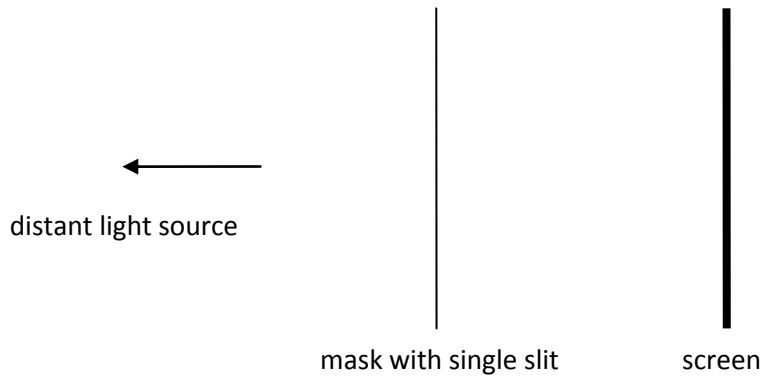

1. Predict what you are going to see on the screen when the light incidents on very narrow slit (few μm). Choose the right pattern from handout and sketch it in space provided.



Explain your reasoning.

2. Predict what you are going to see on the screen if the slit is widen to 2 mm. Choose the right pattern from handout and sketch it in space provided.

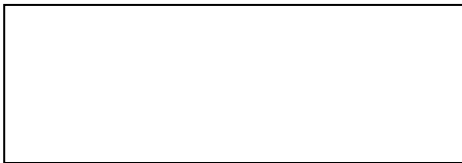

Explain your reasoning.

C. Now the white light from a distant point source is incident on the mask with a single slit (the same experimental arrangement as in part B).

1. Predict what you are going to see on the screen when the light incidents on very narrow slit (few μm). Choose the right pattern from handout and sketch it in space provided.



Explain your reasoning.

2. Predict what you are going to see on the screen when if the slit is widen to 2 mm. Choose the right pattern from handout and sketch it in space provided.



Explain your reasoning.

Ask a tutorial instructor for photographs that illustrate the patterns that appear on a distant screen when the light is incident on masks with different slit widths.

3. What can you conclude what happens when light incidents on 2 mm slit? Explain your reasoning.

D. A monochromatic green light from a distant light source is incident on a 2 mm slit. We have observed one bright spot in the middle of the screen. Predict what you are going to see on the wide screen when the prism is inserted between the slit and the screen. Choose the right pattern from handout and sketch it in space provided.

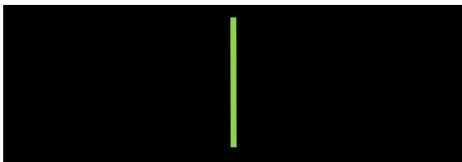

picture on the screen without a prism



picture on the screen with a prism

Explain your reasoning.

b) A white light from a distant light source incident on a 2 mm slit. We observed one bright spot in the middle of the screen. Predict what you are going to see on the wide screen when the prism is inserted between the slit and the screen. Choose the right pattern from handout and sketch it in the space provided.



picture on the screen without a prism

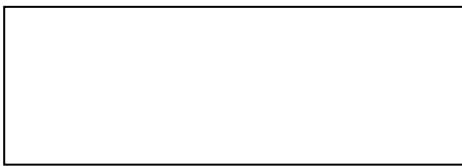

picture on the screen with a prism

Explain your reasoning.

Ask a tutorial instructor for photographs that illustrate the patterns that appear on a distant screen when the prism is put between the slit and the screen.

E. A monochromatic green light from a distant light source is incident on a 2 mm slit. We observed one bright spot in the middle of the screen. Predict what you are going to see on the screen when the diffraction grating is inserted between the slit and the screen. Choose the right pattern from handout and sketch it in space provided.



picture on the screen without a diffraction grating

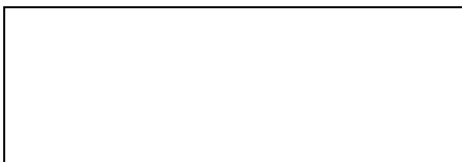

picture on the screen with a diffraction grating

Explain your reasoning.

b) A white light from a distant light source incident on a 2 mm slit. We have observed one bright spot in the middle of the screen. Predict what you are going to see on the screen when the diffraction grating is inserted between the slit and the screen. Choose the right pattern from handout and sketch it in space provided.



picture on the screen without a prism

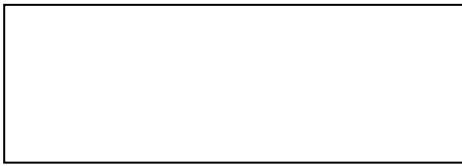

picture on the screen with a prism

Explain your reasoning.

Ask a tutorial instructor for photographs that illustrate the patterns that appear on a distant screen when the diffraction grating is put between the slit and the screen.

F. Refer again to the discussion among three students in part A. Do you agree with your original answer?

If you disagree with any of students, identify what is incorrect with their statements.

- Check your reasoning with a tutorial instructor before proceeding.

A – 6 SPECTRA TUTORIAL – CROATIAN VERSION: OPTICAL SYSTEMS

A. Eksperimentalni postav na slici sastoji se od izvora svjetlosti (obične žarulje sa volframovom žarnom niti), pukotine kojoj možemo mijenjati širinu, staklene prizme i zastora. Kada se upali žarulja, na zastoru se pojavi kontinuirani spektar (slika).



Tri studenta raspravljaju o tome koju promjenu u eksperimentalnom postavu trebaju učiniti da bi dobili linijski spektar prikazan na donjoj slici:



Linijski spektar koji student žele dobiti

Student 1: „Trebamo promijeniti širinu pukotine. Mijenjanjem širine pukotine mijenjamo širinu linija. Ja bih suzio pukotinu. Slika će postati oštrija i linije će se razdvojiti jedna od druge.“

Student 2: „Čak i ako promijenimo širinu pukotine, svjetlost će i dalje padati na prizmu, a prizma uvijek lomi svjetlost na takav način da dobijemo kontinuirani spektar. Ja bih zamijenio prizmu sa optičkom rešetkom koja je bolji optički element i omogućuje nam da linije vidimo odvojenima.“

Student 3: „Ja bih žarulju zamijenio drugim izvorom svjetlosti. Treba nam monokromatski izvor svjetlosti.“

S kojim studentom, ako i s jednim, se slažete? Objasnite svoje razmišljanje.

B. Zelena svjetlost iz udaljenog izvora pada na pukotinu (slika).

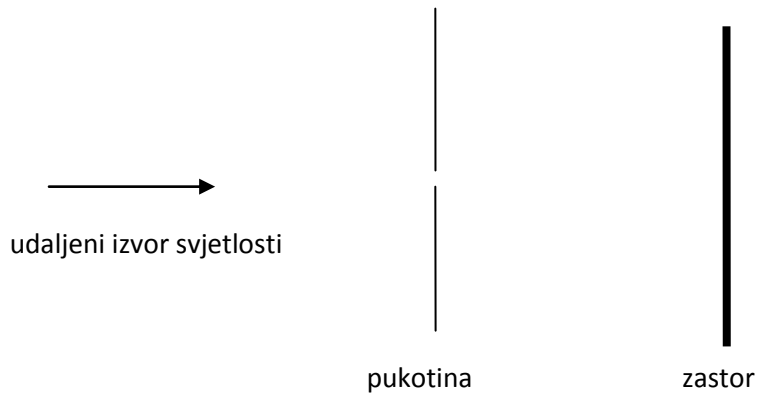

1. Što očekujete da će vidjeti na zastoru kada svjetlost padne na vrlo usku pukotinu (širine otprilike $1\ \mu\text{m}$)? Svoje predviđanje skicirajte u praznom prostoru.

Objasnite svoje razmišljanje.

2. Što očekujete da ćete vidjeti na zastoru ako pukotinu proširimo na $1\ \text{mm}$? Svoje predviđanje skicirajte u praznom prostoru.

Objasnite svoje razmišljanje.

C. Sada bijela svjetlost iz udaljenog izvora pada na pukotinu (isti eksperimentalni postav kao i u B dijelu).

1. Što očekujete da ćete vidjeti na zastoru kada bijela svjetlost padne vrlo usku pukotinu (širine otprilike $1\ \mu\text{m}$)? Svoje predviđanje skicirajte u praznom prostoru.

Objasnite svoje razmišljanje.

2. Što očekujete da ćete vidjeti na zastoru ako pukotinu proširimo na 1 mm? Svoje predviđanje skicirajte u praznom prostoru.



Objasnite svoje razmišljanje.

- Pitajte nastavnika za fotografije koje prikazuju slike koje se pojavljuju na zastoru kada svjetlost pada na pukotine različitih širina.

D. 1. Monokromatska zelena svjetlost iz udaljenog izvora pada na pukotinu širine 1 mm. Opazili smo jednu svijetlu liniju na sredini zastora. Što očekujete da ćete vidjeti na širokom zastoru kada se između pukotine i zastora umetne prizma? Svoje predviđanje skicirajte u praznom prostoru.



slika na zastoru dok nema prizme

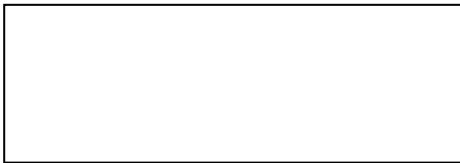

slika na zastoru kada umetnemo prizmu

Objasnite svoje razmišljanje.

2. Bijela svjetlost iz udaljenog izvora pada na pukotinu širine 1 mm. Opazili smo jednu svijetlu liniju na sredini zastora. Što očekujete da ćete vidjeti na širokom zastoru kada se između pukotine i zastora umetne prizma? Svoje predviđanje skicirajte u praznom prostoru.



slika na zastoru dok nema prizme



slika na zastoru kada umetnemo prizmu

Objasnite svoje razmišljanje.

E. 1. Monokromatska zelena svjetlost iz udaljenog izvora pada na pukotinu širine 1 mm. Opazili smo jednu svijetlu liniju na sredini zastora. Što očekujete da ćete vidjeti na širokom zastoru kada se između pukotine i zastora umetne optička rešetka? Svoje predviđanje skicirajte u praznom prostoru.

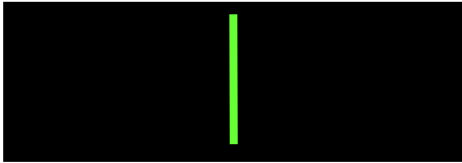

slika na zastoru bez optičke rešetke



slika na zastoru kada umetnemo optičku rešetku

Objasnite svoje razmišljanje.

2. Bijela svjetlost iz udaljenog izvora pada na pukotinu širine 1 mm. Opazili smo jednu svijetlu liniju na sredini zastora. Što očekujete da ćete vidjeti na širokom zastoru kada se između pukotine i zastora umetne optička rešetka? Svoje predviđanje skicirajte u praznom prostoru.



slika na zastoru bez optičke rešetke



slika na zastoru kada umetnemo optičku rešetku

Objasnite svoje razmišljanje.

- Pitajte nastavnika za fotografije koje prikazuju slike koje se pojavljuju na zastoru kada se prizma ili optička rešetka umetnu između pukotine i zastora.

F. Vratite se natrag na raspravu između tri studenta u A dijelu. Slažete li se sa svojim odgovorom koji ste ranije dali? Ako se ne slažete s nekim od studenata, navedite što je pogrešno u njegovoj izjavi.

A – 7 SPECTRA TUTORIAL – CROATIAN VERSION: ENERGY LEVELS

A. Vodikova lampa smještena je ispred pukotine širine 1 mm. Između pukotine i zastora nalazi se prizma kao što prikazuje slika. Na zastoru je opažen linijski spektar.

Razmotrite sljedeću raspravu između dva studenta:

Student 1: „Najdesnija linija u spektru ima najveću valnu duljinu, znači najveću frekvenciju. To znači da ta linija odgovara najvećoj energiji – ta linija predstavlja najviši energijski nivo vodika.“

Student 2: „Ne slažem se. Energija jednog energijskog nivoa iznosi hf , a frekvencija je obrnuto proporcionalna valnoj duljini. To znači da najdesnija linija odgovara osnovnom energetsom nivou.“

S kojim se studentom, ako i s jednim, slažete? Objasnite svoje razmišljanje.

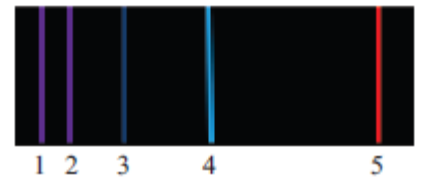
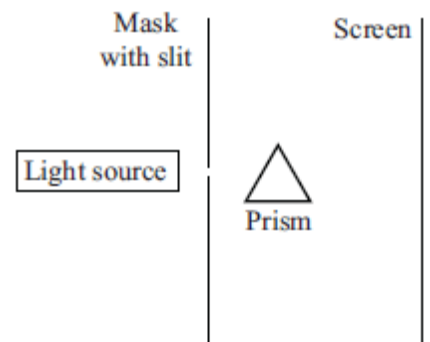

B. Valne duljine linija u gornjem spektru su izmjerene i dane u donjoj tablici. koristeći dane informacije izračunajte energije fotona koji čine te linije u elektronvoltima. (Planckova konstanta $h = 6,626 \cdot 10^{-34}$ Js, brzina svjetlosti $c = 3 \cdot 10^8$ m/s, $1\text{eV} = 1,6 \cdot 10^{-19}$ J)

BROJ LINIJE	VALNA DULJINA	ENERGIJA FOTONA (iz B dijela)	Formula koja povezuje energije fotona i energijske nivoe (upišite nakon što završite C zadatak)
2	410.2 nm		
3	434.1 nm		
4	486.1 nm		
5	656.3 nm		

C. Sljedeći dijagram prikazuje nekoliko energijskih nivoa za elektron u vodikovom atomu. Brojevi koji odgovaraju svakom energijskom nivou teorijski su izračunati iz Schroedingerove jednačbe.

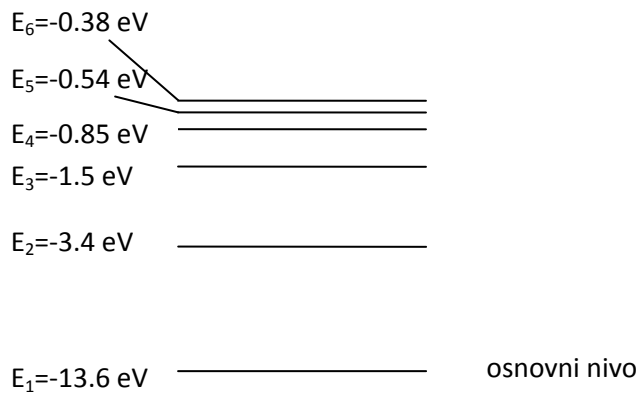

Kako su energije u energijskom dijagramu povezane s energijama fotona u trećem stupcu tablice u B dijelu? (Popunite četvrti stupac u tablici u B zadatku.)

D. Na temelju gornje jednačbe opišite što se događa s vodikovim atomom kada se emitira foton. Komentirajte da li je taj proces u skladu sa zakonom očuvanja energije. Posebno komentirajte negativan predznak koji se pojavljuje u gornjem energijskom dijagramu.

E. Vratite se natrag na raspravu između studenata u A dijelu. Slažete li se sa svojim odgovorom koji ste ranije dali? Ako se ne slažete s nekim od studenata, navedite što je pogrešno u njegovoj izjavi.

→ Provjerite svoje odgovore s nastavnikom.

Spektar prikazan na slici u A dijelu je vidljivi dio linijskog spektra vodika. Sve te linije nazivaju se Balmerovom serijom po švicarskom profesoru Johannu Balmeru koji je otkrio formulu za valne duljine tih linija. Sve linije u Balmerovoj seriji odgovaraju prijelazima sa energijskog nivoa rednog broja $n \geq 3$ na energijski nivo $n = 2$. Prijelazi između drugih energijskih nivoa nađeni su u drugim dijelovima spektra vodika.

III. Raspored linija u diskretnim spektrima

A. Energijski dijagram u C zadatku na prošloj stranici prikazuje šest najnižih energijskih nivoa vodikovog atoma.

1. Izračunajte omjer E_1/E_2 , E_1/E_3 i E_1/E_4 .

2. Kako je vrijednost E_n matematički povezana s E_1 ?

3. Postoji li limit za najvišu moguću energiju koju može imati vezani elektron (u elektron – proton sustavu)? Objasnite svoje razmišljanje.

Pogledajmo liniju u spektru vodika čija valna duljina iznosi 364.6 nm, a odgovarajuće energija fotona 3.4 eV.

4. Kojem prijelazu odgovara ta linija? Objasnite svoje razmišljanje.

5. Gdje u spektru u zadatku II. A. bi se pojavila ta linija? Objasnite svoj odgovor.

→ Provjerite svoje odgovore s nastavnikom.

B. Sljedeća slika prikazuje linijski spektar određenog uzorka plina. Valna duljina raste prema desno.

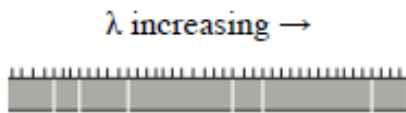

1. Koji je najmanji broj energijskih nivoa u svakom atomu plina potreban za nastanak ovog spektra? Objasnite svoj odgovor.

2. Nacrtajte energijski dijagram s najmanjim brojem energijskih nivoa za gornji spektar. (Pazite da razmaci između energijskih nivoa budu kvalitativno točni.)

3. Kojem prijelazu odgovara najdesnija linija (Pretpostavite da su sve linije koje vidite na dijagramu nastale od nacrtanih energijskih nivoa)? Objasnite svoje razmišljanje.

C. Sljedeći dijagram prikazuje dio vodikovog spektra.

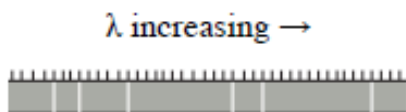

1. Na temelju ideja koje ste razvili do sada, biste li očekivali da se linije protežu beskonačno daleko u desnom dijelu spektra? Objasnite svoje razmišljanje.

2. Na temelju ideja koje ste razvili do sada, biste li očekivali da se linije protežu beskonačno daleko u lijevom dijelu spektra? Objasnite svoje razmišljanje.

A - 8 TUTORIAL HANDOUTS

HANDOUT 1

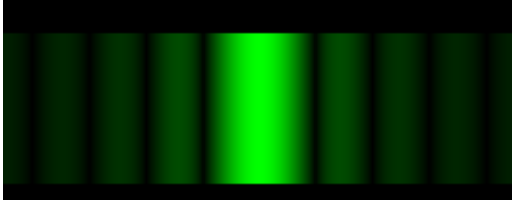

Green light, very narrow slit

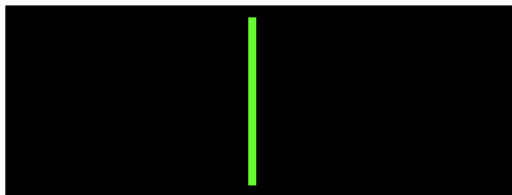

Green light, 1 mm wide slit

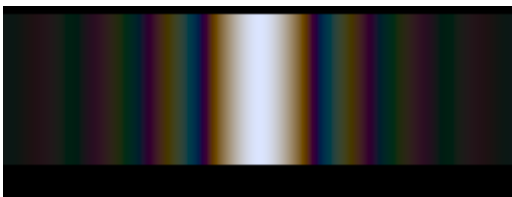

White light, very narrow slit



White light, 1 mm wide slit

HANDOUT 2



Green light, wide slit and a prism

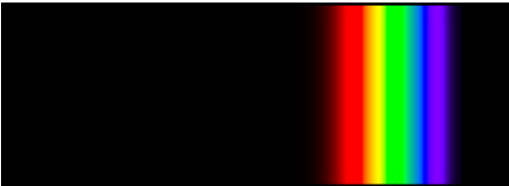

White light, wide slit and a prism

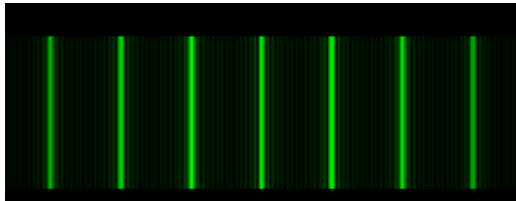

Green light, wide slit and diffraction grating

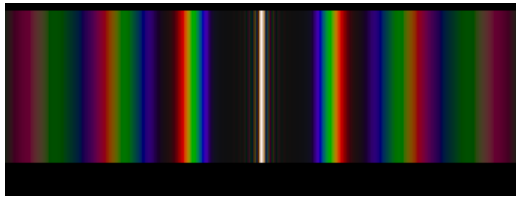

White light, wide slit and diffraction grating

STRUKTURIRANI SAŽETAK NA HRVATSKOM JEZIKU

Spektroskopija ima ključnu ulogu u modernoj fizici. Kroz povijest je opažanje diskretnih spektara dovelo do razvoja ideje o kvantizaciji energijskih nivoa u atomu i doprinijelo razvoju kvantne fizike. Danas se osnovni pojmovi vezani uz spektre uče već u srednjoj školi, kao i na uvodnim i specijaliziranim kolegijima iz fizike na fakultetima. Elektromagnetski spektri i priroda svjetlosti smatraju se najčešće poučavanom i najbitnijom temom na kolegijima iz osnova astronomije i astrofizike.

Ovaj rad izvještava o istraživanju studentskog razumijevanja atomskih spektara. Istraživanje je provedeno na dva sveučilišta: na Prirodoslovno-matematičkom fakultetu Sveučilišta u Zagrebu i na University of Washington, Seattle, USA. Cilj istraživanja bio je provjeriti koliko dobro studenti nakon klasičnih predavanja razviju funkcionalno razumijevanje spektara. U istraživanju je sudjelovalo više od 1000 studenata. Na sveučilištu u Zagrebu populacija je uključivala studente druge i četvrtе godine studija fizike. Na University of Washington populacija je uključivala studente na trećem dijelu uvodnog kolegija iz fizike. Jedan manji dio tih studenata bio je uključen u poseban „honors“ dio kolegija iz fizike, namijenjen najboljim studentima.

Uz identifikaciju i analizu specifičnih studentskih poteškoća, ovaj rad opisuje i proces razvoja, primjene i evaluacije nastavnih materijala i strategija koje mogu pomoći u razrješavanju uočenih studentskih poteškoća. Studentske su poteškoće podijeljene u dvije velike grupe, koje se djelomično preklapaju:

(A) poteškoće u povezivanju diskretnih spektara, energijskih nivoa i prijelaza

(B) poteškoće u razumijevanju uloge pojedinih dijelova eksperimentalnog postava u opažanju spektara.

Istraživanje studentskog razumijevanja atomskih spektara upotpunjeno je dodatnim laboratorijskim istraživanjem visokotlačnog izboja žive i indija. Taj dio rada daje primjer primjene klasičnih spektroskopskih metoda u istraživanju parametara visokotlačnog izboja – temperature, gustoće neutralnih čestica u plazmi i tlaka. Parametri visokotlačnog izboja žive i

indija određeni su istraživanjem oblika i širine spektralnih linija žive u vidljivom i bliskom infracrvenom dijelu spektra.

Istraživanje studentskog razumijevanja atomskih spektara zahtijeva dublje razumijevanje atomskih procesa odgovornih za nastanak atomskih spektara, kao i praktično iskustvo u radu s eksperimentalnim postavom za emisijsku spektroskopiju. Teorijski okvir i eksperimentalne metode laboratorijskog dijela istraživanja učvrstili su bazu za pitanja razvijena u svrhu istraživanja studentskog razumijevanja spektara.

Elektromagnetski spektar u nastavi se uobičajeno uvodi na uvodnim kolegijima fizike nakon što su studenti obradili teme iz fizikalne optike. Studenti tada trebaju proći put od razumijevanja vjetlosti kao elektromagnetskog vala do razvoja konceptualnog modela u kojem se svjetlost sastoji od fotona s diskretnim vrijednostima energije. Tijekom nastave studenti obično prvo vide demonstracijski pokus pri kojem bijela svjetlost upada na prizmu ili optičku rešetku, te kao rezultat daje kontinuirani spektar bijele svjetlosti na zastoru. Studentima se također prikaže i diskretni spektar žive ili vodika. Uvođenjem Balmerove, Lymanove i Pashenove serije studentima se objašnjava kako nastaje linijski spektar vodika. Uvodi se ideja da atomi u izvoru svjetlosti imaju samo diskretne, kvantizirane energijske nivoe i da je emitirana svjetlost rezultat prijelaza elektrona između dvaju energijskih nivoo. Svaki atom sadrži svoj jedinstveni skup energijskih nivoo, koji rezultira njegovim karakterističnim emisijskim spektrom.

Tijekom uvođenja pojma spektra, nastavnici pretpostavljaju da su studenti upoznati s konceptima potrebnim za daljnje razumijevanje spektara i da ih razumiju. To uključuje:

- (1) svjetlost ima valna svojstva i svaka boja svjetlosti ima svoju specifičnu valnu duljinu i frekvenciju
- (2) svjetlost se prolazeći kroz prizmu lomi pod različitim kutovima, ovisno o valnoj duljini, a ako prolazi kroz optičku rešetku dolazi do interferencije svjetlosti
- (3) svjetlost se sastoji od fotona, gdje svaki foton sadrži energiju $E_f = hc/\lambda$
- (4) linijski spektar nastaje emisijom fotona pri prijelazu elektrona s jednog energijskog nivoo na drugi ($\Delta E = E_2 - E_1$, gdje je $\Delta E = E_f$)

PRVI DIO

UVOD

Edukacijska istraživanja u fizici jako su se razvila tijekom posljednjih trideset godina. Najznačajniji rezultati edukacijskih istraživanja ukazuju na nisku efikasnost predavačke nastave i na potrebu za uvođenjem interaktivnih nastavnih metoda koje traže aktivan intelektualni angažman učenika i studenta. Kao rezultat istraživanja identificirane su brojne učeničke predkonceptije u raznim područjima fizike, što je dalo bitan doprinos razvoju novih nastavnih strategija i nastavnih materijala koji su prilagođeni sposobnostima i potrebama studenta.

Jedna od tema uvodnih kolegija fizike koja do sada nije bila dublje istražena je nastajanje atomskih spektara. Spektri se u nastavi najčešće uvode uz demonstracijski pokus, gdje se studentima pokaže da bijela svjetlost kada padne na prizmu ili optičku rešetku daje kontinuirani spektar boja. Daljnja opažanja pokazuju da svjetlost dobivena od plinskih izboja daje diskretan linijski spektar. Ti rezultati ukazuju na to da u atomu postoje diskretni energijski nivoi i da je emitirana svjetlost rezultat prijelaza između dvaju energijskih nivoa.

Glavni cilj ovog dijela istraživanja bio je ispitati do koje mjere studenti razumiju vezu između atomskih spektara i energijskih nivoa. Poseban je naglasak bio na sposobnosti studenata da prepoznaju pod kojim uvjetima nastaje diskretan linijski spektar i da povežu valnu duljinu svjetlosti u linijskom spektru s odgovarajućim prijelazom elektrona između energijskih nivoa u atomu.

Edukacijski dio rada sastoji se od osam poglavlja. Drugo poglavlje daje pregled dosadašnjih istraživanja studentskog razumijevanja tema koje su bliske spektrima, kao što su geometrijska i fizikalna optika i uvod u kvantnu mehaniku. Također su opisani i do sada razvijeni nastavni materijali povezani s nastankom spektara.

Treće poglavlje opisuje metode istraživanja i okolnosti pod kojima je istraživanje provedeno. Opisan je uzorak studenata na kojima je provedeno istraživanje i oblici nastave kojoj su oni bili izloženi.

Četvrto poglavlje opisuje istraživanje studentskog razumijevanja uloge eksperimentalnog postava u nastanku spektra i uvjeta u kojima nastaje linijski spektar. Prikazani su rezultati istraživanja i grupirane najčešće studentske poteškoće.

Peto poglavlje daje pregled studentskih poteškoća u povezivanju linija u spektru s energijskim nivoima u atomu.

Šesto i sedmo poglavlje opisuju nastavne materijale koji su razvijeni na temelju uočenih poteškoća u razumijevanju spektara. Dan je opis materijala, opis njihove primjene i prikazani rezultati studentskog razumijevanja nakon rada kroz nove nastavne materijale.

Na kraju je u zaključku dan osvrt na primijenjene metode, na uočene studentske poteškoće i na učinkovitost novih nastavnih materijala.

Strukturirani sažetak na hrvatskom jeziku dat će kratak opis studentske populacije na kojoj je provedeno istraživanje i metoda istraživanja, prikazati najčešće studentske poteškoće i ukratko opisati nastavne materijale koji su razvijeni, te evaluaciju njihove učinkovitosti. Na kraju je dan kratak zaključak.

METODE ISTRAŽIVANJA I UZORAK ISPITANIKA

Veći dio populacije na kojoj je provedeno istraživanje studentskog razumijevanja atomskih spektara opisano u ovom radu uključuje studente s University of Washington, Seattle, USA. Dio populacije činili su studenti druge godine i četvrte godine fizike na Sveučilištu u Zagrebu. Studenti s University of Washington pohađali su treću sekvencu (od tri) uvodnog kolegija fizike na kojoj se obrađuju valovi, optika i moderna fizika. Prethodno su studenti uspješno položili prva dva kolegija iz uvodnog slijeda, koji uključuju mehaniku i elektricitet i magnetizam. Većina studenta (N= 920) bila je uključena u standardnu nastavu (UW 123AC Intro), dok su ostali (N=85) bili uključeni u posebnu „honors“ komponentu kolegija za najbolje studente (UW 123B Honors).

Na sveučilištu u Zagrebu populacija je uključivala dvije grupe studenta: studente druge godine fizike koji su pohađali kolegij Opća fizika 4, koji pokriva termodinamiku i modernu fiziku (Cro Intro). Prethodno su studenti uspješno prošli kroz prva tri kolegija općih fizika koji uključuju mehaniku, elektromagnetizam, valove i optiku. Druga grupa studenta uključivala je studente četvrte godine fizike, koji su uz uvodne kolegije fizike i praktikume odslušali i kolegij kvantne mehanike (Cro Juniors).

U početnoj fazi istraživanja za identifikaciju učeničkih poteškoća korišten je polustrukturirani demonstracijski intervju. Funkcija intervjua bila je utvrditi kakve ideje studenti imaju o eksperimentalnom postavu koji se koristi za promatranje spektara i o vezi između energijskih nivoa i linija u spektru. Intervjui su provedeni s 9 studenta četvrte godine nastavnih smjerova fizike PMF-a u Zagrebu.

Na temelju poteškoća uočenih kod intervjua, konstruirano je pet pitanja višestrukog izbora u kojima se studente tražilo i objašnjenje odgovora. Pitanja su dana studentima nakon tradicionalne nastave na temu atomskih spektara.

Pitanja možemo podijeliti u dvije skupine:

1. Istraživanje studentskog razumijevanja uloge eksperimentalnog postava u formiranju spektara

2. Istraživanje studentskog razumijevanja veze između spektralnih linija i energijskih nivoa u atomu

Dva su pitanja konstruirana s namjerom da identificiraju studentske poteškoće s razumijevanjem eksperimentalnog postava u nastanku atomskih spektara. Tri su pitanja bila fokusirana na razumijevanje veze između energijskih nivoa i linija u spektru. Pitanja su prikazana na slikama 1-5.

Pitanje 1 ispituje znaju li studenti da vrsta spektra koji nastaje (kontinuirani ili diskretni) ovisi o vrsti izvora (Slika 1).

1. Eksperimentalni postav na slici sastoji se od izvora svjetlosti (obične žarulje), pukotine kojoj možemo mijenjati širinu, staklene prizme i zastora. Kada se upali žarulja, na zastoru se pojavi kontinuirani spektar. Koju od sljedećih promjena u eksperimentalnom postavu je potrebno učiniti da bi na zastoru vidjeli linijski spektar?

- Zamijeniti žarulju sa drugim izvorom svjetlosti.
- Promijeniti širinu pukotine.
- Prizmu zamijeniti sa optičkom rešetkom.
- Promijeniti udaljenost između prizme i zastora.
- Maknuti prizmu.

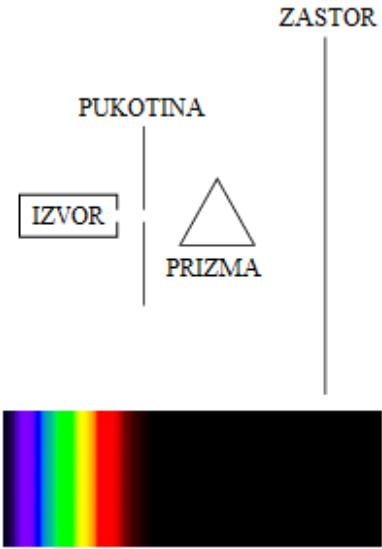

Slika 1. Pitanje 1

Pitanje 2 (Slika 2) ispituje što će se dogoditi s linijskim spektrom ako iz eksperimentalnog postava uklonimo prizmu. Studenti bi trebali primijetiti da ukoliko nema prizme nastaje samo jedna svijetla pruga na sredini zastora, jer više nema disperzivnog elementa koji razdvaja različite valne duljine svjetlosti.

2. Donja slika prikazuje dio diskretnog spektra koji se pojavljuje na vrlo velikom zastoru (boje nisu prikazane). Spektar je dobiven pomoću eksperimentalnog



Što će se dogoditi ako maknemo prizmu?

- a) Linije će biti gušće raspoređene.
- b) Linije će ostati jednake.
- c) Linije će ostati na istom mjestu, ali će sve biti iste boje.
- d) Linije će nestati i zamijenit će ih jedna svijetla pruga na sredini zastora.
- e) Linije će nestati i zamijenit će ih svijetla pruga koja se nalazi na zastoru u području gdje su se do tada nalazile linije.

Slika 2. Pitanje 2 – Što će se dogoditi sa linijskim spektrom ako maknemo prizmu

Pitanja 3 – 5 odnose se na vezu između linija u spektru i energijskih nivoa. U pitanju 3 studentima je prikazana skica energijskih nivoa nepoznatog atoma i oni trebaju odrediti koliki je maksimalni broj linija koje možemo opaziti. Dva energijska nivoa daju jedan prijelaz, tj. jednu liniju, treći dodaje još dva prijelaza, a četvrti još 3, što ukupno daje 6 spektralnih linija. Dok pitanje 3 daje prikaz energijskih nivoa i traži broj spektralnih linija, pitanja 4 i 5 daju prikaz spektralnih linija i traže studente da ih povežu sa energijskim nivoima. U pitanju 4 studente se pita koja linija odgovara prijelazu između dvaju najbližih energijskih nivoa. Budući da dva najbliža energijska nivoa znače prijelaz s najmanjom razlikom u energiji, a najmanja energija odgovara najvećoj valnoj duljini, crvena linija pod brojem 11 odgovara prijelazu između dvaju najbližih nivoa. U petom pitanju ponovno je prikazano 11 linija, ali se sada tražio najmanji broj energijskih nivoa koji ih može proizvesti. Za njihov nastanak potrebno je najmanje 6 energijskih nivoa.

3. Slika prikazuje nekoliko najnižih **energijskih nivoa** nepoznatog atoma.

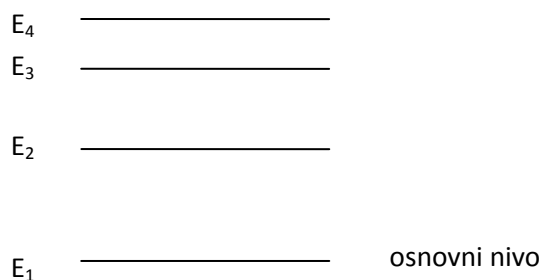

Koliki je maksimalan broj spektralnih linija koje možemo opaziti samo od ovih energijskih nivoa?

Slika 3. Pitanje 3 – veza između energijskih nivoa i broja linija u spektru

4. Sljedeći dijagram prikazuje spektar nekog plina.

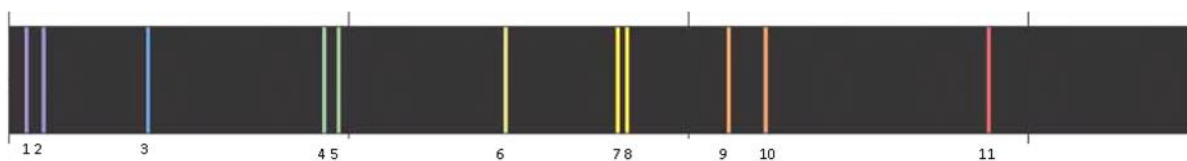

Koja linija (ili linije) odgovara prijelazu između dva najbliža energijska nivoa?

- a) 1
- b) 1 i 2
- c) 7 i 8
- d) 10 i 11
- e) 11

Slika 4. Pitanje 4 – prijelaz između dvaju najbližih energijskih nivoa

5. Sljedeći dijagram prikazuje spektar nekog plina.

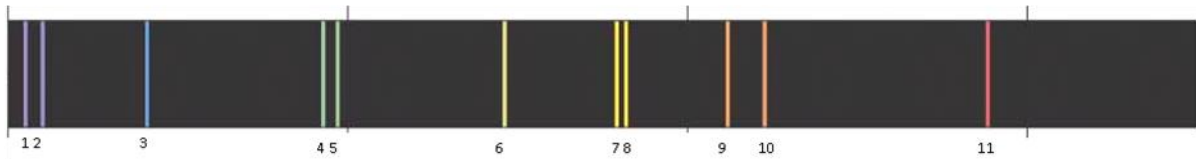

Koji je najmanji broj energijskih nivoa u svakom atomu plina potreban da bi nastao ovakav spektar?

- a) 5
- b) 6
- c) 8
- d) 10
- e) 11

Slika 5. Pitanje 5 – veza između linija u spektru i energijskih nivoa

Osim pitanja 3 koje je dano samo studentima na uvodnom kolegiju fizike na University of Washington, sva ostala pitanja dana su i studentima u Zagrebu i studentima na University of Washington. Rezultati i specifične studentske poteškoće prikazani su u sljedećem poglavlju.

REZULTATI I SPECIFIČNE STUDENTSKE POTEŠKOĆE

Već tijekom demonstracijskih intervjua primijećeno je da studenti imaju problema s prepoznavanjem uloge pojedinih dijelova eksperimentalnog postava u formiranju spektara. U studentskih odgovorima na pitanja 1 i 2, pokazalo se koliko su ti problemi učestali. Tablice 1 i 2 prikazuju postotke točnih odgovora na ta pitanja, kao i najčešće pogrešne odabire studenata.

Tablica 1. Pregled studentkih odgovora na pitanje 1.

	CRO INTRO 2011 N = 36	UW123A PROLJEĆE 2010 N = 127	UW123A ZIMA 2011 N = 230	UW123AC PROLJEĆE 2011 N = 300	UW123B PROLJEĆE 2010 N = 48	UW123B PROLJEĆE 2011 N = 37
Širina pukotine	35%	39%	36%	34%	25%	7%
Optička rešetka	35%	61%	56%	47%	50%	28%
Zamjena izvora	45%	53%	60%	64%	69%	44%
Udaljenost od prizme do zastora	20%	29%	36%	22%	4%	4%
Uklanjanje prizme	15%	50%	41%	21%	0%	7%
Točno – SAMO ZAMJENA IZVORA	30%	6%	17%	29%	27%	30%

Tablica 2. Pregled studentskih odgovora na pitanje 2.

	UW 123 N = 330	CRO INTRO N = 50	CRO JUNIORS N = 62
Linije će biti gušće raspoređene	12%	36%	5%
Linije će ostati na istom mjestu, ali će sve biti iste boje.	10%	10%	13%
Linije će nestati i zamijenit će ih jedna svijetla pruga na sredini zastora.	45%	45%	70%

Pitanja 3 – 5 ispitivala su sposobnost studenata da povežu linije u spektru s prijelazima između energijskih nivoa. U tablici 3 dan je pregled postotaka točnih odgovora na sva tri pitanja, dok je u tablicama 4 i 5 prikazana raspodjela studentskih odgovora po pojedinim distraktorima. Vidljivo je da je oko 50% studenata povežalo jednu liniju u spektru s jednim energijskim nivoom u energijskom dijagramu.

Tablica 3. Pregled postotaka točnih odgovora na pitanja 3 – 5 za različite skupine studenata.

	UW123AC Proljeće 2011	UW123AC Zima 2011	UW 123A Jesen 2009	CRO INTRO 2010, 2011	UW123B HONORS 2010, 2011	CRO JUNIORS 2010
Broj studenata	300	230	190	92	71	62
Pitanje 3	55%		55%			
Pitanje 4	20%	15%		10%	30%	35%
Pitanje 5	30%	20%		15%	45%	50%
Pitanja 4 i 5	15%	10%		10%	20%	30%

Tablica 4. Pregled raspodjele studentskih odgovora na pitanje 4 po distraktorima za različite grupe studenata.

	CRO INTRO 2010 N = 50	CRO INTRO 2011 N = 36	UW123A ZIMA 2011 N = 230	UW123AC PROLJEĆE 2011 N = 300	UW123B PROLJEĆE 2010 N = 48	UW123B PROLJEĆE 2011 N = 37	CRO JUNIORS 2010 N = 62
1		3%	3%	5%	6%	11%	2%
1 i 2		3%	11%	9%	6%	5%	3%
7 i 8		42%	60%	52%	40%	38%	45%
10 i 11		0%	5%	7%	8%	8%	3%
11	10%	22%	13%	22%	27%	38%	35%

Tablica 5. Pregled raspodjele studentskih odgovora na pitanje 5 po distraktorima za različite grupe studenata

	CRO INTRO 2010 N = 50	CRO INTRO 2011 N = 36	UW123A ZIMA 2011 N = 230	UW123AC S PROLJEĆE 2011 N = 300	UW123B PROLJEĆE 2010 N = 48	UW123B PROLJEĆE 2011 N = 37	CRO JUNIORS 2010 N = 62
5		8%	12%	16%	19%	11%	
6	10%	20%	18%	32%	42%	46%	50%
8		0%	5%	5%	2%	5%	
10		0%	7%	5%	4%	0%	
11		30%	54%	41%	21%	35%	

IDENTIFIKACIJA STUDENTSKIH POTEŠKOĆA VEZANIH UZ RAZUMIJEVANJE ULOGE EKSPERIMENTALNOG POSTAVA U FORMIRANJU SPEKTARA

Većina studenata imala je značajnih poteškoća u odgovaranju na pitanja u ovom istraživanju. Studentska obrazloženja pružila su uvid u njihovo razmišljanje i na temelju tih obrazloženja studentske poteškoće su organizirane i grupirane. Pojedine kategorije studentskih poteškoća uzajamno se ne isključuju, te se individualni studentski odgovori mogu interpretirati na više načina.

POTEŠKOĆE POVEZANE S ULOGOM PRIZME

U pitanjima 1 i 2 studenti su pitani što će se dogoditi kada maknemo prizmu iz eksperimentalnog postava. U pitanju 1 spektar je bio kontinuiran prije uklanjanja prizme; u

pitanju 2 početni je spektar bio diskretan. U pitanju 1 studenti su također pitani o utjecaju udaljenosti između prizme i zastora na promatrani spektar. Odgovori na ta pitanja dali su nam uvid u studentsko razmišljanje o različitim vrstama spektara i ulozi prizme. Slijedi pregled najčešćih uočenih studentskih poteškoća.

a) Prizma uvijek daje kontinuirani spektar

Na temelju studentskih obrazloženja uz pitanje 1, može se zaključiti da dio studenata vjeruje da, neovisno o izvoru svjetlosti, prolaskom svjetlosti kroz prizmu uvijek nastaje kontinuirani spektar.

“Prizma će i dalje formirati kontinuirani spektar.” (UW Intro)

“Spektar stvara prizma, a ne izvor svjetlosti” (UW Intro)

Oko 40 % studenata napravilo je ovu pogrešku. Neki su tu vrstu razmišljanja konzistentno ponavljali kroz čitavo pitanje 1. Na primjer, neki su studenti točno zaključili da spektar ostaje kontinuiran ako se promijeni širina pukotine, no njihova obrazloženja bazirala su se na razmišljanju o prizmi, a ne o izvoru koji daje kontinuirani spektar.

b) Spektralne su linije uvijek vidljive

Najčešći netočan odgovor na pitanje 2 uključivao je odgovor da će spektralne linije na zastoru ostati vidljive i ako maknemo prizmu. Većina studenata to je dodatno pojasnila izjavom da će linije samo biti bliže jedna drugoj. Neki su studenti linije povezali s ogibom svjetlosti, dok su drugi vjerovali da su linije uvijek vidljive ako svjetlost dolazi od ioniziranog plina.

„Prizma skreće svjetlost koja je došla kroz pukotinu. Zato se svjetlost različitih frekvencija razdvaja ovisno o frekvenciji. Kada se makne prizma, to razdvajanje i dalje postoji, samo je manje vidljivo, jer prizma samo dodatno razdvoji različite frekvencije.” (UW Intro)

POTEŠKOĆE VEZANE UZ PUKOTINU I/ILI OPTIČKU REŠETKU:

U pitanju 1, dvije ponuđene promjene u eksperimentalnom postavu uključivale su: (1) sužavanje pukotine koja se nalazi ispred prizme i (2) zamjenu prizme optičkom rešetkom. U oba je slučaja velik broj studenata odgovorio da je ogib odgovoran za formiranje linijskog spektra od izvora koji daje kontinuirani spektar.

a) Brkanje linijskog spektra i ogibne slike

Dio studenta neispravno je zaključio da će obje gore navedene promjene od kontinuiranog spektra stvoriti diskretni. Čini se da dio studenta ne razlikuje diskretni spektar od ogibne slike.

“Optička rešetka će uzrokovati interferenciju koja je onda ogibna slika.” (UW Intro)

„Optička rešetka daje minimume i maksimume umjesto kontinuirane raspodjele.“ (UW Intro)

Ovi su se studenti ispravno prisjetili da se ogibna slika koju stvara svjetlost nakon što prođe kroz optičku rešetku sastoji od tamnih i svijetlih pruga, ali su netočno taj uzorak povezali s diskretnim spektrom.

b) Kontinuirani spektar se sastoji samo od određenih boja

Odgovori nekih studenata na pitanje 1 sugeriraju da oni smatraju da se kontinuirani spektar sastoji samo od određenih valnih duljina. Oni smatraju da će se sužavanjem pukotine ili zamjenom prizme s optičkom rešetkom „raširiti snop svjetlosti“, te da će zato nastati diskretni spektar.

“Sužavanje pukotine će raširiti snop svjetlosti, a to će raširiti sliku na zastoru i stvoriti diskretni spektar” (UW Intro)

“Optička će rešetka stvoriti diskretni spektar, jer se ona sastoji od mnoštva pukotina i razdvaja različite valne duljine (UW Intro)

„Što je pukotina uža, to je veća udaljenost između minimuma i maksimuma, što daje linijski spektar. Ako bismo pak proširili pukotinu, spektar će ostati kontinuiran.“ (Cro Intro)

Izgleda da određeni broj studenata smatra da se početni, kontinuirani spektar sastoji od konačnog broja pruga, gdje svaka pruga ima svoju specifičnu boju (zelenu, plavu, crvenu...). Proširivanje slike na zastoru tada daje konačan broj pruga, gdje svaka pruga odgovara određenoj valnoj duljini.

c) Monokromatski izvori svjetlosti daju linijski spektar

Oko 20% studenata smatra da će se na zastoru formirati diskretan spektar, ako zamijenimo izvor svjetlosti monokromatskim izvorom.

“To rezultira linijskim spektrom, jer sada imamo samo jednu valnu duljinu umjesto kombinacije valnih duljina (kao kod žarulje)” (UW Honors)

„Zamjena žarulje monokromatskim izvorom svjetlosti dat će diskretan spektar na zastoru, jer će sada biti prisutna samo jedna valna duljina umjesto kombinacije valnih duljina.“ (UW Intro)

Iako će monokromatski izvor dati diskretan uzorak (na zastoru će biti vidljiva samo jedna linija), čini se da ovi studenti ne razumiju što to znači diskretan spektar i kako on nastaje.

IDENTIFIKACIJA STUDENTSKIH POTEŠKOĆA U RAZUMIJEVANJA VEZE IZMEĐU SPEKTRALNIH LINIJA I ENERGIJSKIH NIVOA U ATOMU

Već tijekom intervjua opaženo je da studenti ne razumiju vezu između spektralnih linija i energijskih nivoa, te da vrlo često povezuju jednu liniju u spektru s jednim energijskim nivoom, a ne s prijelazom između dvaju energijskih nivoa. Pitanja 3 – 5 otkrila su niz netočnih ideja koje studenti imaju o vezi između energijskih nivoa i spektralnih linija. Studentske poteškoće su organizirane u kategorije da bi se lakše uočile i identificirale pogreške u studentskom razmišljanju.

a) Povezivanje jedne linije u spektru s jednim energijskim nivoom

Najčešće pogreška koju su studenti napravili bilo je povezivanje jedne linije u spektru sa samo jednim energijskim nivoom. Otprilike polovica studenata napravila je tu pogrešku. Na

primjer, u pitanju 5, polovica studenta rekla je da je potrebno 11 energijskih nivoa da bi nastalo 11 linija u diskretnom spektru.

„Svaki energijski nivo stvara svoju emisijsku liniju. Ima 11 linija, što znači da je potrebno 11 energijskih nivoa.“ (UW Honors)

“Svakoj liniji odgovara jedan energijski nivo.” (Cro Junior)

Ta pogreška bila je uočljiva i u studentskim odgovorima na pitanje 4. Između 40% i 60% studenta povezalo je dvije najbliže linije u spektru (7 i 8) s prijelazom između dvaju najbližih energijskih nivoa.

„Razmak između linija 7 i 8 je najmanji, zato su njihovi energijski nivo najbliži jedan drugome.“ (UW Intro)

b) Izjednačavanje energije fotona s energijom u energijskom dijagramu

Podskup studenata koji su napravili prethodnu pogrešku smatra da je energija fotona koji čine svaku spektralnu liniju ($h\nu$) jednaka energiji jednog energijskog nivoa.

„ $E = h\nu$. To znači da jedna valna duljina odgovara jednom energijskom nivou, tj. jedan energijski nivo je jedan foton s definiranom energijom.“ (Cro Junior)

c) Promatranje određenog broja boja u spektru, a ne ukupnog broja linija

Prilikom odgovaranja na pitanje 5, neki su studenti brojali različite boje u spektru, a ne linije. Oni su prepoznali da se spektar sastoji od 11 linija, ali samo 6 različitih boja. Koristeći broj boja došli su do točnog rezultata za broj energijskih nivoa, naravno uz pogrešno zaključivanje.

„Brojeći grupe boja u spektru možemo odrediti broj energijskih nivoa potrebnih da nastane spektar.“ (UW Honors)

„Broj različitih boja (6) je broj energijskih nivoa (6).“ (UW Intro)

d) Osnovni energijski nivo nije energijski nivo

15 % studenata je na pitanju 5 odabralo netočan odgovor da je najmanji broj energijskih nivoa potreban za nastanak 11 spektralnih linija 5, a ne 6. Većina njih je svoje obrazloženje započela točno, brojeći spektralne linije koje nastaju prijelazima iz prvog pobuđenog u osnovno stanje, iz drugog pobuđenog u prvo pobuđeno i osnovno stanje, itd... Prepoznali su da je će 4 pobuđena energijska nivoa dati 10 spektralnih linija, te da je za 11 linija potrebno minimalno 5 pobuđenih energijskih nivoa. Međutim, zatim su zaključili da je potrebno 5 energijskih nivoa. Neki su eksplicitno napisali da se osnovni energijski nivo ne treba brojati.

„Prvi nivo je osnovno stanje, pa se on ne broji.“ (UW Intro)

e) Uvjerjenje da atomski prijelazi uvijek uključuju osnovni energijski nivo

Oko 10% studenta je na pitanje 3 odgovorilo da od 4 energijska nivoa možemo opaziti maksimalno 3 spektralne linije (a ne 6). Većina tih studenata smatrala je da su mogući samo prijelazi na osnovni energijski nivo. Sljedeća slika najbolje opisuje ovu poteškoću.

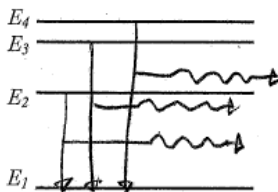

Slika 6 Primjer studentskog odgovora

f) Pogrešan model za emisiju fotona

Oko polovice studenata je na pitanje 3 točno odgovorilo da 4 energijska nivoa daju 6 mogućih prijelaza. Međutim, samo je 15 % studenata dalo potpuna i točna objašnjenja u kojima su opisali emisiju svjetlosti kao rezultat prijelaza elektrona s višeg na niži energijski nivo. Većina obrazloženja bila je nepotpuna. Neki studenti nisu naveli što to prelazi s jednog

energijskog nivo na drugi, dok su drugi netočno identificirali prijelaze fotona, ili čak samih energijskih stanja.

„Maksimalni broj spektralnih linija je 6 jer foton može skočiti s bilo kojeg na bilo koji energijski nivo.“ (UW Intro)

g) Zamjena i miješanje povezanih koncepata

Iz studentskih je odgovora uočljivo da studenti termine *spektralna linija*, *energija fotona* i *energijski nivo* koriste neispravno i s nerazumijevanjem. Mnoga obrazloženja ukazuju na njihovo slabo razlikovanje ovih međusobno povezanih koncepata. Na primjer, studenti su opisivali prijelaze između spektralnih linija, umjesto između energijskih nivoa. Takva su obrazloženja često bila povezana s netočnim odgovorima, što ukazuje na činjenicu da su studenti imali nekoliko različitih poteškoća istovremeno.

„Linije 7 i 8 su najbliže jedna drugoj, pa su prijelazi između tih dviju energija najbliži.“ (UW Intro)

„One (linije 7 i 8) su najbliže jedna drugoj, pa je potrebno manje energije za prijelaz između 7 i 8 i 8 i 7.“ (UW Intro)

OPĆENITE POTEŠKOĆE

Opisane specifične studentske poteškoće ukazale su na dva veća problema. Pogreške koje su studenti napravili ukazuju na to da velik broj njih nije prepoznao da su diskretni emisijski spektri povezani s izvorom svjetlosti koja se sastoji samo od određenih valnih duljina. Nadalje, iako se emisijski spektri uvode da bi pomogli studentima da se upoznaju s diskretnim energijskim nivoima u atomu i prijelazima između njih, mali broj studenata razumije vezu između tih ideja.

a) Uvjerenje da bilo koji izvor daje diskretan spektar

Kao što je već opisano, velik broj studenta smatra da se kontinuirani i diskretni spektar mogu transformirati jedan u drugi ako se promijene optički elementi u eksperimentalnom postavu koji služe za opažanje spektara. Značajan broj studenata odabrao je svaki od ponuđenih odgovora u pitanju 1 (promjena širine pukotine, zamjena prizme optičkom rešetkom, promjena udaljenosti između prizme i zastora) kao način kako dobiti diskretan spektar od izvora bijele svjetlosti. Studentski odgovori ukazali su na niz poteškoća povezanih s razumijevanjem uloge pojedinih optičkih elemenata u eksperimentalnom postavu. Na mnogo općenitijoj razini, odgovori su ukazali na to da studenti ne razumiju da je diskretan linijski spektar povezan s diskretnim izvorom svjetlosti.

b) Nepovezivanje linijskog spektra s atomskim prijelazima

Tijekom intervjua sa studentima četvrte godine fizike u Zagrebu, uočeno je da su studenti linije u spektru žive pripisivali optičkim elementima u eksperimentalnom postavu. Pitanja koja su bila dana većem broju studenata u pismenom obliku pokazala su da većina studenta ne povezuje linije u diskretnom spektru s prijelazima između energijskih nivoa u atomu.

TUTORIJALI I NJIHOVA EVALUACIJA

Rezultati istraživanja studentskog razumijevanja spektara korišteni su pri razvijanju nastavnih materijala namijenjenim uvodnim kolegijima fizike na fakultetu. Materijali su napravljeni sa svrhom da pomognu studentima u savladavanju poteškoća u razumijevanju procesa nastanka spektara i u razvijanju funkcionalnog razumijevanja spektara.

Razvijeni nastavni materijali namijenjeni su primjeni na uvodnim kolegijima fizike na sveučilištima. Različita sveučilišta imaju različite modele uvodnih fizika, no u većini slučajeva uvodni kolegij fizike sastoji se od predavanja i vježbi koje nadopunjuju predavanja. Tutorijali, nastavni materijali koje je razvila grupa za edukacijsku fiziku na University of Washington, služe kao model za razvoj nastavnih materijala opisanih u ovom doktoratu. Tutorijali se na University of Washington primjenjuju već godinama i pokazali su se efikasima u pomaganju studentima u razvijanju razumijevanja fizikalnih koncepata i savladavanju studentskih poteškoća. Najčešći format nastave u kojima se tutorijali primjenjuju je grupni rad, pri kojem 24 – 30 studenata podijeljenih u grupe po četvero ili petero zajednički prolaze kroz nastavne materijale, dok ih asistenti obilaze i, postavljajući im pitanja, pomažu razviti razumijevanje određene teme iz fizike. Svakom tutorijalu obično prethodi pretest, koji studentima i nastavnicima omogućuje da dobiju uvid u postojeće konceptualne poteškoće studenata. Nakon tutorijala slijedi posttest koji služi za evaluaciju nastavnih materijala i daje uvid u studentsko razumijevanje nakon primjene tutorijala.

Koristeći informacije o studentskim poteškoćama prikupljene u istraživanju studentskog razumijevanja spektara, razvijena su dva tutorijala vezana uz formiranje atomskih spektara. Tutorijali su prikazani u cijelosti u Dodacima 6 i 7.

Posttest pitanja koristila su se za evaluaciju nastavnih materijala. U pitanjima su ispitivani isti koncepti kao i u pretest pitanju, ali u malo drugačijem kontekstu, tako da studenti ne bi samo memorirali odgovore. U Tablici 6 prikazani su i sumirani odgovori na pitanje o minimalnom broju energijskih nivoa potrebnom da bi nastao linijski spektar, te su rezultati uspoređeni s rezultatima odgovora na slično pitanje iz pretesta.

Tabela 6 Postotak točnih odgovora na posttest pitanje i usporedba s predtest rezultatima

	UW Honors N = 52 NAKON TUTORIJALA	CRO Intro N = 100 NAKON TUTORIJALA	UW Regular N = 177 NAKON TUTORIJALA	UW Honors N = 37 NAKON TUTORIJALA	UW Regular N = 174 NAKON TUTORIJALA	ALL INTRO STUDENTS N = 700 PRETEST	Cro Juniors
Pitanje:	Posttest 1	Posttest 1	Posttest 2	Posttest 2	Posttest 3	Predtest	Predtest
Postotak točnih odgovora	95 %	85 %	90 %	95 %	85 %	30 %	50 %

ZAKLJUČAK

Glavni cilj istraživanja opisanog u ovom doktoratu bio je istražiti u kojoj mjeri studenti razumiju vezu između energijskih nivoa i atomskih spektara. Poseban naglaska bio je i na istraživanju sposobnosti studenta da prepoznaju u kojim uvjetima nastaju diskretni spektri i da povežu valnu duljinu linije u spektru s prijelazom elektrona između energijskih nivoa u atomu.

Opisano istraživanje ukazuje da većina studenata ne uspijeva razviti funkcionalno razumijevanje spektara kroz tradicionalnu predavačku nastavu. Pronađeni su neki ozbiljni konceptualni problemi u zaključivanju koji su bili prisutni čak i nakon nastave. Standardna nastava nije razriješila studentske poteškoće. Mnogi studenti nisu prepoznali kako nastaje linijski spektar. Mnogi ispitanici nisu povezali diskretne spektre s određenim vrstama izvora svjetlosti, nego su smatrali da je linijski spektar rezultat prolaska svjetlosti kroz različite optičke instrumente.

Tijekom istraživanja postalo je jasno da mnogi studenti nepotpuno ili pogrešno razumijevaju kako su energijski nivoi i prijelazi elektrona među njima povezani s diskretnim linijskim spektrima. Polovica studenata tijekom intervjua nije niti spomenula energijske nivoe dok su objašnjavali nastanak linijskog spektra. Kad su bili upitani o povezanosti energijskih nivoa i spektralnih linija, mnogi studenti nisu uspjeli prepoznati da je svaka spektralna linija rezultat prijelaza elektrona između dvaju energijskih nivoa. Većina je povezala jednu spektralnu liniju s jednim energijskim nivoom. Čak i studenti koju su prepoznali da pojedina spektralna linija jest povezana s dva energijska nivoa, često nisu imali točan model za emisiju svjetlosti. Mnogi nisu uzeli u obzir osnovni energijski nivo kao energijski nivo ili su pak smatrali da su svi prijelazi povezani samo s osnovnim energijskim nivoom. Podjednake poteškoće primijećene su kod studenata Sveučilišta u Zagrebu kao i kod studenata na University of Washington. Štoviše, pogreške nisu bile ograničene samo na studente na uvodnim kolegijima fizike, već su iste pogreške primijećene i kod studenata na višim godinama studija fizike.

Sve u svemu, zaključili smo da u razmišljanju o diskretnim linijskim spektrima postoje poteškoće za sve studente na svim nivoima. Bilo bi za očekivati da studenti koji su završili kolegij kvantne mehanike ne bi trebali imati problema u povezivanju linija u spektru s

prijelazima između energijskih nivoa. Međutim, zadaci upotrijebljeni u ovom istraživanju bili su izazov čak i za te studente. Rezultati istraživanja su pokazali potrebu za nastavnim materijalima: (1) koji pomažu prevladati poteškoće identificirane u ovom istraživanju i (2) će pomoći studentima povezati formalizam koji su naučili tijekom nastave s opažanjima spektara u laboratoriju.

Razvijeni su nastavni materijali koji pomažu studentima da ispune praznine u razumijevanju koje su identificirane tijekom istraživanja. Zadaci koji naglašavaju specifične poteškoće pokazali su se korisnima u pomaganju studentima da iste prevladaju. U cilju ocjenjivanja efikasnosti nastavnih materijala razvijena su posttestna pitanja koja traže studente da primijene koncepte i ideje koje su proučavali. Posttestna pitanja odnose se na situacije koje se razlikuju od onih obrađenih u nastavnim materijalima. Rezultati su pokazali veliki napredak kod studenata u razumijevanju atomskih prijelaza nakon primjene tutorijala. Problemi u razumijevanju uloge različitih dijelova eksperimentalnog postava u nastanku spektara ostali su prisutni čak i nakon tutorijala. Tom dijelu tutorijala potrebno je daljnje usavršavanje.

Rezultati posttesta pokazuju da se tradicionalna nastava može modificirati tako da poboljša studentsko razumijevanje ovako važne teme.

EKSPERIMENTALNI DIO

UVOD

Ovaj dio rada odnosi se na istraživanje visokotlačnog metal-halogenog izboja u kojem su glavne komponente atomi žive i indija. U istraživanju su korištene spektroskopske metode, koje su najčešće korištene metode u istraživanju plazme jer analiziraju svjetlost bez da djeluju na plazmu te na taj način ne utječu na ispitivani uzorak.

Istraživanje oblika i širine spektralnih linija koje zrači plazma daje informaciju o osnovnim parametrima plazme kao što su temperatura, tlak, koncentracija čestica u plazmi i atomskim interakcijama. U ovom istraživanju parametri plazme su određeni mjerenjem apsolutnih lateralnih intenziteta optički tankih živinih linija. Lateralni intenziteti su korištenjem Abelove transformacije pretvoreni u radijalne emisijske koeficijente. Relativni intenziteti linija iz visokotlačnog izboja uspoređeni su sa zračenjem referentnog niskotlačnog izboja žive poznate gustoće zračenja u svakoj liniji vidljivog i bliskog infracrvenog dijela spektra. Gustoća atom žive u osnovnom stanju određena je pomoću rezonantnog širenja u vidljivom i infracrvenom dijelu spektra.

Prvi dio rada sastoji se od šest poglavlja. Drugo poglavlje opisuje različite vrste izvora svjetlosti koji se koriste u nastavi u demonstraciji kontinuiranog i linijskog spektra, kao i u laboratorijskim istraživanju.

U trećem poglavlju opisani su mehanizmi širenja spektralnih linija. Detaljnije je opisano sudarno širenje spektralnih linija, kao i eksperimentalni postupak provjere samoapsorpcije spektralnih linija, tj. postupak za provjeru jesu li promatrane spektralne linije optički tanke. U ovom poglavlju također su prikazani postupci za određivanje gustoće čestica žive i elektronske temperature.

U četvrtom poglavlju opisana su osnovna svojstva metal-halogenih izboja.

Peto poglavlje odnosi se na određivanje parametara visokotlačnog izboja. Opisan je eksperimentalni postav, način određivanja instrumentalne funkcije monokromatora, napravljena usporedba intenziteta linije 577 nm iz visokotlačnog i referentnog niskotlačnog izboja žive, te su prikazani rezultati određivanja parametara plazme.

U šestom poglavlju dana je rasprava dobivenih eksperimentalnih vrijednosti.

Strukturirani sažetak na hrvatskom jeziku dat će kratak teorijski uvod koji opisuje načine određivanja parametara plazme, opis eksperimenta, te prikaz i diskusiju dobivenih rezultata.

TEORIJSKI UVOD

Najčešće korištene metode u određivanju parametara plazme temelje se na proučavanju spektralnih linija koji se optički tanke. Ukoliko promatrane linije nisu optički tanke, već su samoapsorbirane, njihovi linijski profili su zasićeni, što se očituje većom širinom linija i drugačijom površinom ispod linija.

U visokotlačnim izbojima sa živom kao glavnim konstituentom izboja, istraživanje rezonantnog širenja odabranih spektralnih linija žive često se koristi za određivanje gustoće neutralnih atoma žive. Rezonantno širenje nastaje kao posljedica sudara atoma koji zrači sa istovrsnim atomima u osnovnom stanju, te utječe na sve spektralne linije koje nastaju između pobuđenih energijskih stanja atoma koji zrači, a čije je gornje ili donje pobuđeno stanje povezano s početnim, uglavnom osnovnim stanjem atoma smetača (Slika 7)

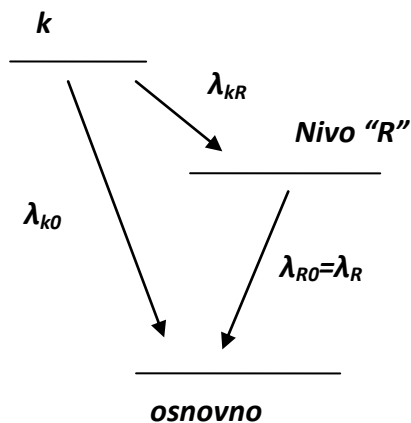

Slika 7 Atomski prijelazi pod utjecajem rezonantnog širenja

Formula za poluširinu na polovici maksimuma (HWHM) izvedena u Griemu je:

$$\Delta\omega = 6,14 \cdot 10^{-14} \cdot \left(\frac{g_1}{g_R}\right)^{1/2} \lambda^2 \lambda_R f_R N, \quad (S-1)$$

gdje je N gustoća neutralnih čestica u osnovnom stanju, g_1 je statistička težina osnovnog stanja, g_R i f_R su statistička težina i jakost oscilatora rezonantnog prijelaza s nivoa „R“.

Metode za određivanje temperature plazme mogu se podijeliti na u dvije grupe, ovisno o tome koriste li se apsolutni ili relativni intenziteti spektralnih linija. U ovom radu korišteni su apsolutni intenziteti optički tanke živine linije na 577 nm, a temperatura je određena iz relacije koja povezuje apsolutne emisijske koeficijente i temperaturu:

$$\varepsilon_L = \frac{h\nu A_{ji} g_j N}{4\pi} \cdot e^{-\frac{E_j}{kT}}, \quad (S-2)$$

gdje je E_j energija gornjeg stanja, A_{ji} vjerojatnost prijelaza, N gustoća atoma u osnovnom stanju i ε_L emisijski koeficijent.

Također je iz poznatih emisijskih koeficijenta za različite lateralne stupce plazme određena i radijalna raspodjela temperature.

EKSPERIMENT

Istraživani metal halogeni Hg-In izboj („Powerstar HQI-T 400 BLUE“ , Osrama). Napaja se izmjeničnim naponom, uz struju između 3,5 i 3,6 A, ima kvarcni cilindrični osnosimetrični žižak čija je duljina luka oko 5 cm, a unutarnji promjer kvarcnog žiška 18 mm. Slika 8 prikazuje vidljivi dio spektra indija i žive.

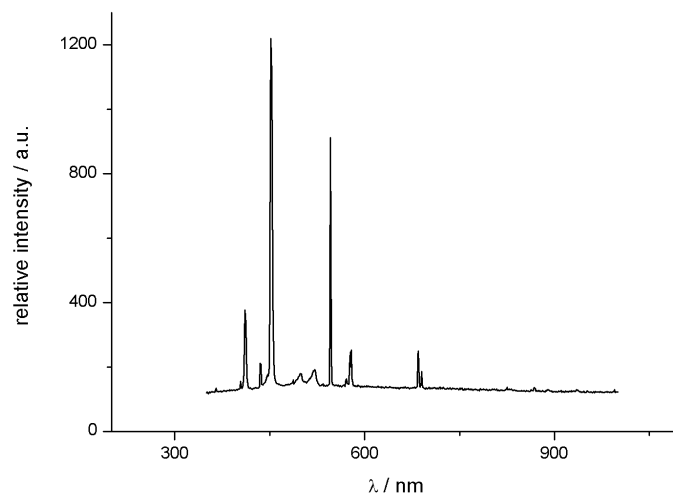

Slika 8 Spektar žive i indija snimljen solid state spektrometrom

Schema eksperimentalnog postava korištenog u istraživanju prikazana je na slici 9. Korištena su dva osnovna eksperimentalna postava: jedan za vremenski usrednjena mjerenja i drugi za vremenski razlučiva mjerenja. Eksperimentalni postav uključuje metal-halogeni izvor svjetlosti, niskotlačni izvor svjetlosti (radiometrijski standard zračenja), leće, sferno zrcalo, zrcalo, monokromator i fotomultiplikator, strujno-naponsko pojačalo, analogno-digitalni pretvarač i računalo. Eksperimentalni postav za vremenski razlučiva mjerenja sadrži još i Boxcar Averager, osciloskop i fotodiodu.

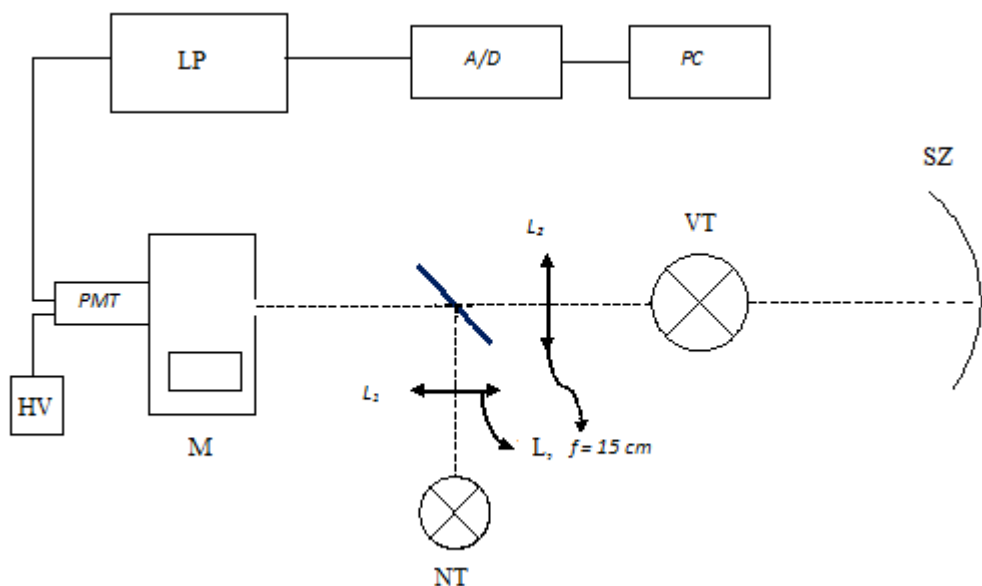

Slika 9 Eksperimentalni postav za vremenski usrednjena mjerenja. VT – visokotlačni izvor, NT – niskotlačni izvor, SZ – sferno zrcalo, L – leća, M – monokromator, PMT – fotomultiplikator, HV – izvor napajanja za fotomultiplikator, LP – strujno-naponsko pojačalo, A/D - analognu-digitalni pretvarač i PC - računalo.

Optički sustav povećanja 3:1 preslikava stupac plazme na ulaznu pukotinu monokromatora. Bočnim pomicanjem leće (u odnosu na optičku os) preslikavaju se različiti presjeci stupca plazme na ulaznu pukotinu. Na ovaj način moguće je izmjeriti prostornu raspodjelu zračenja plazme u smjeru okomitom na optičku os.

Sferno zrcalo, koje se nalazi s druge strane metal halogenog izboja, koristi se za mjerenja utjecaja samoapsorpcije na oblik spektralnih linija. Konkavno sferno zrcalo nalazi se na udaljenosti od izboja koja je jednaka polumjeru zakrivljenosti zrcala, tako da se izboj preslikava u sebe samog. Tako se stupac plazme dva puta preslikava na ulaznu pukotinu monokromatora.

Korištena su dva monokromatora: SPM2 (Spiegel Plangitter Monochromator model 2 s fotomultiplikatorom EMI 9534B) za linije u vidljivom dijelu spektra i ACTON (Acton Res. Inc., model SP2750 s fotomultiplikatorom Hamamatsu R406) za infracrveni dio spektra.

Signal s fotomultiplikatora odlazi u strujno – naponsko pojačalo. Pojačani napon vodi se u analognu – digitalni pretvarač koji analogne impulse pretvara u digitalne, pogodne za daljnju analizu u računalu.

Da bi provjerili kako se parametri plazme mijenjaju s fazom izmjenične struje, korišten je eksperimentalni postav za vremenski razlučiva mjerenja. Izlazni signal s fotomultiplikatora mjeri se pomoću Boxcar averagera. Boxcar averager iz dolaznih električnih signala prikuplja samo one koji su uvijek u istoj fazi izmjenične struje napajanja, tako da prikuplja signale koji stignu na njegov ulaz samo za vrijeme trajanja njegovog otvora. Relativni položaj vremenskog otvora boxcara u odnosu na okidač i vrijeme trajanja otvora mogu se izabrati. Referentni signal koji se koristi za okidanje boxcara dolazi od fotodiode. Odgovarajućim izborom vremena trajanja otvora boxcara i vremena okidanja istražuje se vremensko ponašanje spektra zračenja plazme.

REZULTATI I DISKUSIJA

Spektralne linije zračene metal-halogenim izbojem u parama žive prvo su mjerene vremenski usrednjenom emisijskom spektroskopijom. Svaka točka u profilu spektralne linije dobivene na ovaj način predstavlja srednju vrijednost preko nekoliko desetaka perioda izmjenične struje.

Određivanje elektronske temperature iz mjerenja apsolutnih intenziteta spektralnih linija, odnosno određivanje gustoće neutralnih atoma iz istraživanja širenja spektralnih linija zahtjeva da je plazma u istraživanom području optički tanka, da bi se izbjegao utjecaj samoapsorpcije zračenja. Postupkom udvostručavanja izvora zračenja pomoću sfernog zrcala eksperimentalno je provjerena samoapsorpcija zračenja. Izračunat je faktor korekcije

$$K_{\lambda,corr} = \ln \frac{\left[\frac{R^C - 1}{R\lambda - 1} \right]}{1 - \frac{R\lambda - 1}{R^C - 1}},$$
 te je pokazano da se linije mogu smatrati optički tankima.

Izmjerenim relativnim intenzitetima linije žive na 577 nm pridruženi su njezini apsolutni intenziteti usporedbom s niskotlačnim izvorom žive koji je radiometrijski standard. Da bi mogli usporediti dva izvora zračenja, u ovom slučaju visokotlačni i niskotlačni izboj žive, optika preslikavanja izvora na ulaznu pukotinu monokromatora mora biti tako podešena da se mjeri zračenje iste površine i istog prostornog kuta. To je postignuto korištenjem dvije potpuno jednake leće L_1 i L_2 (Slika 9) Niskotlačni izboj žive smješten je na jednakoj udaljenosti od leće L_1 kao i visokotlačni izboj od leće L_2 . Iz omjera intenziteta linije 577 nm između visokotlačnog i niskotlačnog izboja i uz poznati apsolutni intenzitet linije 577 nm iz niskotlačnog izboja određen apsolutni intenzitet te linije u visokotlačnom izboju.

Na širinu linija osim samih procesa u plazmi utječe i instrumentalna funkcija monokromatora. Instrumentalna funkcija određena je obasjavanjem ulazne pukotine monokromatora zračenjem koje odgovara spektralnoj liniji čija je širina gotovo zanemariva, tako da svojstva monokromatora određuju opaženi oblik linije. Instrumentalni profil mjerene spektralne linije nabolje je opisan Gaussovom funkcijom, čija širina odgovara širini instrumentalne funkcije.

Mjerene spektralne linije su fitane Voigtovim profilom. Voigtov profil je konvolucija Gaussove funkcije koja predstavlja instrumentalnu funkciju monokromatora i Lorenzove funkcije kojom je predstavljano sudarno širenje.

Spektralna raspodjela zračenja plazme izmjerena je za različite lateralne položaje stupca plazme bočnim pomicanjem leće L_2 (Slika 9) pri čemu su na ulaznu pukotinu monokromatora preslikani različiti presjeci stupca plazme u koracima od po 0,375 mm.

Gustoća neutralnih atom žive u osnovnom stanju određena je korištenjem rezonantnog širenja živinih linija na 577 nm ($6^3D_2 - 6^1P_1$) i na 1014 nm ($7^1S_0 - 6^1P_1$). Slike 10 i 11 prikazuju raspodjelu širina linija u ovisnosti o udaljenosti od centra izboja.

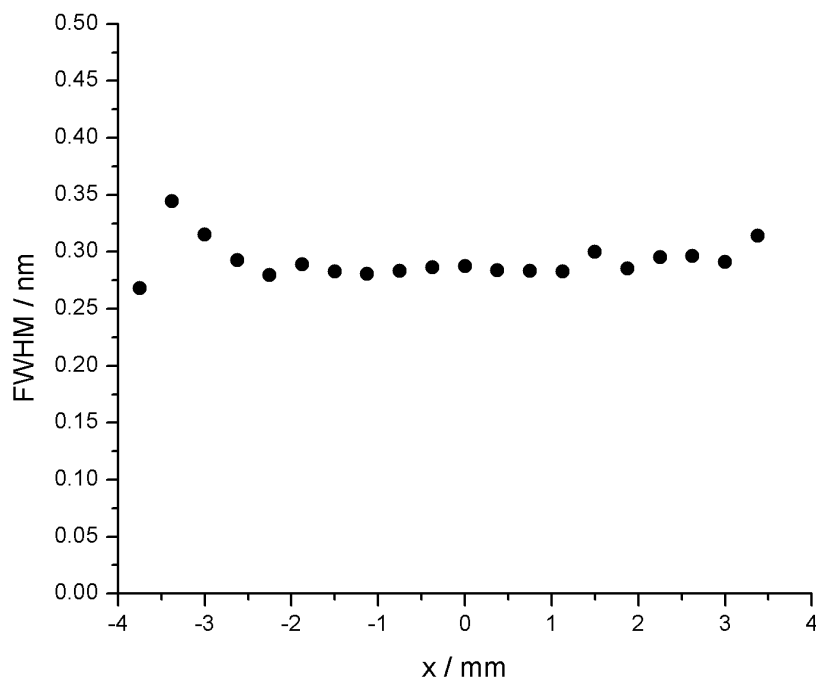

Slika 10 Raspodjela širina linije 577 nm u ovisnosti o udaljenosti od centra izboja

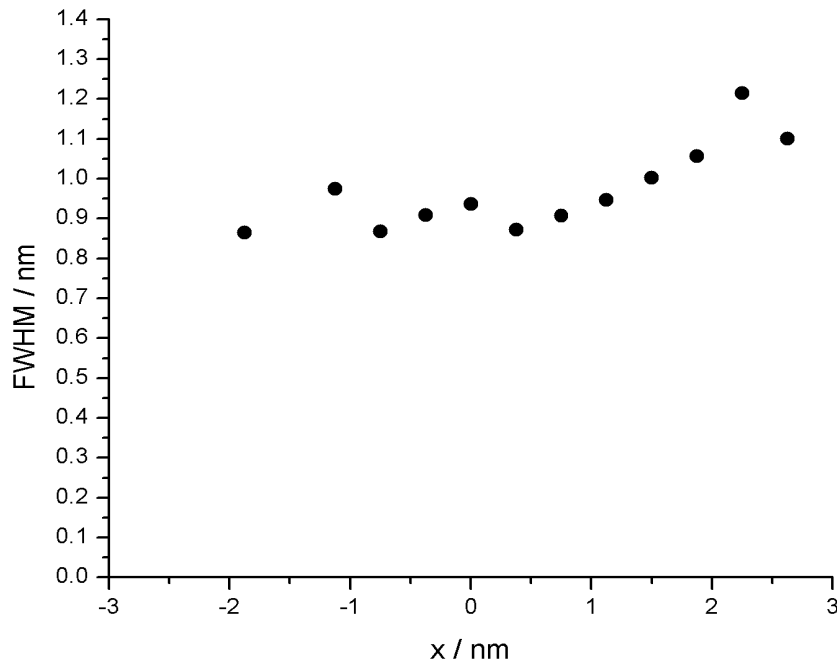

Slika 11 Raspodjela širina linije 1014 nm u ovisnosti o udaljenosti od centra izboja

Gustoća atoma žive u osnovnom stanju izračunata je prema jednadžbi S-1 i iznosi:

$$N = (2 \pm 0,2) \cdot 10^{18} \text{ cm}^{-3}$$

Elektronska temperatura određena je iz apsolutnih intenziteta optički tanke živine linije na 577 nm. Relativni intenziteti izmjereni su u centru izboja i za stupce plazme za različite udaljenosti od centra izboja (Slika 12). Raspodjela intenziteta fitana je Gaussovom funkcijom širine $\Delta x_G = (2.45 \pm 0.02)$ mm. Polumjer izboja je u točki gdje je $I(r_0) = 1/10 I_{max}$ i on ima vrijednost $r_0 = 2.72$ mm.

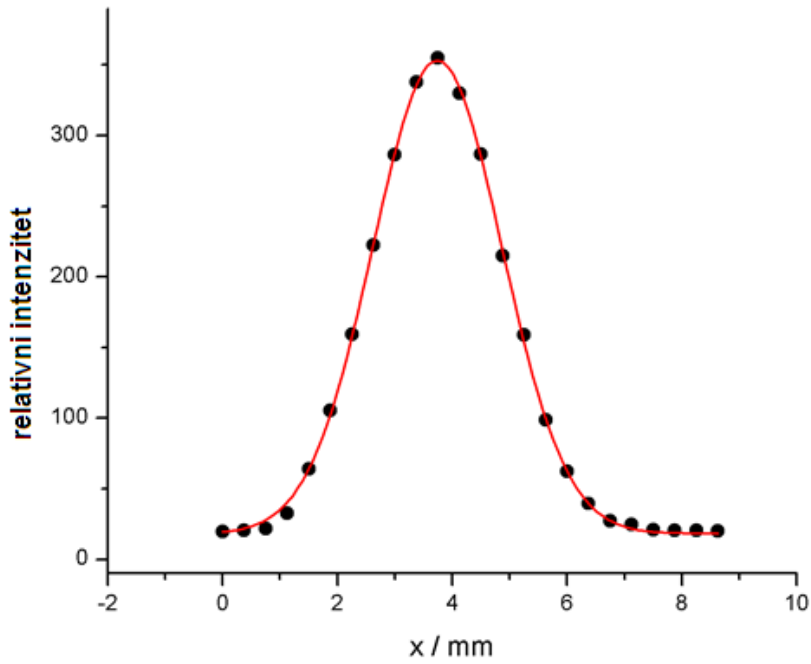

Slika 12 Relativni intenziteti za različite udaljenosti od centra izboja. Centar izboja je u $x_c = (3.739 \pm 0.007)$ mm.

Koristeći 10 ekvidistantnih točaka koje predstavljaju relativne intenzitete unutar radijusa r_0 i izračunati apsolutni intenzitet za živinu liniju na 577 nm u visokotlačnom izboju, izračunati su apsolutni intenziteti kao funkcija udaljenosti od centra izboja. Iz apsolutnih intenziteta uz korištenje Abelove inverzije dobiveni su emisijski koeficijenti prikazani na slici 13.

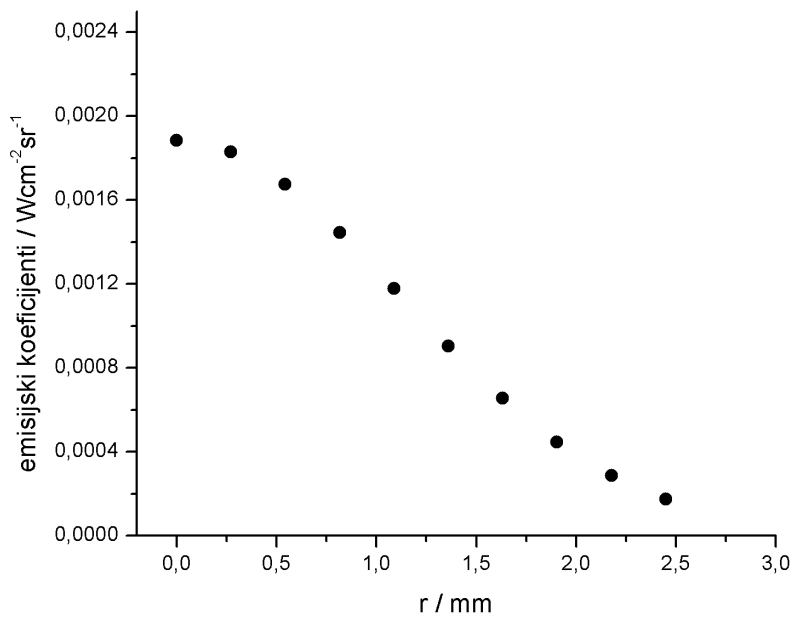

Slika 13 Emisijski koeficijenti

Koristeći jednadžbu S-2 dobivena je raspodjela temperature u ovisnosti o udaljenosti od centra izboja (Slika 14)

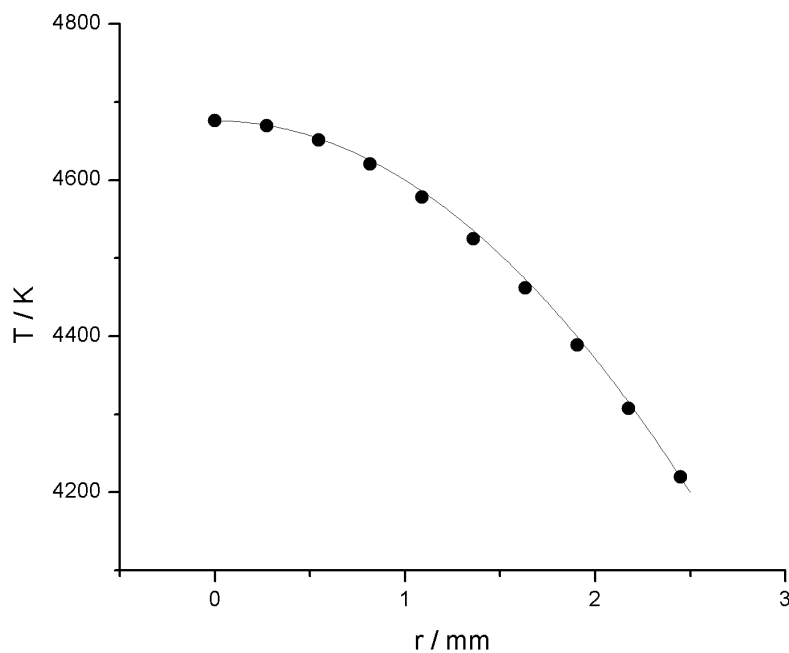

Slika 14 Raspodjela temperature u ovisnosti o udaljenosti od centra izboja

Temperaturni profil na slici 14 najbolje se može opisati sljedećom funkcijom:

$$T(r) = T_C - (T_C - T_0) \frac{r^2}{r_0^2}, \quad (S-3)$$

gdje je T_0 temperatura na rubu izboja na udaljenosti r_0 od centra izboja i iznosi 4220 K, T_C je temperatura u centru izboja i iznosi 4676 K.

Relativna pogreška u određivanju temperature procijenjena je na 15%, a na nju utječu pogreška u određivanju mjerenih relativnih intenziteta, pogreška pri određivanju faktora korekcije za samoapsorpciju, pogreška pri određivanju apsolutnih intenziteta tijekom uspoređivanja visokotlačnog i niskotlačnog izboja i pogreška u određivanju gustoće atoma žive u osnovnom stanju.

Uz poznatu elektronsku temperaturu i gustoću neutralnih atoma žive u osnovnom stanju, može se odrediti tlak živinih para pod pretpostavkom da se živine pare u izboju mogu smatrati jednoatomnim idealnim plinom:

$$p_{Hg} = N_{Hg} k_B T_e.$$

Tlak živinih para iznosi $(1,3 \pm 0,2) \cdot 10^5 \text{ Pa} = (1,3 \pm 0,2) \text{ atm}$.

Korištenjem Boxcar averagera provedena i su vremenski razlučiva mjerenja.

Mjereno je zračenje iz centra izboja, a mijenjana je faza struje. Na taj način promatrano je kako je intenzitet i širina spektralnih linija mijenjaju sa promjenom faze. Rezultati su prikazani na slici 15.

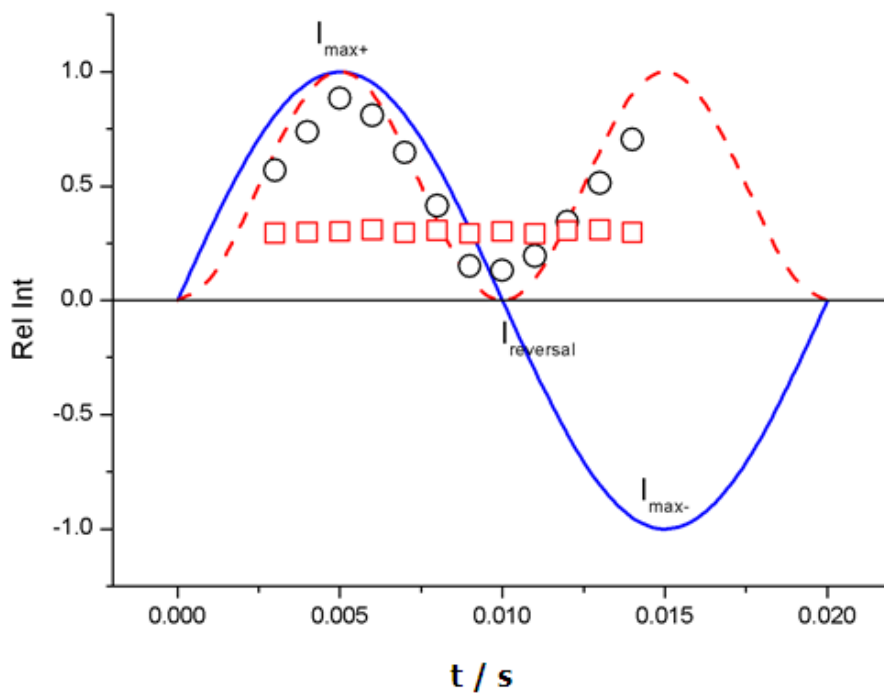

Slika 15 Normalizirani intenziteti i širine linija za različite faze struje. Plava sinusoida predstavlja struju. Crvena isprekidana crta predstavlja apsolutnu vrijednost funkcije sinus. Kružići predstavljaju relativne intenzitete, a kvadratići širinu spektralne linije

Također su promatrani relativni intenziteti i širine linija za različite udaljenosti od centra izboja. Mjerenja su napravljena za minimum i maksimum struje, kao i za tri faze između minimuma i maksimuma.

Kao što se može vidjeti na slikama 16 i 17 relativni intenziteti i širine linija mijenjaju se ovisno o fazi struje. Za maksimalnu struju i relativni intenzitet je maksimalan.

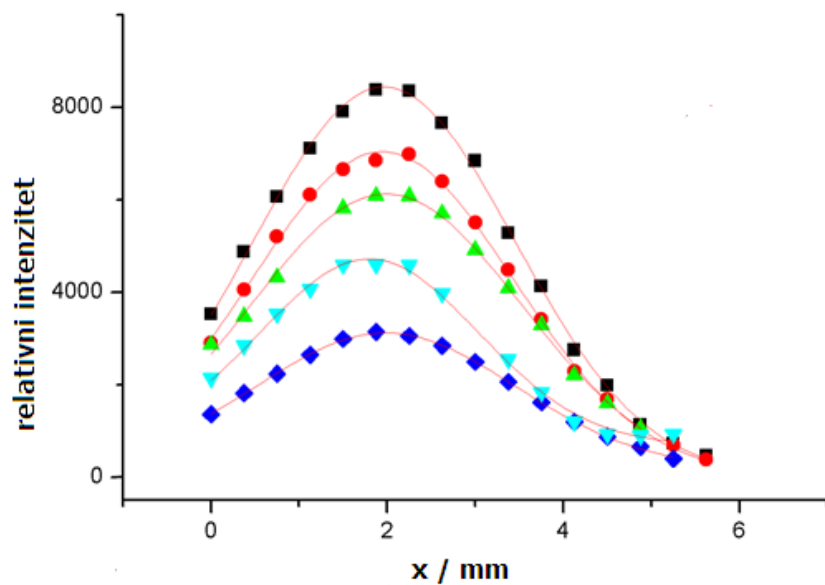

Slika 16 Relativni intenziteti linije 1014 nm. Centar izboja je u $x = 2$ mm.

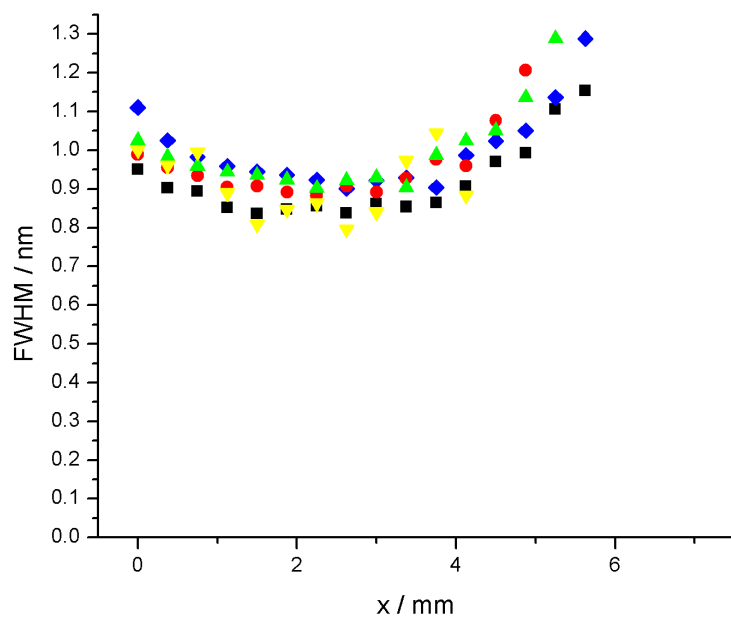

Slika 17 Širine linije 1014 nm u ovisnosti o udaljenosti od centra izboja. Centar izboja je u $x = 2$ mm

Vremenski usrednjenom spektroskopijom određeni su parametri plazme u izboju žive i indija. Elektronska temperatura u centru izboja iznosi $T = (4676 \pm 701)$ K i $T = (3490 \pm 524)$ K na rubu izboja. Gustoća atoma žive u osnovnom stanju je $N = (2 \pm 0.2) \cdot 10^{18}$ dok tlak živinih para iznosi $p = (1,3 \pm 0,2) \cdot 10^5$ Pa. Temperature su uspoređene s temperaturama određenim u radu Dakina, Stromberga i Karabourniotisa. Dakin je u središtu izboja odredio temperaturu od 5000 K i taj rezultat je usporediv a našim rezultatima. Karabourniotis je proučavao izboj sa čistom živom, čija temperatura je viša (iznosi 8300 K) nego temperatura koja je dobivena iz naših mjerenja. To se može objasniti prisutnošću indija, koji ima znatno niži ionizacijski potencijal, u našem izboju. Gustoća atoma žive u osnovnom stanju uspoređena je s gustoćom u radu Lawlera. Uz slične parametre plazme izračunate gustoće međusobno su usporedive.

CURRICULUM VITAE

Personal Data:

Lana Ivanjek

Date of Birth: April 23, 1983

Place of Birth: Zagreb, Croatia

Nationality: Croatian

E-mail address: лана@phy.hr

Working experience:

2006. - present: University of Zagreb, Faculty of science, Department of Physics:
Scientific novice / teaching assistant

Teaching experience:

Undergraduate courses on Faculty of Science, Department of Physics:

Education Seminary in Physics Education (2009 – Present)

Introductory Physics 1 & 2 for future Physicists (2009/10)

Introductory Physics 1 - 4 for future Physics Teachers (2008 - 2009)

Laboratory on Experiments in Physics Education (2006 – 2008)

Education:

2006 – Present: University of Zagreb, Faculty of science, Graduate study of Physics,

Field: Atomic and molecular Physics and Astrophysics

2001 – 2006: University of Zagreb, Faculty of science, Department of Physics

Field: physics teacher

1997 – 2001: *Secondary school in Zagreb: V. Gymnasium*

Awards:

Compliment of Faculty of Science council for extraordinary success during undergraduate study (2005)

Organization competences:

Member of organization committee of:

Eight Croatian Physics Education Conference - 2007

Summer school for young physicists – 2008

Ninth Croatian Physics Education Conference – 2009

Tenth Croatian Physics Education Conference - 2011

Member of the national committee for Physics competitions (2007 – present)

Publications:

1. Planinić, Maja; Ivanjek, Lana; Sušac, Ana. The Rasch model based analysis of the Force Concept Inventory, *Physical Review Special Topics - Physics Education Research*. 6 (2009)

2. Planinić, Maja; Milin-Šipuš, Željka; Katić, Helena; Ivanjek, Lana; Sušac, Ana. Comparison of student understanding of line graph slope in physics and mathematics, *International Journal of Science and Mathematics Education – accepted for publication*

3. Ivanjek, L.; Shaffer, P.S.; McDermott, L.C.; Planinic, M.; Veza, D. Identifying student difficulties with atomic spectra, *sent for publication in American Journal of Physics*

4. Planinić, Maja; Ivanjek, Lana; Sušac, Ana; Pećina, Planinka; Krsnik, Rudolf; Planinić, Mirko; Jakopović, Željko; Halusek, Vlado. Large-scale research on Croatian high school students' conceptual understanding in mechanics // *GIREP - EPEC Conference 2007 Selected Contributions, 2008. 295-300 (lecture, international peer-review, published, scientific).*

5. Ivanjek, Lana, McDermott, Lillian C., Shaffer, Peter & Planinić, Maja. Preliminary investigation of student understanding of spectra // *Teaching and learning physics today: Challenges? Benefits? Reims: Universite de Reims Champagne-Ardenne, 2010. 135-135 (lecture, international peer-review, abstract).*

6. Planinić, Maja; Ivanjek, Lana; Sušac, Ana. Measurement in physics education research with the Rasch model // *GIREP – ICPE – MPLT 2010 Conference: Teaching and Learning Physics Today, Book of Abstracts. Reims : Universite de Reims Champagne - Ardenne, 2010. 192-192 (lecture, international peer-review, abstract).*

7. Ivanjek, Lana; Planinić, Maja; Sušac, Ana. Influence of interactive teaching methods on

students' conceptual knowledge in mechanics and electricity and magnetism // *Physics Curriculum Design, Development and Validation, Nicosia, Cyprus, 2008. 139-139. (lecture, international peer-review, abstract, scientific).*

8. Ivanjek, Lana; Planinić, Maja; Sušac, Ana. Influence of interactive teaching methods on students' conceptual knowledge in mechanics and electricity and magnetism // *Ninth Croatian Physics Education Conference proceedings /Zagreb: Croatian Physics Society, 2009. 286-289. (lecture, domestic peer-review, published, scientific).*

9. Ivanjek, Lana; Sušac, Ana. Learning Physics through guided inquiry // *Ninth Croatian Physics Education Conference proceedings /Zagreb: Croatian Physics Society, 2009. 249-251 (lecture, domestic peer-review, published, expert).*

10. Lana Ivanjek. Can we see behind the corner? // *Matematičko fizički list. 233 (2008); 29-29 (journal article).*

11. Ivanjek, Lana. Simple experiments that demonstrate air pressure. // *Matematičko fizički list. 228 (2007); 254-254 (journal article)*