

The origin of the reduction of loss in current-carrying ferromagnets

Sabolek, Stjepan; Babić, Emil; Zadro, Krešo

Source / Izvornik: **Fizika A, 1992, 1, 167 - 173**

Journal article, Published version

Rad u časopisu, Objavljena verzija rada (izdavačev PDF)

Permanent link / Trajna poveznica: <https://um.nsk.hr/um:nbn:hr:217:136471>

Rights / Prava: [In copyright](#)/[Zaštićeno autorskim pravom.](#)

Download date / Datum preuzimanja: **2025-03-23**



Repository / Repozitorij:

[Repository of the Faculty of Science - University of Zagreb](#)



THE ORIGIN OF THE REDUCTION OF LOSS IN CURRENT-CARRYING
FERROMAGNETS

STJEPAN SABOLEK, EMIL BABIĆ and KREŠO ZADRO

Department of Physics, Faculty of Science, PO Box 162, 41000 Zagreb, Croatia

Received 13 October 1992
UDC 538.955

Original scientific paper

A simple model for the explanation of the decrease of coercive field H_c and loss E in magnetic ribbons carrying an electric current has been proposed. For lower currents accurate measurements performed on amorphous $\text{Co}_{70.3}\text{Fe}_{4.7}\text{B}_{10}\text{Si}_{15}$ ribbon confirm the validity of the model. The results for higher currents can also be explained in terms of the same model providing that the influence of the perpendicular field (caused by the current flow) on the actual domain structure is taken into account. Based on the model predictions a new type of soft magnetic material is proposed.

1. Introduction

For some time it has been known that an electric current passing along the magnetic ribbon influences its magnetization^{1,2)}. In particular some decrease in the coercive field H_c has been reported. More recently a drastic reduction of H_c and loss E has been achieved by passing direct current through MetglassR 2714 ribbons³⁾. Since rather low currents used in these experiments ruled out the domain wall (DW) dragg⁴⁾ the phenomenon was ascribed to the effects of the magnetic field H_p caused by the flow of current. Later experiments confirmed this hypothesis⁵⁾ and moreover have shown that the phenomenon does not depend on the actual origin of H_p ⁶⁾. This knowledge has been used recently in order to produce the prototype composite magnetic material with soft magnetic properties exceeding those of the original material⁷⁾.

In what follows we use our model in order to calculate the variation of H_c with

H_p for the hypothetical material consisting of two domains with antiparallel magnetizations. Further we use these results in order to explain the experimental data obtained for amorphous $\text{Co}_{70.3}\text{Fe}_{4.7}\text{B}_{10}\text{Si}_{15}$ ribbon (hereafter CoFeBSi). Finally we explain the difference between the calculated and observed variations occurring at higher values of H_p in terms of the influence of H_p on the actual domain structure of such samples.

2. Experimental procedure

The measurements of the hysteresis loops of amorphous CoFeBSi ribbon have been performed with an induction technique at room temperature⁸⁾. The nonmagnetostrictive alloy has been selected because the domain structure of such ribbons⁹⁾ is suitable for the application of our model and because the process of magnetization of this sample in the absence of the current flow has been known in some detail¹⁰⁾. The triangular driving field H with the amplitude $H_{max} = 25$ A/m and the frequency $f \doteq 5.5$ Hz have been used. The selected parameters enabled us to work with well defined magnetization processes (H_{max}) and to avoid the excessive influence of the eddy current on the hysteresis curves. Direct current J flowing along the ribbon produces magnetic field H_p perpendicular to its length and antiparallel at the opposite surfaces. For a long thin ribbon $H_p \doteq J/2w$ (w is the width of the ribbon) at its surfaces and vanishes at its center. The influence of H_p on the parameters of the hysteresis loops of CoFeBSi ribbon has been studied.

3. Model and calculation

It is well known that the magnetization of the domains I in amorphous ribbons is not quite parallel to their length¹¹⁾. Because of this H_p has a nonvanishing projection on I , $P = H_p \sin \delta$ (δ is the angle between I and the long axis of the ribbon as shown in the inset to Fig. 1) and therefore affects the magnetization of the ribbon. In particular depending on the direction of H_p , P can either enhance or diminish the pressure of the driving field H on the domain wall (DW). The effect of H_p on DW depends on δ and the location of pinning centres (H_p decreases inside the ribbon). Because of this we expect larger effect of H_p when pinning of DW is strongest at the ribbon surfaces (as is the case in nonmagnetostrictive ribbons¹²⁾). In what follows we will calculate the variation of H_c with H_p for the ribbon consisting of two domains with antiparallel magnetizations¹ (Fig. 5 in Ref. 5.).

The magnetization starts when the projection of H onto I , $P_H = H \cos \delta$, reaches the magnitude S which is required to release DW. When pinning of DW at the opposite surfaces has different strength¹²⁾, the corresponding P_H 's will be different too ($P_{Hu} = S_u$ and $P_{Hl} \doteq S_l$ for the upper and lower surface, respectively).

¹Such domains dominate the magnetization of nonmagnetostrictive ribbons⁹⁾.

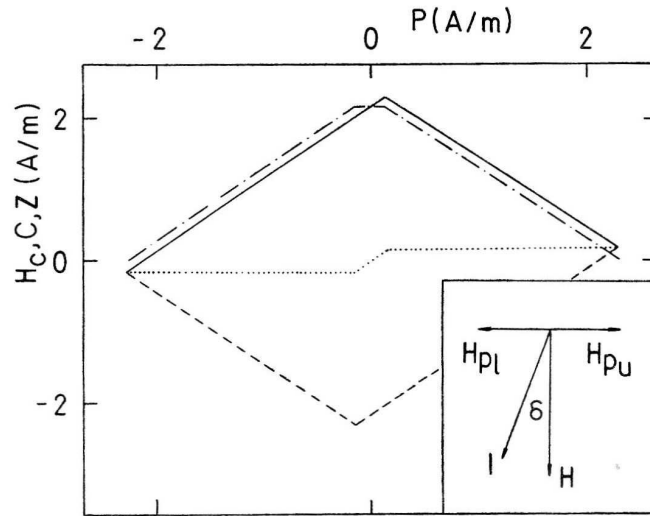

Fig. 1. Calculated coercive field H_c ($-\cdot-\cdot-$), center of the hysteresis loop C ($\cdot\cdot\cdot$) and projections Z of driving field H for “positive” (—) and “negative” ($---$) H (see text) vs. projection P of the field H_p caused by the ribbon current for two domains separated by 180° wall. The inset: vectorial representation of H , H_p (H_{pu} and H_{pl} at upper and lower surface of ribbon, respectively) and domain magnetisation I .

However DW will always be released from the surface with lower S . Therefore in the absence of H_p and assuming¹²⁾ $S_u < S_l$, $H_{co} \doteq S_u$.

When current flows through the ribbon, P_H and P act together on DW. For H changing from $-H_{max}$ to H_{max} (“positive” H) and H_{pu} and H_{pl} specified in the inset to Fig. 1, P_H ’s required in order to release DW at the opposite surfaces of the sample are

$$P_{Hu} \doteq S_u + P, \quad (1)$$

$$P_{Hl} = S_l - P. \quad (2)$$

For H changing in the opposite direction (“negative” H)

$$P_{-Hu} = -S_u + P, \quad (3)$$

$$P_{-Hl} = -S_l - P. \quad (4)$$

The relations for P_H^- ’s corresponding to opposite direction of J (opposite H_p ’s) are obtained by exchanging the signs of P ’s in Eqs. (1)–(4).

Since the magnetization changes whenever the projection of H reaches the lowest value required in order to depin DW in given circumstances (direction of H ,

directions and magnitudes of H_p 's) only parts of relations for P_H 's and P_H^- 's (full lines for "positive" and dashed for "negative" H in Fig. 1) will be relevant for the determination of width (H_c) and position (C) of the hysteresis loop. In particular for $P \leq (S_l - S_u)/2$ follows $P_{Hu} < P_{Hl}$ and $P_{-Hu} < P_{-Hl}$. Because of this, as shown in Fig. 1,

$$H_c \doteq (P_{Hu} - P_{-Hu})/2 = S_u, \quad (5)$$

i.e. H_c remains fixed at H_{c0} whereas

$$C = (P_{Hu} + P_{-Hu})/2 \doteq P \quad (6)$$

shifts with P .

Analogously for $P > (S_l - S_u)/2$,

$$H_c = S_u + (S_l - S_u)/2 - P \quad (7)$$

decreases with P whereas

$$C = (S_l - S_u)/2 \quad (8)$$

remains constant (Fig. 1). The variations of H_c and C for the other direction of J (opposite signs of P 's) are obtained in the same way from the expressions for P_H^- 's. Variations of H_c and C with P are symmetrical in respect to $P = 0$ (Fig. 1) and ignoring the eddy current loss, H_c is expected to vanish at $P = (S_l + S_u)/2$. We note that in Fig. 1 we used the values of S_u and S_l deduced from the experimental results for CoFeBSi ribbon and assumed that they are independent of H_p .

4. Results and discussion

The variations of H_c and C with H_p for nonmagnetostrictive CoFeBSi ribbon are shown in Figs. 2 and 3. Since for the selected H_{max} strong pinning centres located at the surfaces of the ribbon¹²⁾ dominate the magnetization processes¹⁰⁾, $H_p = J/2w$ has been used. In nonmagnetostrictive ribbons wide domains separated by 180° DW dominate the magnetization⁹⁾. Therefore if the magnetizations of such domains can be represented with an average δ one would expect the variations of H_c and C similar to those shown in Fig. 1. Figures 2 and 3 show that this is so for $H_p \leq 5$ A/m. Moreover from the variation of C for $H_p \leq 1$ A/m and H_c for 1 A/m $\leq H_p \leq 5$ A/m we deduce the same value of $\delta = (6 \pm 1)^\circ$ and obtain reasonable $S_l - S_u \simeq 0.3$ A/m.

Whereas H_c continues to decrease beyond $H_p = 5$ A/m (Fig. 2), C shows another strong increase (Fig. 3) which cannot be explained in terms of our simplified model of the domain structure (unique δ). Indeed some domains with magnetizations forming large angles with the ribbon long axis have been observed at the surfaces of nonmagnetostrictive ribbons¹³⁾. These domains are apparently of minor

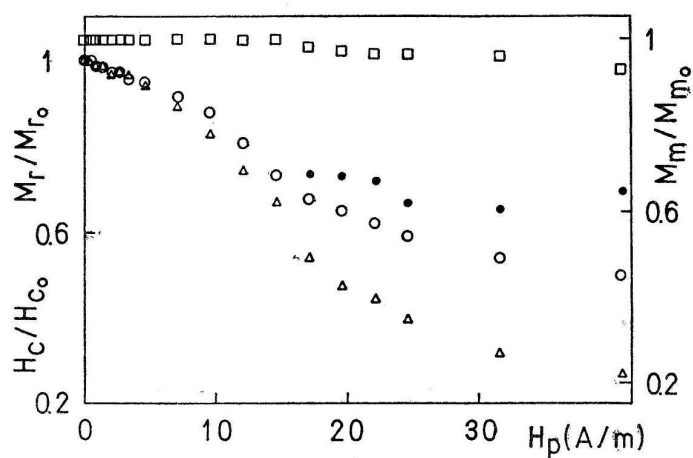

Fig. 2. Normalized maximum magnetization M_m (\square), remanent magnetization M_r (Δ) and coercive field H_c with (\bullet) and without (\circ) correction for the change of M_m vs. magnetic field H_p caused by the ribbon current for CoFeBSi alloy.

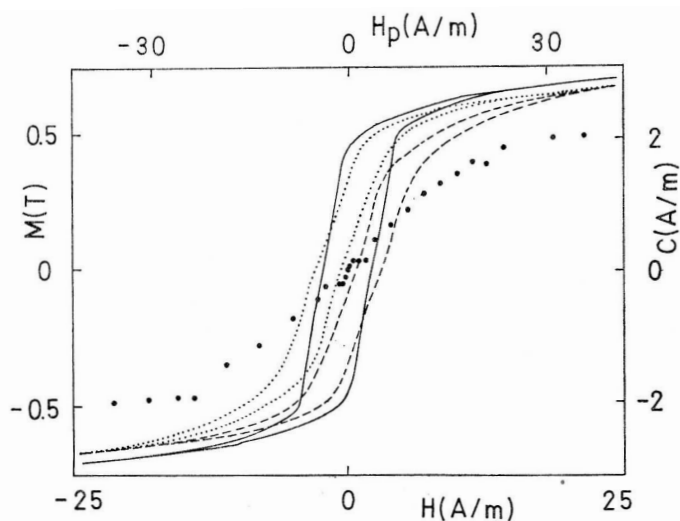

Fig. 3. Hysteresis loops of CoFeBSi ribbon at 5.5 Hz for $H_p \doteq 0$ (—), 30 (\cdots) and -30 A/m ($-\ -$). Shift of the center of the loop C (\bullet) with H_p .

importance⁹⁾ for H_c in the absence of H_p . However, since they become more stable on increasing H_p they may become efficient DW pinning centres¹⁴⁾ at elevated H_p . Since different domain pattern were observed at the opposite surfaces of the ribbons it seems clear that the stabilisation of the unfavourably oriented domains would lead to a change in the pinning inhomogeneity $S_l - S_u$ and hence to the shift of C . This process should end when sufficiently stable domain patterns form at both

surfaces of the sample.

The observed variation of C (Fig. 3) seems to confirm the above considerations and shows that at sufficiently large H_p , $S_l - S_u$ is not constant as assumed in calculating C and H_c shown in Fig. 1. However any increase in $S_l S_u$ or S_u should slow down the decrease of H_c with H_p (Eq. (7)) which is consistent with the small hump of H_c observed around $H_p = 10$ A/m but is inconsistent with its strong decrease centered around $H_p \simeq 15$ A/m (Fig. 2). We note however that simultaneously the maximum magnetization M_m starts to decrease with H_p (Fig. 2). (This confirms our claim that at elevated H_p unfavourably oriented domains become efficient DW pinning centres.) At the same time H_c at a given frequency depends on M_m , the exact relation depending on dominant magnetization processes¹⁰). In particular for the employed range of M_m and f , $H_c \sim M_m^3$ has been established¹⁰). Subtracting this contribution of H_c from the experimental data we find that practically complete decrease of H_c above $H_p = 14$ A/m is due to the decrease of M_m (Fig. 2). Moreover the corrected results indicate that at elevated H_p , H_c would increase rather than decrease with H_p providing that M_m is kept constant.

The variation of the remanent magnetization M_r with H_p is qualitatively the same as that of H_c (Fig. 2). However the decrease of M_r with H_p is always faster than that of H_c because both the narrowing (H_c) and slanting of the hysteresis loop (Fig. 3) decrease M_r . Since slanting occurs^{3,6}) because of variation in δ for different domains as well as due to the increase of the DW pinning strengths with H_p , the explanation of M_r always requires the exact knowledge of the domain structure.

5. Conclusion

The results presented above confirm that the reduction of H_c in magnetic ribbons carrying an electric current is associated with the perpendicular field H_p caused by the current flow. Calculation performed for a simplified model of the domain structure of nonmagnetostrictive ribbons describes well the experimental results for CoFeBSi ribbon at lower H_p . A more detailed domain structure is required in order to explain the behaviour observed at higher H_p . In spite of that the model is helpful because it can help to single out the details of the domain structure which limit the reduction of H_c and loss E . This may help the search for more suitable materials and/or the processing techniques which produce a more favourable domain structure.

At the same time the model shows that large reduction of H_c and E can only be obtained if the projection of the additional field on I is large. Because of this larger effects would be obtained by the use of longitudinal magnetic field H_l instead of H_p . Since H_l cannot stabilize the domains with unfavourable magnetizations, Eqs. (5)–(8) with $P = H_l \cos \delta$ should apply over entire range of H_p . The preparation of composite materials with H_l replacing H_p is in progress.

Acknowledgements

The support of NIST (formerly NBS) via funds made available through scientific cooperaton between Croatia and U. S. A. is acknowledged.

References

- 1) C. Aroca, E. Lopez and P. S. Sanchez, *J. Magn. Magn. Mater.* **23** (1981) 193;
- 2) R. N. G. Dalpadado, *IEEE Trans. Magn. MAG-17* (1981) 3163;
- 3) J. Horvat and E. Babić, *J. Magn. Magn. Mater.* **92** (1992) L25;
- 4) L. Berger, *J. Appl. Phys.* **50** (1979) 2137;
- 5) J. Horvat, E. Babić, . Marohnić and H. H. Liebermann, *Phil. Mag. B* **63** (1991) 1235;
- 6) J. Horvat, E. Babić and G. J. Morgan, *J. Magn. Magn. Mater.* **104–107** (1992) 359;
- 7) S. Sabolek, J. Horvat, E. Babić and K. Zadro, *J. Magn. Magn. Mater.* **110** (1992) L25;
- 8) J. Horvat, Ž. Marohnić and E. Babić, *J. Magn. Magn. Mater.* **82** (1985) 5;
- 9) C. Aroca, P. S. Sanchez and E. Lopez, *IEEE Trans. Magn. MAG-17* (1981) 1462 and references therein;
- 10) J. Horvat, E. Babić, Ž. Marohnić and H. H. Liebermann, *J. Magn. Magn. Mater.* **87** (1990) 339;
- 11) H. J. de Wit and M. Brouha, *J. Appl. Phys.* **57** (1985) 3560;
- 12) J. Horvat and E. Babić, *J. Magn. Magn. Mater.* **96** (1991) L13;
- 13) A. Veider, G. Badurek, R. Grossinger and H. Kronmiiller, *J. Magn. Magn. Mater.* **60** (1986) 182;
- 14) K. H. Stewart, *Ferromagnetic Domains*, Cambridge Univ. Press, Cambridge (1954) p. 165.

PORIJEKLO SMANJENJA GUBITAKA U FEROMAGNETU KOJIM TEČE
STRUJA

STJEPAN SABOLEK, EMIL BABIĆ i KREŠO ZADRO

*Fizički odjel, Prirodoslovno-matematički fakultet Sveučilišta u Zagrebu, Bijenička 32,
41000 Zagreb, Hrvatska*

UDK 538.955

Originalni znanstveni rad

Predloženo je objašnjenje sniženja koercitivnog polja H_c i gubitaka E u magnet-skim trakama kojima teče električna struja. Račun proveden za pojednostavljenu domensku strukturu dobro opisuje rezultate mjerenja na slitini $\text{Co}_{70.3}\text{Fe}_{4.7}\text{B}_{10}\text{Si}_{15}$

kod nižih vrijednosti struje. Rezultati mjerenja kod viših struja se također mogu objasniti modelom ako se uzme u obzir domenska struktura i utjecaj magnetskog polja H_p uzrokovanog strujom na tu strukturu. Na temelju modela i rezultata mjerenja predložen je novi tip mekih magnetskih materijala.