

# Analyzing high school students' reasoning about electromagnetic induction

---

Jeličić, Katarina; Planinić, Maja; Planinšič, Gorazd

Source / Izvornik: **Physical Review Physics Education Research, 2017, 13**

Journal article, Published version

Rad u časopisu, Objavljena verzija rada (izdavačev PDF)

<https://doi.org/10.1103/PhysRevPhysEducRes.13.010112>

Permanent link / Trajna poveznica: <https://urn.nsk.hr/urn:nbn:hr:217:839849>

Rights / Prava: [Attribution 4.0 International](#)/[Imenovanje 4.0 međunarodna](#)

Download date / Datum preuzimanja: **2024-08-25**



Repository / Repozitorij:

[Repository of the Faculty of Science - University of Zagreb](#)



## Analyzing high school students' reasoning about electromagnetic induction

Katarina Jelacic,<sup>1,2</sup> Maja Planinic,<sup>1,\*</sup> and Gorazd Planinsic<sup>3</sup>

<sup>1</sup>*Department of Physics, Faculty of Science, University of Zagreb, Bijenicka 32, 10000 Zagreb Croatia*

<sup>2</sup>*XV. gymnasium, Jordanovac 8, 10000 Zagreb, Croatia*

<sup>3</sup>*Department of Physics, Faculty of Mathematics and Physics, University of Ljubljana, Jadranska 19, 1000 Ljubljana, Slovenia*

(Received 29 November 2016; published 27 February 2017)

Electromagnetic induction is an important, yet complex, physics topic that is a part of Croatian high school curriculum. Nine Croatian high school students of different abilities in physics were interviewed using six demonstration experiments from electromagnetism (three of them concerned the topic of electromagnetic induction). Students were asked to observe, describe, and explain the experiments. The analysis of students' explanations indicated the existence of many conceptual and reasoning difficulties with the basic concepts of electromagnetism, and especially with recognizing and explaining the phenomenon of electromagnetic induction. Three student mental models of electromagnetic induction, formed during the interviews, which reoccurred among students, are described and analyzed within the knowledge-in-pieces framework.

DOI: [10.1103/PhysRevPhysEducRes.13.010112](https://doi.org/10.1103/PhysRevPhysEducRes.13.010112)

### I. INTRODUCTION

Electromagnetic induction is a complex physics topic which combines the knowledge of many laws and concepts from electromagnetism. When reasoning about electromagnetic induction, students have to integrate and apply their knowledge about basic concepts, such as magnetic field, magnetic flux, Lorentz's force, electromotive force (emf), electric field, electric current, and electromagnetic force. Prior research in the field of electromagnetism suggests the existence of many student difficulties regarding electromagnetic induction, but also many difficulties with the underlying electromagnetic concepts.

There exists a considerable amount of research on student difficulties with the basic concepts in the domain of electricity and magnetism [1–11], but relatively few studies focus on the difficulties that students face while tackling the topic of electromagnetic induction (EMI) [12–17]. Yet, EMI might be the most difficult topic in the domain of electricity and magnetism at the introductory level, as some studies suggest [2], at least of those covered by the widely used Conceptual Survey in Electricity and Magnetism (CSEM) [1].

Several student difficulties with electromagnetism concepts, concerning both underlying concepts as well as electromagnetic induction, were revealed by the CSEM

[1,2]. Students were often confusing magnetic force with electric force, and had difficulties determining the direction of the magnetic force on an electric charge, applying the concepts of electric and magnetic field, recognizing changing of the magnetic flux, and implementing Faraday's law. Students' success on conceptual surveys in electromagnetism, such as CSEM [1] and BEMA [18], was found generally to be relatively low for traditional curricula, even after instruction [1,2,18,19], indicating that electromagnetism is a difficult domain for them that requires new teaching approaches. For example, Guisasaola *et al.* [20] addressed this problem by developing a teaching sequence at the university level intended to help students develop and apply Ampere's model of the source of magnetic field and improve their understanding of magnetic field and magnetic force.

Regarding student understanding of electromagnetic induction, several studies documented students' poor ability to recognize and explain the phenomenon and the related experiments. In a search of how students form explanatory hypotheses, Park [9] interviewed six college physics education majors prior to their electricity and magnetism course, and found that students did not recognize the phenomenon of electromagnetic induction in the experiment with a magnet falling inside an aluminum pipe. All six of them expected the same falling time in plastic and aluminum pipes. Loftus [13] investigated secondary school students' difficulties with an understanding of electromagnetic induction. Students had to explain three experiments (closed ring levitating and open ring not levitating over an electromagnet, lighting of a lamp when moving a solenoid over an electromagnet, and heating up of a cooking pot on an induction cooker). The study showed that students had problems with the interpretation of

\*Corresponding author.  
maja@phy.hr

Published by the American Physical Society under the terms of the [Creative Commons Attribution 4.0 International license](https://creativecommons.org/licenses/by/4.0/). Further distribution of this work must maintain attribution to the author(s) and the published article's title, journal citation, and DOI.

experiments and only a few students succeeded in interpreting each experiment correctly. The incorrect reasoning usually included an agent sending and an object receiving something (e.g., force, charge, light) to explain the observations. Some students expected that the agent and the object needed to be in physical contact for the phenomenon to occur.

The cause of the induced emf, the difference between the induced emf and the induced current, and the ways of determining the direction of the induced current, seem generally not to be clear to students. The study of Bagno and Eylon [8] found that only 10% of students mentioned magnetic field variation as a cause of the induced emf and that students had difficulties applying Lenz's law correctly. Students often seemed to misinterpret the phrase "opposes the change" as "being in the opposite direction," when determining the direction of the induced current or induced magnetic field. Guisasola *et al.* [12] found that more than 20% of the first-year university students explained induced current or emf as being due to the presence of the (unchanging) magnetic field in that area or space. Students seemed to think that the field lines crossing the loop were the cause of the induced emf. Thong and Gunstone report [16] that most investigated students (undergraduate second-year students, who studied physics as a main subject) were unaware of the difference between Coulombic and induced electric field and attempted to describe the induced field with electrostatic potential. Students were found also to have difficulties recognizing the induced emf when there was no induced current [13].

Magnetic flux seems to be a difficult concept that students tend to confuse with the magnetic field. This tendency of first-year university students and their failure to notice the change of the magnetic flux as a cause of electromagnetic induction was documented in some studies [3,16]. Saareleinen, Laaksonen, and Hirvonen [3] found many student difficulties with the concepts of electric and magnetic field and suggested that students' poor understanding of electric and magnetic fields as vector fields may explain students' difficulties in shifting from the Coulombian conceptual profile (relying primarily on the concept of force) to a Maxwellian one (using primarily the field concept). These difficulties will also be reflected in students' poor understanding of the concept of magnetic flux, which in addition to difficulties with the concept of field, involves difficulties with understanding of field lines [4,5] as well as requiring assigning a vector to the surface [3]. Because of the difficulties with the concept of magnetic flux, as well as the rate of change concept, students often use Faraday's law without sufficient understanding [12,16].

At the more advanced level, some studies demonstrated university students' problems in recognizing the correct integration path for implementation of Faraday's law, especially in problems concerning calculations of motional

emf [14,15], and their inability to understand the equivalence of the Lorentz's force and the field model explanations of the electromagnetic induction phenomena [15].

Based on the results of the existing studies, Zuza *et al.* [17] presented an overview of student difficulties regarding EMI, which we discuss here in a more condensed form, with the addition of difficulty regarding Lenz's law [8]. The main identified student difficulties seem to be the following:

- (i) difficulty recognizing EMI in phenomena taught in curriculum;
- (ii) difficulty recognizing EMI when there is no induced current;
- (iii) explaining EMI as being caused by the magnetic field;
- (iv) poorly understanding the concept of the magnetic flux and identifying magnetic flux with the magnetic field;
- (v) applying Faraday's law without proper understanding;
- (vi) difficulty understanding and applying Lenz's law;
- (vii) difficulty understanding the equivalence of the explanation of induction phenomena based on a field model (Faraday's law) and on Lorentz's force;
- (viii) confusing circuit area with the integration area in Faraday's law.

The same study [17] presented a teaching sequence for the first-year university students, which helped many students (about 60%) to achieve a more satisfactory understanding of the electromagnetic induction. However, that sequence is not applicable for teaching high school students, since they do not use calculus. Yet, they may exhibit all the difficulties listed above except the second part of the last one, which is related to integration.

Another layer of student difficulties, documented in previous research, may be of an epistemological nature. Bagno and Eylon investigated the structure of final-year secondary school students' knowledge of electromagnetism [8], and found that students lack a hierarchy of ideas in electromagnetism and generally do not recognize the central ideas. Their results suggest that students' knowledge structure lacks organization, resulting in difficulties when retrieving information, and that students tend to memorize mathematical relationships without developing the necessary conceptual understanding. Lack of organization of knowledge and lack of students' need for its coherence [21] may be additional sources of difficulties when students reason about electromagnetic phenomena.

Obviously, EMI requires multilevel reasoning, which is complex and difficult for students of all levels, especially high school students. But the above list of difficulties suggests that many of them are conceptual in nature and can be related to students' wrong or nonexistent conceptual mental models of EMI. Since these models start to form in high school, we wanted to investigate their early formation,

which could potentially be of interest also for the understanding of the formation of mental models of EMI in university students. We hope that this research will ultimately lead towards a high school teaching sequence for EMI that could help teachers to teach electromagnetic induction through an active-learning process, since this topic is an important part of the physics high school syllabus in many countries, Croatia and Slovenia included. High school physics teaching in Croatia, where the research was conducted, is still mostly lecture based and centered on standard problem solving with not enough emphasis on conceptual understanding, although efforts are underway to change that. Such an approach usually misses student difficulties that are prevalent in many domains of physics.

The goal of this research is to investigate high school students' mental models and reasoning difficulties of electromagnetic induction, and to answer the following research questions:

- (1) What are the main high school student difficulties in reasoning about electromagnetic induction?
- (2) What mental models of electromagnetic induction do students hold, and are they consistently used?

## II. THEORETICAL BACKGROUND

Electromagnetic concepts and phenomena are, unlike those in mechanics, generally not a part of students' everyday language and experience, and students are therefore less likely to have strong preformed concepts in electromagnetism than they are in mechanics [22]. This would be especially noticeable in high school students, since the domain of electromagnetism is not something that they would have much contact with before instruction in high school, except very briefly in elementary school. Most physics education research studies on student understanding of electromagnetism concepts involve college or university students and only seldom high school students. Yet, in high school (where possible) students could form a conceptual basis of physics, including some mental models of physics phenomena which can later be further expanded and refined.

Mental models are formed in interaction with the environment, with other people, and with artifacts of technology [23] as internal representations of the world. In physics education, students' mental models are important because of their predictive and explanatory power for understanding physics phenomena. According to Norman [23], when considering mental models, we need to consider four different things: the target system, the conceptual model of that target system, the user's mental model of the target system, and the researcher's conceptualization of that mental model. The system that the person is learning about or using is the target system (in our study the phenomenon of electromagnetic induction). A conceptual model, the one underlying Faraday's law, was invented in physics to provide an appropriate representation of that phenomenon.

The model relies on the idea (concept) of the rate of change of magnetic flux through some surface or alternatively on the concept of Lorentz's force. Through the interaction with the target system (e.g., performing, observing, and explaining experiments demonstrating electromagnetic induction), students form mental models of this phenomenon. For each student, the model will be modified until it reaches a functional state, which means that it can serve to predict and explain. However, students' mental models need not be technically accurate, and it is often demonstrated in physics education research that they are not, but they need to be functional for the student. Obviously, when scientists study students' mental models, they are making a model of a model, which constitutes the fourth element, researcher's conceptualization of a student's model. Among the most important characteristics of mental models [23] are their incompleteness, instability, lack of firm boundaries, and parsimony, which reflects the human tendency to avoid mental complexity and strive for simplified reasoning.

It is important to pose the question about how mental models actually form. When confronted with a qualitative physics problem, students often provide explanations that are incorrect from the physicist's point of view. These explanations are sometimes interpreted as a sign of students' existing alternative conceptions in one framework (knowledge as theory [24,25]), but they can also be viewed in another theoretical framework (knowledge in pieces [26,27]), as a result of on-the-spot, context-dependent activation of cognitive resources. Since we presume that high school students are not likely to possess firm alternative ideas related to electromagnetism concepts, which are abstract and far from their everyday experiences, we consider the second framework (knowledge in pieces) more suitable for analysis of student explanations in this domain. In this framework, small cognitive elements influence students' development of knowledge structures. DiSessa [26] refers to them as phenomenological primitives or *p*-prims, while Hammer *et al.* speak more generally of cognitive resources [27]. Hammer [28] points out that stable and robust cognitive structure, such as firm misconceptions, do not often occur in students, but rather smaller cognitive structures play more vital roles when students think about a physics problem. Explaining some phenomena relies on activation of *p*-prims. The activated *p*-prims sometimes produce correct explanations, but in some situations they might be activated inappropriately and produce incorrect explanations. The activation of cognitive elements, such as *p*-prims, is context dependent and the elements are in themselves neither correct nor incorrect, and can be perceived as potentially productive resources, depending on the appropriateness of their use. There are many *p*-prims which can be activated. Some of the most important or common ones are [26] "force as a mover" (a directed impetus acts in a burst on an object, which causes the motion of the object in the same direction), "continuous



force” (steady effort causes steady motion), “Ohm’s  $p$ -prim” (increased effort leads to more result, increased resistance leads to less result), “dying away” (all motion gradually dies away), “equilibrium” (a system with multiple influences has a natural domain of stability), “dynamic balance” (a pair of forces or dynamic influences are in conflict and happen to balance each other), “overcoming” (one force or influence overpowers another), “canceling” (an influence may be undone by an opposite influence), “guiding” (a determined path directly causes an object to move along it), “generalized springiness” (disruptive influence on equilibrium creates a displacement from equilibrium) and “equilibration” (a return to equilibrium is the natural result of removing a disequilibrating influence).

Hammer [28] further categorizes cognitive resources as conceptual and epistemological; the former are activated by students when discussing or thinking about some physics problem and latter refer to students’ beliefs about knowledge and learning. Teachers are mostly accustomed to tackling students’ wrong concepts, but are often unaware that students’ epistemologies may play an important role in their progress. Hammer [21] concludes that “...*some students’ knowledge may remain fragmented, because, in part, they do not expect it to be coherent...*” The importance of epistemological resources is extensively discussed and studied in works by Hammer and Elby [29–33]. And, as some other studies suggest, it is important not only to study the content of student knowledge, but also its structure and organization [8].

### III. DATA COLLECTION AND ANALYSIS

We interviewed nine high school students from three different schools in Zagreb, Croatia. The interviewed students (age 16–17 years) were in their third year of a four-year high school program and were conveniently sampled. Convenience sampling is a nonprobability sampling and consists of choosing subjects on the basis of their convenient accessibility [34]. The participants were chosen through the interviewer’s (K. J.) teacher network. The schools from which these nine students were chosen are average urban schools that follow the same curriculum in physics, with two physics lessons per week during all four years of high school education and no extracurricular activities in mathematics or physics. Physics is a compulsory subject in these high schools. The Croatian grading system is a five-level system with grades varying from the lowest (unsatisfactory = 1) to the highest (excellent = 5). Three students were chosen from each school and among them their final physics grades from the previous semester varied from average (3) to excellent (5).

All interviews were conducted no later than a month after students’ final assessment in electromagnetism. Based on students’ descriptions of their physics classes, students were taught physics, including the domain of electromagnetism, using a traditional approach. This approach mostly

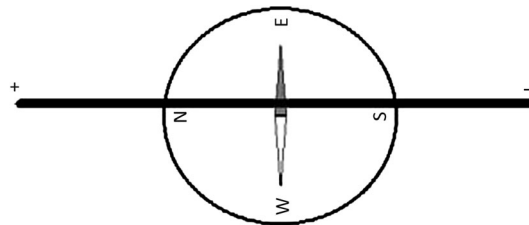

FIG. 1. Experiment 1: the Oersted experiment. A wire was placed above the compass and current was then switched on.

included teaching by telling, with some demonstrations performed by the teacher, but with no students’ hands-on experiments. Prior to the interviews, the purpose and the course of interviews was explained and described to students and only students who agreed with it participated. Participation was voluntary and students were not rewarded for participating. During the interviews, students were shown six demonstrational experiments which they were allowed to investigate on their own: (1) the Oersted experiment (Fig. 1), (2) an experiment demonstrating the direction of magnetic field in various points around a current-carrying coil (Fig. 2), (3) an experiment demonstrating magnetic force on a current-carrying wire (Fig. 3), (4) an experiment demonstrating electromagnetic induction using one coil and a magnet (Fig. 4), (5) an experiment on electromagnetic induction using two coils (Fig. 5) and (6) an experiment demonstrating Lenz’s law (Fig. 6). Students were mostly familiar with experiments 1, 4, 6, as demonstrational experiments performed by their teachers, but not with experiments 2, 3, and 5. Before starting the first experiment, an additional experiment, not included in the study, was shown, so that students could practice the think-aloud technique [35] necessary for this research. This additional experiment consisted of placing a compass in

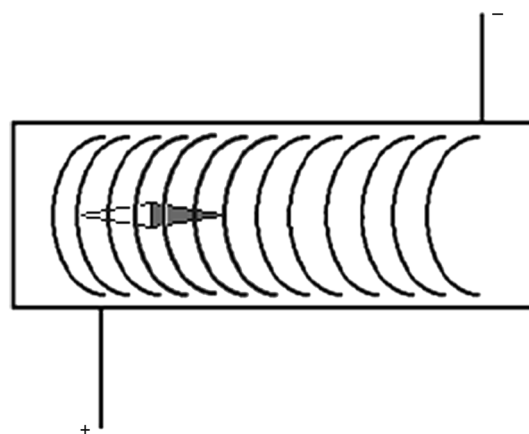

FIG. 2. Experiment 2: demonstrating the direction of magnetic field in various points around a current-carrying coil. A small compass was placed inside a coil and current was then switched on. Students could move the compass inside and around the coil during demonstration.

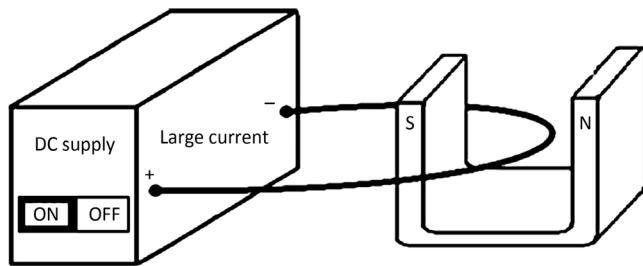

FIG. 3. Experiment 3: demonstrating magnetic force on a current-carrying wire. The current-carrying wire jumped up or down, depending on the orientation of the magnet, when the current was switched on.

front of a student and asking them to describe what they observed and to suggest explanations for why the needle always ended up pointing in the same direction, however it was spun.

During each of the six experiments students were asked to observe the experiment and describe their observations. After the interviewer had been assured that the student noticed the phenomenon of interest, she asked them to suggest an explanation for observations without trying to influence or disrupt their reasoning. Students were not corrected if they had arrived at the physically wrong conclusion, but rather asked additional questions that challenged their reasoning in order to get more information about their explanations. The average duration of an interview was 45 min. Some interviews were shorter, some

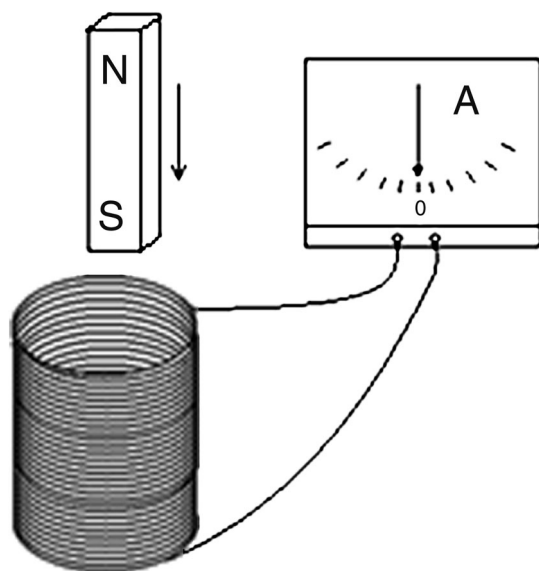

FIG. 4. Experiment 4: demonstrating electromagnetic induction. The magnet was inserted in the coil, left for some time at rest inside it, and then again removed from the coil. Students were allowed to perform the experiment on their own to try different orientations or speeds of the magnet entering the coil. An additional experiment was shown using another coil with less windings than the first one.

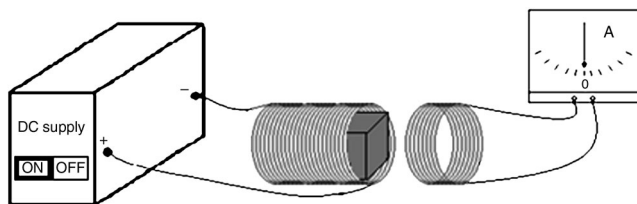

FIG. 5. Experiment 5: demonstrating electromagnetic induction using two coils. Primary coil with an iron core was connected to a dc supply and a secondary coil, with less windings than the primary, to the galvanometer. At first, the coils were positioned parallel to each other, and the current in the large coil was switched on and, after some time, off. The same was repeated for perpendicularly oriented coils and for coils at about 45 degrees to each other.

longer. Some occurred before school (students in Croatia sometimes have school in the afternoon) and some after school. All students seemed motivated and stayed until the end of the interview, although they were free to leave at any given moment, even during the interview. Interestingly, the shortest interview (27 min) was with one of the boys (Saul<sub>3</sub>), who was very motivated and showed a lot of factual and conceptual knowledge, thus arriving quickly at his conclusions about experiments. Girls generally tended to be more talkative than boys, and every interview with a girl lasted longer than 45 min and with a boy shorter than 45 min. None of the students showed loss of attention during the interview, e.g., by giving shorter answers towards the end or not providing any answer. After the interview, students were given feedback on their answers and opportunity to discuss their answers with the interviewer.

Students' names were coded for the purpose of this report so that the code name gives information about the school and the physics grade of the student. For easier reference, students from the first school were labeled with fictitious English first names starting with letter F, from the second school with letter S, and from the third school with letter T. The numbered suffix in the code name is the student's final physics grade from the previous semester. So we have from the first school Fiona<sub>3</sub>, Faith<sub>4</sub>, and Fran<sub>5</sub>, from the second school Saul<sub>3</sub>, Sarah<sub>4</sub>, and Seth<sub>5</sub>, and

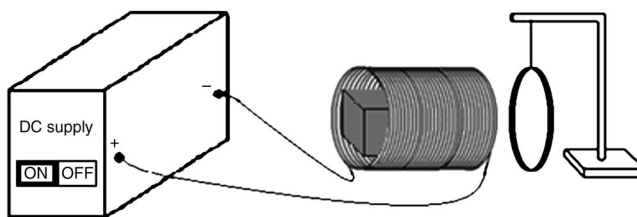

FIG. 6. Experiment 6: demonstrating Lenz's law. An aluminum ring was suspended from a string and put parallel to the large coil with an iron core, an electromagnet. The dc supply was turned on, and after some time, off.

from the third school Tim\_3, Tony\_4, and Ted\_5. Altogether there were four female and five male students.

### A. Coding and categorization

Interviews were recorded with a video camera and transcribed for later analysis. Answers, gestures, and graphical representations were analyzed. All student explanations relating to the same experiment were listed and analyzed according to the guidelines for qualitative data analysis [36]. Reoccurring student difficulties were categorized and labeled A to K.

The transcripts were thoroughly analyzed for similar statements or ideas that could be labeled by a code. At first, similar ideas that represented a common difficulty were color coded. After the first coding process was done, researchers tried to establish links between the codes in order to further reduce the number of codes and form categories. For example, the following difficulties were first coded separately: (a) student states that the north and the south pole of a magnet are also a plus and a minus pole; (b) student states that the north pole of a magnet is attracted to the plus (positive) electric charge. Later, these two students' ideas were merged into the same category (category A): poles of the magnet are confused with plus and minus electric charges. Categories obtained in this way are presented in Tables I and II. We noticed that some categories (student difficulties or ideas) were recurring among students and could be explained by the activation of a similar cognitive resource. For example, several students explained experiment 5 by possibly activating the  $p$ -prim "canceling" and thus arriving to the conclusion that no current is induced in a secondary coil positioned with its axis perpendicular to the primary coil, since the magnetic fields cancel each other out, therefore producing the difficulties categorized with letters D and E (Tables I and II). This final categorization helped us to understand students' reasoning processes that were sometimes triggered by similar pieces of knowledge which led them to arrive at similar conclusions about the investigated phenomenon. The three mental models, which are described later in the text, were also extracted in this way.

In the process of the analysis two researchers went independently through the whole data set, and the third one was consulted on a few ambiguous interpretations. Some differences in interpretation of some students' statements occurred in the process of analysis, but were resolved through discussion among the researchers. Generally, there was a consensus on the meaning and interpretation of the findings. The quotes that were extracted and are presented later in the text were chosen because they best illustrated specific student difficulties, and to give the reader examples of students' actual statements that formed the basis for the conclusions about their reasoning.

## IV. RESULTS AND DISCUSSION

The first three experiments were considered introduction experiments. We tried to get acquainted with students' basic knowledge of electromagnetism before proceeding to the last three experiments, which were about electromagnetic induction and in the main focus of the study. Summaries of students' explanations for each experiment and their main difficulties are presented in Tables I and II.

### A. Introduction experiments (experiments 1–3)

Experiments 1–3 revealed that students had many conceptual and procedural difficulties already with the basic concepts and phenomena of electromagnetism.

As is visible from Tables I and II, students showed poor understanding of the characteristics of the magnetic field around the current-carrying wire and inside a current-carrying coil. Interestingly, all students correctly stated that a current-carrying wire or coil creates (or sometimes they would use the word "induces") a magnetic field, but all except Saul\_3 failed to describe the shape of that field correctly. Two examples of students' graphical representations on experiment 1 are shown in Fig. 7. The magnetic field around a current-carrying coil was correctly described only by three students, but they were unable to determine the magnetic polarity of the coil. Also, the problem of the majority of students during these first assignments was that they kept thinking locally (Difficulty: H in Tables I and II), which prevented them from forming a complete visualization of the magnetic field around the wire or a coil. For example, Faith\_4 only considered the area in the vicinity of the magnetic needle inside a coil, what can be seen from her graphical representation of this phenomenon (Fig. 8).

*Interviewer: Can you try and describe the magnetic field of the coil?*

*Faith\_4: Well, that depends...if this is [needle's] north then just above this north is the south pole [of the coil]... and here is the [needle's] south pole, and just above is the north pole [of the coil]...[draws her graphical representation]*

*Interviewer: ...and what if we moved the needle a little bit deeper [inside the coil]?*

*Faith\_4: The same thing happens...but this time everything just shifts deeper inside.*

Experiment 3, the demonstration of the magnetic force on a current-carrying wire, seems to have been the least familiar to students. Students were mostly confused with the observation, and it took them a long time to even consider that some force might be responsible for the movement of the wire. This was one of the most difficult explanations they had to provide. Only Sarah\_4 and Fran\_5 explained the phenomenon correctly, with Sarah\_4 also applying the right-hand rule to determine the direction of the force. Both of them remembered the experiment from

TABLE I. Summary of students' explanations per experiment. Difficulties expressed during interviews are labeled A through K and described in Table II. RHR stands for right hand rule. The three student models of electromagnetic induction (EMI) are described in detail further in the text.

Student	Experiment 1	Experiment 2	Experiment 3	Experiment 4	Experiment 5	Experiment 6
Fiona_3	States that a current-carrying wire produces magnetic field but cannot describe its shape. Difficulties: A, B, G	Correctly describes the shape of the magnetic field of a current-carrying coil, but cannot determine which magnetic poles is north and which is south. Difficulty: G	Explains that the force which originates at the bottom of a $U$ magnet affects electrons in the wire, and moves the current-carrying wire out of the magnetic field. Difficulty: B	Explains that when the magnet is entering the coil with one pole, the same magnetic pole is also created at the adjacent end of the coil by the current in the coil. She is unsure of that idea, since she does not feel the repulsion when holding the magnet.	Explains that the primary coil's magnetic field extends through the secondary coil when their axes are parallel, and the current appears in the secondary. When their axes are perpendicular, the primary's field does not extend through the secondary coil. No concept of magnetic flux.	Correctly explains that the electromagnet and the aluminum ring have the same adjacent magnetic poles when the current is switched on, and opposite when it is switched off. No concept of magnetic flux and no mention of induced current in the ring.
Saul_3	Correctly describes the shape of the magnetic field of a current-carrying wire. Difficulty: A	Correctly describes the shape of the magnetic field of a current-carrying coil, but determines the orientation of magnetic poles incorrectly. Difficulty: B	Correctly concludes that a magnetic force acts on the current-carrying wire when placed in the magnetic field. Does not use RHR. Difficulty: B	States that the magnet's magnetic field induces a current in the coil while the magnet's field passes through the coil. No concept of magnetic flux. No model of EMI.	Explains that the field lines of the primary coil enter the secondary coil when their axes are parallel, and produce a current in the secondary coil. A sudden change of primary's field produces the current in the secondary coil.	Explains that the ring is repelled or attracted during the onset or offset of electromagnet's magnetic field. When the field becomes stable the rings swings back to its original position.
Tim_3	States that a current-carrying wire is a magnet but cannot describe the shape of its magnetic field. Difficulty: H	States that a current-carrying coil is a magnet. Cannot describe the shape of the coil's magnetic field. Correctly determines the location of magnetic poles of the coil.	Explains that the magnet repels or attracts the current carrying wire. Difficulty: B	Expresses the first model of EMI: overlapping of magnetic fields. Difficulty: D	Explains that the primary coil influences the secondary, and that their magnetic fields interact. Consistent with the first model of EMI. Difficulty: D	States that magnet can attract or repel metals (aluminum). Difficulty: K
Faith_4	Explains that a current-carrying wire affects the magnetic needle like a magnet. Difficulty: H	Describes the position of the magnetic poles of the coil as being always in the vicinity of the magnetic needle (Fig. 8) Difficulty: H	Cannot explain the experiment.	Expresses the first model of EMI: overlapping of magnetic fields. Difficulty: D	Explains that a current appears when magnetic fields of coils with parallel axes merge; magnetic fields of coils with perpendicular axes repel and there is no current. Consistent with the first model of EMI. Difficulties: D, E	Explains that the ring's magnetic field interacts with the stronger field of the larger coil, hence the repulsion and attraction of the ring. Consistent with the first model of EMI. Difficulty: D

(Table continued)



TABLE I. (*Continued*)

Student	Experiment 1	Experiment 2	Experiment 3	Experiment 4	Experiment 5	Experiment 6
Sarah_4	States that a current-carrying wire produces a magnetic field. Field lines start on the wire and are directed downwards (Fig. 7). Difficulty: C	Describes the magnetic field lines of a current-carrying coil as concentric circles parallel to its windings. Difficulties: G, J	Correctly explains the experiment and correctly uses RHR.	Expresses the third model of EMI: interaction of the magnet's and coil's poles. Difficulty: A	Cannot explain the experiment.	Explains that the electromagnet's field repelled the aluminum ring with its magnetic pole. Difficulty: K
Tony_4	States that there are magnetic field lines around the current-carrying wire, but he cannot describe their shape. Difficulties: A, B, C	Explains that a current-carrying coil has two magnetic fields: one inside and the other outside of the coil, but cannot describe their shapes. Difficulty: A, B	Explains that the magnetic field of the bar magnet and the current-carrying wire repel or attract each other. Difficulty: A	Expresses the second model of EMI: magnet repels or attracts electrical charges. Difficulty: B	Explains that the primary's magnetic field has to pass through the middle region of a second coil to attract or repel or hold electrons. Consistent with the second model of EMI. Difficulty: B	Explains that aluminum ring was deflected because the electromagnet's magnetic field repelled it, and claims that it swung back when the electromagnet was switched off. Aluminum has poor magnetic and electric properties, hence the weak effect. Consistent with the second model of EMI. Difficulties: B, K
Fran_5	Explains that the north pole of the magnetic needle is attracted to the positive electric charges on the battery, and the south pole to the negative charges. Difficulties: A, B.	Correctly describes the shape of the magnetic field of a current-carrying coil and correctly applies RHR.	Correctly concludes that a magnetic force had acted on the current-carrying wire that had been placed in a uniform magnetic field.	Correctly states that a current is induced in a coil and correctly determines the magnetic polarity of the coil. No concept of magnetic flux. No model of EMI.	States that the magnetic field of the primary coil induces the current in the secondary, but provides no mechanism. Suggests that the magnetic fields of coils with parallel axes are added and of coils with perpendicular axes subtracted. Partially consistent with the first model of EMI. Difficulties: D, E	Explains that the opposite or same charges are created on the ring and the electromagnet in order that the ring be repelled from/attracted to the electromagnet. Partially consistent with the second model of EMI. Difficulties: A, B, F
Seth_5	Correctly states that the current-carrying wire produces a magnetic field but cannot describe its shape. Difficulty: G	Describes the shape of the magnetic field of the coil near the magnetic needle, but cannot describe the entire field. Difficulties: C, H	Cannot explain the experiment.	Combines two models: the first model of EMI (overlapping of magnetic fields) and the third model of EMI (interaction of the magnet's and coil's poles).	Correctly states that the primary coil induces current in the secondary coil. Gives no mechanism.	Explains that the electromagnet repels and attracts the aluminum ring, because the electromagnet reverses poles when being switched on or off. Consistent with the third model of EMI. Difficulty: K

(*Table continued*)

TABLE I. (Continued)

Student	Experiment 1	Experiment 2	Experiment 3	Experiment 4	Experiment 5	Experiment 6
Ted_5	States that the current-carrying wire produces a magnetic field but cannot describe its shape.	Correctly determines the location of the poles at the ends of the current-carrying coil and correctly uses RHR, but cannot describe the shape of the magnetic field of the coil.	States that the magnet and the electrons in the current-carrying wire create a force on the wire but he cannot describe it further.	Partially expresses the third model of EMI (interaction of the magnet's and coil's poles).	Explains that the primary coil has magnetic field lines as concentric circles parallel to its windings. Its field interacts with the secondary when their axes are parallel, but not when they are perpendicular. No mechanism is described. Difficulties: F, J	Explains that the force of maybe electric (not magnetic) origin moves the aluminum ring, because the aluminum cannot be magnetized. No mechanism is described. Difficulty: B

their lectures, but Saul\_3 did not (even though he is in the same class as Sarah\_4). He answered correctly, but it seemed as if he inferred the existence of some magnetic force from the experiment, and not by remembering it from lectures. In other words, it seemed he was forming his explanation on the spot. Three students stated that the wire moved because of the magnetic interaction between the magnet and the newly created magnetic field of a current-carrying wire, like Tony\_4: "...it [magnetic field] is created around the current-carrying wire, and this [U-] magnet acts with its magnetic field, and then they attract each other." This attraction, he describes, is the reason for the movement of the wire towards the bottom of the U magnet. Tony\_4 seems to be using "generalized springiness"  $p$ -prim, which can be activated when a disruptive influence appears, like the magnetic field of a current-carrying wire, and causes a displacement in the system which was in equilibrium before the current was switched on. Also, students that stated that a force was created and displaced the wire, like Fiona\_3 or Ted\_5, might have activated the "force as a mover"  $p$ -prim, but were not able to explain what created the force. It is possible, although we have not investigated it, that the students' meaning of the term "force" differed from the scientific meaning, as some researchers suggest, who attribute the problems with force to linguistic and ontological difficulties [37].

During experiments, more than half of the students tried to link magnetic force to positive and negative charges. Students kept confusing positive and negative charges with poles of the magnet and spoke of attraction or repulsion among electric charges and magnetic poles (Difficulties: A, B and F in Tables I and II). For example, Tony\_4 stated that the magnetic needle in the current-carrying coil "...shows the north-south direction, i.e., positive pole of the needle, red, points toward the negative part of the magnetic field and the negative pole, to the positive part of the field..." or Saul\_3 by saying: "...so, now the magnetic needle turned in the direction of the magnetic field of this coil...this field flows from the positive to the negative current direction."

Applying the right-hand rule was something of a struggle throughout the whole interview (Difficulty G in Tables I and II). It was rarely applied correctly, whatever the experiment. This comes as no surprise to any experienced high school physics teacher. Croatian physics textbooks [38–40] and educational high school websites [41,42] mention several different right-hand rules, and even some left-hand rules [43] in electromagnetism. It is not surprising that students are confused about all these rules, since every one of them has its own convention and interpretation. Sometimes the direction of the current is represented with the thumb, sometimes with the index finger and sometimes with all of the fingers except the thumb. One solution for this problem at the university level is the introduction of the cross product, but that also activates another set of difficulties [44]. The left-hand rules, though, should be

TABLE II. Difficulties identified during interviews. The difficulty frequency column shows the number of times the difficulty was used to explain an experiment. The student frequency column shows how many students expressed the difficulty.

Label	Difficulty	Difficulty frequency	Student frequency
A	Poles of a magnet are confused with + or – electric charges.	8	5
B	Poles of a magnet can attract or repel stationary electric charges.	12	6
C	Magnetic field lines start or terminate on a current-carrying wire and are not closed curves.	3	3
D	A coil produces magnetic field even without current through it.	6	3
E	Coils with perpendicularly positioned axes have magnetic fields that cancel out or repel (coils may have current running through them or not).	2	2
F	Current running through primary coil induces + or – electric charges on the secondary coil or ring.	2	2
G	Incorrect use of the right-hand rule when determining the direction of the field lines around current-carrying wire and the direction of the north pole of the current-carrying coil.	4	3
H	Local reasoning about the magnetic field: magnetic poles of the magnetic field must be in the vicinity of the compass needle used to probe the field.	4	3
J	The magnetic field lines of a current-carrying coil are represented as concentric circles parallel to its windings.	2	2
K	A magnet and/or current-carrying coil can repel aluminum.	4	4

excluded from physics textbooks since they only bring more confusion for students.

### B. Experiments on electromagnetic induction (experiments 4–6)

As seen from the previous section, students transferred the same difficulties with basic electromagnetic phenomena into their reasoning about experiments 4–6. Again, they had mixed-up electric charges and magnetic poles (difficulties A, B, and F in Tables I and II) and worked it into some mental models of electromagnetic induction. Probably the most representative example was Tony\_4, when during his reasoning about the experiment 4 he stated that “...the magnet, with its magnetic field, acts on the

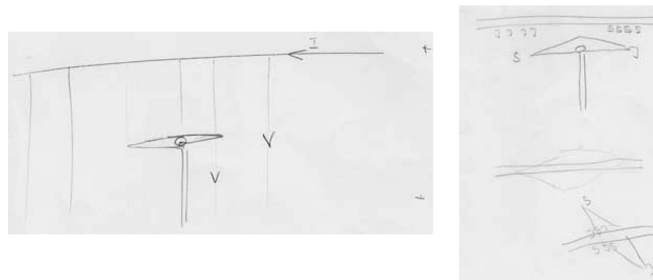

FIG. 7. Examples of students’ graphical representations of magnetic field lines around current-carrying wire. Note that the abbreviations are J for south (“jug” in Croatian) and S for north (“sjever” in Croatian).

*electrons inside the wires of the coil and they start to move...”, which led him to the conclusion that “...when a negative pole of a magnet enters [the coil] it moves electrons. It deflects them.”*

An unexpected difficulty was the idea that a coil has a magnetic field even without current running through it (difficulties D, E in Tables I and II). An example of this difficulty occurred during the experiment demonstrating electromagnetic induction (Fig. 4) when Tim\_3 said the following:

*Interviewer: Why is the ammeter now showing zero value and when we moved the magnet it did not show zero?*

*Tim\_3: I don’t know. I guess we disturbed the field.*

*Interviewer: Whose?*

*Tim\_3: The coil’s.*

*Interviewer: So, the coil has a magnetic field now [when no current is running through it]?*

*Tim\_3: Yes.*

Fran\_5 also implemented the idea about a coil having a magnetic field without current running through it into her reasoning about the experiment demonstrating electromagnetic induction with two coils (Fig. 5). When explaining why there is no current in the secondary coil when it is positioned perpendicularly to the primary coil, and the current in the primary coil is switched on, she concluded,

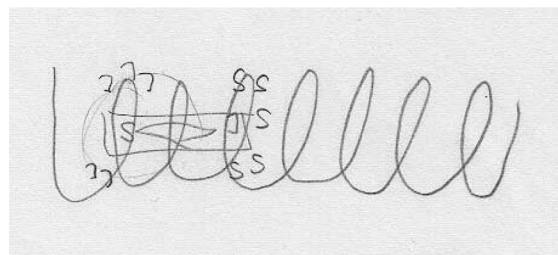

FIG. 8. Faith\_4’s graphical representation of the magnetic field inside the coil indicating local reasoning. Note that the abbreviations are J for south (“jug” in Croatian) and S for north (“sjever” in Croatian).

*Fran\_5: ...their [coils'] magnetic fields are perpendicular.*

*Interviewer: So, this coil [secondary] has a magnetic field now [when no current is running through it]?*

*Fran\_5: It has. While this one [primary] is influencing it...because the current is switched on.*

Fran\_5 did not use this idea during any other experiment, so she probably did not think that every coil has a magnetic field all the time, current carrying or not. She noticed that the primary coil's magnetic field induced the magnetic field of the secondary, but since she obviously had no concept of magnetic flux, she explained the effect with the two positions of coils, with parallel and perpendicular axes, and the fields which add up or subtract. After the interview, the interviewer explained all the experiments, and she laughed at her idea about the coil's magnetic field without current, and said that it now sounded silly, but at that point during the experiment, it had been the only explanation that made sense to her. Like Fran\_5, other students incorporated the same idea into their reasoning during experiments 4–6, even though none of the students claimed before (for example, on experiment 2) that the non current-running coil had a magnetic field. Probably the rest of the students also implemented simplified reasoning to explain the experiments about electromagnetic induction, which yielded the conclusion that magnetic fields of a coil and magnet merge during experiment 4 (Tim\_3, Faith\_4, Seth\_5) or that magnetic fields of perpendicular coils cancel out in experiment 5 (Faith\_4, Fran\_5). A possible interpretation for the latter explanation might be the activation of the *p*-prim canceling. In order to explain why there is no current in the secondary coil, when it is positioned perpendicular to the primary, some students needed to invent two opposite influences, i.e., two perpendicular magnetic fields that cause no net effect. This reasoning was then transferred to a mathematical scheme, which led Fran\_5 to conclude that perpendicular magnetic fields of coils “...are summed and canceled, hence no current effect”.

Experiment 4 was, according to the interviewees, the one most commonly performed in schools during electromagnetism lessons, and the only one out of all experiments performed during interviews that had been seen before by all of the students. During the interviews it was noticed that some students seemed to have formed mental models of electromagnetic induction, and that three different models reoccurred among them. The interviewer noticed that all students, except Fran\_5, seemed to have created an explanation for the shown phenomenon on the spot, which led to the conclusion that the model of electromagnetic induction might not have been formed during teaching. Only Fran\_5 explained the phenomenon partially correctly, stating that the current is induced in the coil, and determined correctly which pole is created on which side of the coil during electromagnetic induction, but even she did not

incorporate the rate of change of magnetic flux into her explanation (Table I).

### ***1. The first mental model of electromagnetic induction: Overlapping of magnetic fields***

Tim\_3 and Faith\_4 started to form their mental models of electromagnetic induction from the idea that a magnet produces a magnetic field, but that a coil also, while no current is running through it, has a magnetic field as well. While a magnet is entering the coil, the two magnetic fields, one produced by the magnet and the other by the coil, start to overlap, creating one common field. As a result of the overlapping process, electric current appears in the coil, which is then registered by the galvanometer. When the magnet is at rest inside the coil, no current is produced in the coil, because there is no change in this newly created common field. But if the magnet is pulled away from the coil, the common magnetic field starts to separate into two initial fields: one produced by the magnet and the other produced by the coil. Because of the separation of the fields, an electric current is again produced in the coil, but this time in the opposite direction.

*Faith\_4: ...this coil has already a magnetic field around itself, and a magnet has a magnetic field, and then they come in contact, these two fields. Then they became one magnetic field, so that means they establish some balance...*

*Faith\_4: ... then, I pull out [of the coil] the magnet, now two separate fields are created, but during the transition from one field to two, a reaction occurs as a negative current value.*

*Interviewer: What happens when we put the magnet inside [the coil]?*

*Tim\_3: It disturbs this [the coil's] field.*

*Interviewer: Ok. It disturbs this field. Why does nothing happen when they [the magnet and the coil] are at rest?*

*Tim\_3: Because nothing is disturbing the field.*

*Interviewer: Does the magnet have a magnetic field?*

*Tim\_3: It does.*

*Interviewer: You said that the coil has a magnetic field. What happens now with these two fields [the magnet and the coil are at rest]?*

*Tim\_3: Well, now they are in balance.*

Faith\_4 and Tim\_3 seem to be using the equilibrium or dynamic balance *p*-prim when speaking about the two fields. They view the two magnetic fields as two influences that produce a stable state when the magnet rests inside a coil. The mechanism for current production is not evident. Separation of the balanced magnetic field into two fields might be in line with the generalized springiness *p*-prim, where Faith considers the separation as a disruptive influence on equilibrium which generates a current as a



result. The dominant conceptual resource that she is using is magnetic field.

## 2. The second mental model of electromagnetic induction: magnet repels or attracts electrical charges

Tony\_4 began forming his model with the idea that a magnet can repel or attract electrical charges at rest. This idea is known from previous studies [1,45]. When one pole of the magnet approaches and enters a coil, it repels (or attracts) electrons inside the coil. When this happens, a current is detected by the galvanometer. If the magnet is at rest inside the coil, electrons are not moving, and therefore no electric current is detected, but they are still displaced from their original positions (the field “holds” them). While the magnet is being removed from the coil, the electrons simply return to their original positions, and while doing so electric current in the opposite direction is detected by the galvanometer.

*Tony\_4: ...the magnet, with its magnetic field, acts on the electrons inside the wires of the coil and they start to move*

*Tony\_4: ...when a negative pole of a magnet enters [the coil] it moves electrons. It deflects them... and pushes them downwards and then it spreads...starts to spin them through the coil...*

*Interviewer: And what happens when we pull the magnet out [of the coil]?*

*Tony\_4: Then it pulls them in the other direction. They move back.*

Tony\_4 seems to have been using “force as a mover” *p*-prim [26] to explain why the electrons in the coil started to move. He had to find a force which could move the electrons, and suggested that the force comes directly from the magnet. Later in his argument he may be using “force as a deflector” and “force as a spinner” or “guiding” to explain how the electrons move through the coil. Finally, at the end of the description, he may be using “force as a mover” or “continuous force” to explain the return of the electrons and the current in the opposite direction.

## 3. The third model of electromagnetic induction: interaction of the magnet’s and coil’s poles

Sarah\_4 ascribed positive and negative poles to the magnet and the coil. If the magnet and the coil are faced with opposite poles, there is an attractive force between them, and the electric current is produced in the coil. The current appears, and is detected by the galvanometer, when the coil and the magnet interact. The direction of the current depends on whether the interaction is attractive or repulsive. Seth\_5 explained that when the magnet and the coil attract or repel, they create a current, but he also mentioned that the magnet is entering the magnetic field of the coil and that their magnetic fields created the current. This last part

of his model agrees with the first model of electromagnetic induction. Ted\_5 only partially expressed the third model by stating that the force of the magnet acts on the coil, without clear specification of what this force affects. Students could not provide an underlying mechanism for this interaction, so how exactly these forces create the current in the coil remains unknown.

*Ted\_5: ...so, there are forces acting from south to north pole [of a magnet]. Then maybe, when the force acts on the coil this deflection happens [on the ammeter]. When we pull it [the magnet] out, then it goes in the opposite direction because the force is now opposite.*

Ted\_5 seems to be using force as a mover *p*-prim in his explanation, but the force is now identified as the magnetic force between the magnet and the coil.

*Sarah\_4: ... if we pull it [the magnet] away [from the coil], that would mean the current is created.*

*Interviewer: You said if there are opposite poles [of the coil and the magnet] ...?*

*Sarah\_4: ...yes. Then they attract [each other], but if we pull them apart, then we are creating some force which attracts it again...because they have opposite poles [the magnet and the coil].*

*Interviewer: And what does this force do?*

*Sarah\_4: It creates some specific direction of the current...*

*Sarah\_4: ...when I approach or pull it [the magnet] away... then this is the way to change the current direction.*

It is noticeable that Sarah’s thinking goes also in the direction of finding a force that is responsible for the movement of the current. The dominant conceptual resource in this case is the attraction of the opposite magnetic poles.

*Interviewer: What happened? [When the magnet entered the coil]*

*Seth\_5: One magnetic pole attracted it [the coil] ... and the other repelled it.*

*Seth\_5: That is how the current was created. Since in the opposite case a current can create a magnetic field, so here that field can create a current.*

*Interviewer: Why is there no current now? [The magnet is stationary above the coil.]*

*Seth\_5: Because the magnet is too far away and it does not attract it [the coil].*

Seth\_5 obviously remembers the fact that a current-carrying wire induces a magnetic field but still it is hard to say whether the dominant conceptual resource he is using is the magnetic field or the force. Part of his reasoning is going in the direction of finding the attractive force between

the magnet and the coil, which might have originated from activating force as a mover  $p$ -prim, yet at another moment of his reasoning he seems to have activated the magnetic field as a dominant conceptual resource.

Maybe the most surprising outcome of the interviews was that none of the students mentioned the physical quantity of magnetic flux while reasoning about electromagnetic induction. Only two students mentioned on experiment 5 that the magnetic field created by the primary coil is somehow affecting the secondary coil, but were missing the concept of magnetic flux to fully explain the experiment. An example may be the following reasoning of Fiona\_3.

*Fiona\_3: Well, when the coils are like this [parallel], then... around this first coil there are circles [Fiona\_3 is demonstrating with a waving hand the way magnetic field lines curve around, enter and flow inside the primary coil] and they sort of extend through this [secondary] coil... and when they are turned like this [perpendicular], then it seems to me that they cannot extend through them.*

*Interviewer: And what is it that needs to extend through the secondary coil?*

*Fiona\_3: Well...the magnetic field of this [points to the primary] coil ... and that coil induces the creation of the magnetic field in this [secondary] coil.*

Her mental representation of the primary magnetic field extending to the secondary coil is not incorrect, but she should have used the concept of magnetic flux for better description. That concept is obviously missing, although it was covered in her physics class. This is discouraging, considering that in most cases it is impossible to reason about electromagnetic induction without considering the concept of magnetic flux. This concept is very difficult for students, but even more difficult is the rate of change of magnetic flux. Time and school resources available for students to form this concept is very limited and often they do not have the opportunity to investigate it, experiment with it, and reason about it on their own. The mental model of this very abstract and complex concept appears to have not been fully formed during school lessons by the interviewees, but as seen in Fiona\_3's reasoning presented above, some students showed the very beginnings of that concept formation.

An even more simplified version of their reasoning was noticed when students explained that the opposite, or the same magnetic poles, are induced during electromagnetic induction: in experiment 4 between the magnet and the coil, in experiment 5 between the primary and the secondary coils, and between the electromagnet and the aluminum ring in experiment 6 (e.g., Fiona\_3, Sarah\_4, Seth\_5, Ted\_5; Table I). This simplified explanation of electromagnetic induction, that magnetic poles appear on a coil during EMI, can be useful for understanding the outcome

of some high school experiments and problems regarding Lenz's law, but they do not support the development of the model of EMI. More stress should be put on opportunities for students to develop, test, and apply the idea of magnetic flux and its rate of change than on recognition of occurring magnetic poles in demonstration experiments mentioned above.

With the experiment demonstrating Lenz's law (experiment 6) the most common students' reasoning was that the ring was deflected because the coil repelled it, and that it returned to its original position only when the current was switched off in the coil, even though they had observed that the ring returned to its vertical position very soon after the current was switched on and while it was not yet switched off. Some students even accompanied their explanation with clarification that the aluminum ring with no current running through it had the same adjacent magnetic pole with the coil. However, a nonmagnetized metal cannot be repelled by a magnetic field, only attracted to it. While explaining this phenomenon, the students did not seem to realize that the aluminum ring had to have induced magnetic poles for the magnetic field of the coil to repel it. When confronted with a direct question about the mechanism of this interaction, they did not elaborate on it. Students knew what an electromagnet was and how it could be created. This is taught in the eighth grade of elementary school in Croatia, so it was not unusual that students recognized the current-carrying coil as a magnet. They obviously had the resources to understand Lenz's law and they activated some appropriate resources for reasoning about it, but were missing several steps in reasoning towards the correct conclusion.

Their *train of thought* went something like this: (i) activation of the knowledge that a current-carrying coil is an electromagnet; (ii) ring deflecting from the coil activated the resource about magnets repelling or attracting other magnets; (iii) the ring's behavior suggests the ring is a magnet and its poles should be oriented opposite of the coil's, since it is deflected from it. The reasoning stopped here since students did not know how to explain it further. The fourth step in their reasoning should have been to implement the already activated knowledge about electromagnets and recognize that some current must be running through the ring to create the ring's magnetic field. A further step would be to conclude that the current must have been induced in the ring due to the changing magnetic flux, and that the direction of the induced current is opposite from the direction of the one running through the coil since the ring's field was oriented opposite of the coil's field.

The implementation of Lenz's law requires many steps in reasoning as well as functional understanding of many previously learned concepts from electromagnetism, which makes this law difficult for students to apply.

### C. Consistency of students' mental models

Most of the students' mental models of electromagnetic induction seem to have formed while they were explaining experiment 4. Were these models consistently used to explain other experiments on electromagnetic induction (experiments 5 and 6)?

The first model, formed independently by Tim\_3 and Faith\_4, was used by both of them during reasoning about experiment 5. Here is an example of Faith\_4's reasoning:

*Interviewer: [after performing experiment 5 with parallel coils] Can you try and explain this?*

*Faith\_4: Maybe it's because of these magnetic fields? Because we have two coils, and these magnetic fields merged again into one field. While they were merging, as a result the pointer shifted [on the ammeter]. It showed negative current.*

*Interviewer: And when the current is switched off?*

*Faith\_4: It [the pointer of the ammeter] moves in the other direction. That means that this one big magnetic field split into two different fields and as a result current occurred.*

*Interviewer: [After performing the experiment with perpendicular coils] What about this?*

*Faith\_4: Nothing. Because this magnetic field [of the first coil] did not enter this coil [secondary]... it's like they repel.*

Faith\_4 again seems to be activating the same  $p$ -prims as during reasoning about experiment 4, with the addition of possibly activating the canceling  $p$ -prim, to explain why there is no current when the coils are positioned perpendicularly. She continued to use her model on experiment 6:

*Faith\_4: The electromagnet has a stronger magnetic field than the ring and that repelled it when the current was switched on. It [the ring's magnetic field] could not immediately take it [the electromagnet's magnetic field]. When we switched the current off, then it attracted the ring, because maybe the part of this energy was given to the ring.*

Faith\_4 may have activated the overcoming  $p$ -prim to explain the repulsion and the attraction of the aluminum ring, viewing the magnetic field of the ring and the electromagnet as two influences in which one overpowers another.

Tim\_3, on the other hand, did not use his model on the last experiment. He just stated that: "*magnet can repel and magnet can attract metals*".

The second model of electromagnetic induction was used consistently by Tony\_4. For experiment 5 he gave the following explanation:

*Tony\_4: Magnetic field is first turned on, it attracts electrons in this coil [points to the primary coil] and*

*holds them all the time... ...this magnetic field [of the primary coil] passes through the middle of this [secondary] coil and that is how it holds the electrons [in the secondary]. When we place the coils like this [perpendicularly], then the field only passes partially and therefore does not affect it [the secondary coil].*

He still used the same mental model of EMI, but when the coils were perpendicular he could not explain how the force could guide or spin the electrons through the secondary coil (use of the "force as a spinner" or "guiding"  $p$ -prim), and this might have been the reason for him to state that the primary's magnetic field cannot affect the electrons in the secondary coil. However, he did realize during the experiment 6 that something was not right with the idea that the electrons are attracted to the magnetic poles, but did not try to produce another explanation.

The third model of electromagnetic induction was used by Seth\_5 for experiment 6, but not for the experiment 5. Ted\_5 and Sarah\_4 did not use their model after the experiment 4. For experiment 5 Seth\_5 stated

*Seth\_5: ... this [primary coil] creates magnetic polarity on this metal [secondary coil], and it sort of becomes a magnet. This is the reason that current is created. Because this [secondary] coil enters the magnetic field of the magnet and that causes the current."*

Here, he does not use the third model of EMI, but remembers from physics lessons that a secondary coil induces current when it enters the primary's magnetic field. In the case of no current, when the coils were perpendicular, he seemed to activate the  $p$ -prim canceling, and explained that "*...there is no current. The magnetic field of the secondary coil is positioned downward [perpendicular to the primary's magnetic field]*". While reasoning about the experiment 6, it seems that he activated the generalized springiness and force as a mover  $p$ -prims to explain the electromagnet's disruptive influence on the aluminum ring, which then repelled or attracted the ring. Interestingly, he reasoned that the polarity of the electromagnet, and not the polarity of the aluminum ring, changes when switching the current in the electromagnet on and off.

### D. Students' epistemological resources for learning physics

Some students may believe that their common sense does not play a role in predicting and explaining physics phenomena. This might drive students towards the belief that memorizing separate facts, definitions, and formulas is the key to physics knowledge and thus they might not strive for the structure and coherence in that knowledge. The counterproductive epistemological resource often activated during interviews was a belief that explanations for the observations should have been read or heard from authority (textbook, teacher), and were treated as *factual and*



*communicable knowledge* [21]. This might have interfered with students' ability to form new ideas, which they had to create, since it seems they have not done so during electromagnetism lessons. For example, Seth\_5 had that problem when trying to explain the Oersted's experiment, and even though several additional experiments were performed by him or the interviewer (changing the position of the wire, placing the compass needle above, below, and parallel to the wire), he still couldn't form any idea about the configuration of the magnetic field lines around the wire. After all this, Seth\_5 admitted

Interviewer: [after performing all experiments] ...What could the magnetic field lines around a current-carrying wire look like?

Seth\_5: ...

Interviewer: *What are your thoughts?*

Seth\_5: *Physics' course material.*

This idea that the answer should have been written somewhere, and that he only needed to recall what he had read or heard seemed to block his ability to reason scientifically. This occurred throughout Seth\_5's and Ted\_5's interview, which were very short, since lot of their answers were often "I don't know..." They showed a lot of factual knowledge and activated many pieces of knowledge [26,28], but searching through them often seemed to block their reasoning processes. Unlike Ted\_5 and Seth\_5, Fran\_5's interview lasted over an hour. She kept activating various conceptual resources, sometimes appropriate and sometimes not. She was going through her physics course material in her head, searching for the explanations for the experiment. She was better than her colleagues with the same physics grade at making connections between various resources and at discarding the inappropriate ones. It took her a long time to formulate an answer that she was satisfied with. After the interview, she admitted she was not accustomed to think about physics in this way. She said she was excellent in mathematics, and that alone was enough for her to have an excellent grade in physics.

All of the excellent students (physics grade 5) seemed to be treating physics knowledge *as propagated stuff* [29,31], and to believe it should come from an authority, e.g., a book or a teacher. It would be wrong to assume that their scientific reasoning skills are poor. The problem might be in not being accustomed to use those skills while uncovering physics phenomena. It would be more productive for students to adopt the view of physics knowledge *as fabricated stuff* instead of *propagated stuff* [29,31].

However, it must be acknowledged that the complexity of the task placed before students was high, since they are novices in the domain of electromagnetism with still unstable knowledge that needs considerable scaffolding [46], and not used to analyzing and interpreting experiments. Therefore, it is possible that occasionally students might not have had enough confidence in their ability to

reason about the subject and therefore tried to recall knowledge that came from authority (teacher or textbook). A similar finding was reported by Tongchai *et al.* [47] in the context of mechanical waves. They suggest that in general, students tend to guess and invoke different ideas while they are formulating prior to consolidating. However, in an interview situation students' may be hesitant to do so and more likely to resort to authority like the textbook.

Contrary to excellent students, Saul\_3 was accustomed to think about physics phenomena by often constructing explanations. He admitted he was not very good at solving mathematical problems, and he described himself as lazy for studying factual data. He seemed to be treating knowledge *as fabricated stuff*, or inferred from observations, and as such he was more productive in producing explanations than the others. His explanations about experiments were filled with observations that were missed by the others. For example, he was the only one to have suggested that field lines created by the primary coil pass through the second coil, and cause the current to flow in the secondary coil, and also distinguished coils' positions by pointing out the importance of the surface area—all that without knowing the physical concept of magnetic flux.

Interviewer: *What is the difference between these two positions of the coil [parallel and at an angle]?*

Saul\_3: *When they are at an angle, the surface of interaction is much smaller because of the larger distance...*

He also suggested that the sudden change in magnetic flux through the coil (even though he did not name it magnetic flux) induces current in that coil.

Saul\_3: *...well, when we turn the current on [in the primary], there is a sudden increase of current, magnetic field occurs ... and maybe because it happens all so quickly, a very, very big change occurs in this [secondary] coil and that is seen on the galvanometer. The same happens when we turn it off, magnetic field disappears and that is also a very, very big change, and the galvanometer detects it.*

All students showed insecurities about explaining the phenomena, and needed incentive to continue their reasoning process. They were quick to discard an inappropriate resource and activate another one, showing that they do have the skills to reason scientifically about physics phenomena. The educational system in Croatia holds nominally these skills in high regard, but the reality of school practice is different. Large numbers of students per class in high schools, and the oversized physics curriculum often may not allow the development and evaluation of other than factual knowledge and mathematical skills in physics. Hopefully, this should change with the new high school physics curriculum in development. We should help



students to realize that receiving information from authority is not the only, and not even the most productive way of learning physics, and encourage them more to investigate physics phenomena and construct and evaluate models and explanations for those phenomena. After all, history of physics shows that was a fruitful path for investigating nature.

## V. CONCLUSIONS AND IMPLICATIONS

The results of the study indicate that high school students that were taught physics by the traditional approach may lack functional understanding of basic concepts of electromagnetism, which can also seriously hamper their reasoning about the complex phenomenon of electromagnetic induction. They showed many conceptual and procedural difficulties in their reasoning. In answer to our first research question, we have identified and described those difficulties. Some of them are known from previous studies, but some have not been identified before, to our knowledge. Students were aware that a current-carrying wire produces a magnetic field, but failed to describe it even after having experimented with it; they confused electrical effects with magnetic effects, could not determine the direction of the magnetic force, and completely avoided the concept of magnetic flux. These findings are consistent with the research by Maloney *et al.* [1]. The new difficulties were related to students' misunderstanding of the shape of magnetic field lines, location of the magnetic poles, and the origin of the magnetic field of the coil. One new difficulty that stands out is the idea that the coil may have a magnetic field when no current is running through it, expressed several times during interviews as a part of students' explanations of electromagnetic induction.

In answer to our second research question we have analyzed students' models of electromagnetic induction and the consistency of their use. Students did not seem to readily recognize the phenomenon of electromagnetic induction in demonstration experiments, as was similarly reported in interviews by Park [9], and they seemed to have invented new mental models on the spot to explain their observations. Of the three reoccurring mental models of EMI only the second one (magnet repels and attracts electric charges), which was used consistently by some students throughout the experiments about EMI, had an explanation for the underlying mechanism of the current induction in the coil. It uses the well-known confusion of static charges and magnetic poles, but this is the first time to our knowledge that this idea is used to explain the mechanism of EMI, though it is known that it had been used for explaining electromagnetic interactions [11]. The other two student models of EMI provided no explicit mechanism for the induction of current.

The interviews created the impression that students may not have formed models of EMI during their classes on electromagnetism, and that the models that emerged in the

interviews were not the result of students' prior ideas about these phenomena, but may have been formed on the spot, as students were prompted to give explanations for the experiments. The similarities of some explanations and models that the students independently produced may be attributed to students' activation and use of similar basic cognitive resources, and the linking of those to the concrete experimental circumstances. For example, when trying to find the explanation for the induction of current in experiment 4, students seem to have been dominantly using the force as a mover *p*-prim [26] in the second and third models to explain why the electrons in the coil started to move. They had to find a force which could move the electrons, and some suggested that the magnet acts directly on the electrons, whereas others suggested that the force responsible for the motion of electrons was between the magnet and the magnetic poles of the coil. Different models seemed to result from different dominant conceptual resources to which the students were mapping their similar reasoning elements.

A month after traditional instruction on electromagnetism, it seemed that students had no models of electromagnetic induction, and when prompted to construct some, but not helped in the process, they constructed inadequate models based mostly on their simplified reasoning elements (*p*-prims) and available conceptual resources. An important implication for instruction could be that students should be encouraged more to create explanations and models during instruction, in an interactive environment, where they could engage in discussions with other students and the teacher about their different models, and get the opportunity to test their ideas and later refine them. The invented models in this study were used consistently by only a minority of students. It seems that for most of the students the models were provisory tools for creating explanations, and they did not show too much concern about being consistent in different explanations. If possible, physics teachers should try to create and use opportunities for obtaining insight and intervening in students' reasoning, and build and support students' need for coherence in their models and knowledge.

They might also entice formation of more appropriate and productive epistemological attitudes, since epistemological resources played an important part in students' explanations. For those students who viewed learning physics as memorizing factual data and formulas, possible activation of the epistemological resource *knowledge as propagated stuff* [22] led them to search through their experience and knowledge, and if they had not found an answer there, they simply chose to stop their thinking process. For them, it might be strange to continue thinking about a problem for which they have no ready answer, but it would be wrong to assume they are not able to. Students who may have activated epistemological resources *knowledge as fabricated stuff* or *knowledge as free creation* were more willing to offer explanations for the observed experiments.

The results of the study all support the resource-based view of students' knowledge [21,26–33]. We hope that our findings will help put more emphasis on the need to develop student functional understanding of physics concepts already in high school physics classes.

Regarding limitations of the study, we are aware that there are also other ways of collecting data when researching student reasoning and conceptual difficulties which may also provide different valuable insights, such as concept maps or componential analysis [36]. It is important to note that findings from the qualitative research cannot be generalized, but are usually used for formulating research questions for large-scale quantitative studies. Yet we do feel that they are still valuable, because even though the number of interviewed students was small (nine) there were reoccurring models among them, indicating the possibility of some underlying general tendencies in student reasoning which may lead to the formation of similar models. We believe that these underlying tendencies are consistent with students' use of basic cognitive elements,  $p$ -prims, in the formation of the mental models. Our small-scale qualitative in-depth

analysis was exploratory in its nature and allowed us to test hypotheses that would be inaccessible by quantitative research. By detecting recurring elements in students' misconceptions, even in this small sample, we gained valuable insight in student reasoning about EMI. Also, if we had more detailed information about the teaching that the students had been exposed to it would enable us to investigate possible links between the teaching and the formation of students' conceptual models.

The findings from this qualitative research were implemented in creating a questionnaire about electromagnetic induction that was administered to a larger sample of high school students in Croatia. Soon we plan to analyze and publish that data to quantify students' difficulties with electromagnetic induction and to produce a tutorial for tackling them.

### ACKNOWLEDGMENTS

The authors acknowledge the financial support from the Slovenian Research Agency (research core funding No. P1-0060).

- 
- [1] D. P. Maloney, T. L. O'Kuma, C. J. Hieggelke, and A. Van Heuvelen, Surveying students' conceptual knowledge of electricity and magnetism, *Am. J. Phys.* **69**, S12 (2001).
  - [2] M. Planinic, Assessment of difficulties of some conceptual areas from electricity and magnetism using the Conceptual Survey in Electricity and Magnetism, *Am. J. Phys.* **74**, 1143 (2006).
  - [3] M. Saarelainen, A. Laaksonen, and P. E. Hirvonen, Students' initial knowledge of electric and magnetic field—more profound explanation and reasoning models for undesired conceptions, *Eur. J. Phys.* **28**, 51 (2007).
  - [4] M. C. Pocovi and F. Finley, Lines of Force: Faraday's and students' view, *Sci. Educ.* **11**, 459 (2002).
  - [5] M. C. Pocovi, The effects of a history-based instructional material on the students' understanding of field lines, *J. Res. Sci. Teach.* **44**, 107 (2007).
  - [6] E. Bilal and M. Erol, Investigating students' conceptions of some electricity concepts, *Lat. Am. J. Phys. Educ.* **3**, 193 (2009).
  - [7] P. F. W. Preece, The concepts of electromagnetism: a study of the internal representation of external structures, *J. Res. Sci. Teach.* **13**, 517 (1976).
  - [8] E. Bagno and B. S. Eylon, From problem solving to a knowledge structure: An example from the domain of electromagnetism, *Am. J. Phys.* **65**, 726 (1997).
  - [9] J. Park, Modeling analysis of students' processes of generating scientific explanatory hypotheses, *Int. J. Sci. Educ.* **28**, 469 (2006).
  - [10] E. Bagno, B. S. Eylon, and E. Ganiel, From fragmented knowledge to a knowledge structure: Linking the domains of mechanics and electromagnetism, *Phys. Educ. Res. Am. J. Phys. Suppl.* **68**, S16 (2000).
  - [11] J. Guisasola, J. M. Almudi, and J. L. Zubimendi, Difficulties in learning the introductory magnetic field theory in the first years of university, *Sci. Educ.* **88**, 443 (2004).
  - [12] J. Guisasola, J. M. Almudi, and K. Zuza, University students' understanding of electromagnetic induction, *Int. J. Sci. Educ.* **35**, 2692 (2013).
  - [13] M. Loftus, Students' ideas about electromagnetism, *School Science Review* **77**, 280 (1996).
  - [14] K. Zuza, J. Guisasola, M. Michelini, and L. Santi, Rethinking Faraday's law for teaching electromotive force, *Eur. J. Phys.* **33**, 397 (2012).
  - [15] I. Galili, D. Kaplan, and Y. Lehavi, Teaching Faraday's law of electromagnetic induction in introductory physics course, *Am. J. Phys.* **74**, 337 (2006).
  - [16] W. M. Thong and R. Gunstone, Some student conceptions of electromagnetic induction, *Res. Sci. Educ.* **38**, 31 (2008).
  - [17] K. Zuza, J. M. Almudi, A. Leniz, and J. Guisasola, Addressing students' difficulties with Faraday's law: A guided problem solving approach, *Phys. Rev. ST Phys. Educ. Res.* **10**, 010122 (2014).
  - [18] L. Ding, R. Chabay, B. Sherwood, and R. Beichner, Evaluating an electricity and magnetism assessment tool: Brief electricity and magnetism assessment, *Phys. Rev. ST Phys. Educ. Res.* **2**, 010105 (2006).

- [19] M. A. Kohlmyer, M. D. Caballero, R. Catrambone, R. W. Chabay, L. Ding, M. P. Haugan, M. J. Jackson Marr, B. A. Sherwood, and M. F. Schatz, Tale of two curriculae: The performance of 2000 students in introductory electromagnetism, *Phys. Rev. ST Phys. Educ. Res.* **5**, 020105 (2009).
- [20] J. Guisasaola, J.M. Almudi, M. Ceberio, and J.L. Zubimendi, Designing and evaluating research-based instructional sequences for introducing magnetic fields, *Int. J. Sci. Math. Educ.* **7**, 699 (2009).
- [21] D. Hammer, Epistemological beliefs in introductory physics, *Cognit. Instr.* **12**, 151 (1994).
- [22] M. Planinic, W.J. Boone, R. Krsnik, and M. Beilfuss, Exploring alternative conceptions from Newtonian dynamics and simple DC circuits: Links between item difficulty and item confidence, *J. Res. Sci. Teach.* **43**, 150 (2006).
- [23] D. A. Norman, *Some observations on mental models*, in *Mental Models*, edited by D. Gentner and A. L. Stevens (Lawrence Erlbaum Associates, Mahwah, NJ, 1983).
- [24] K. A. Strike and G. J. Posner, Conceptual change and science teaching, *Eur. J. Sci. Educ.* **4**, 231 (1982).
- [25] K. A. Strike and G. J. Posner, A revisionist theory of conceptual change, in *Philosophy of Science, Cognitive Psychology, and Educational Theory and Practice*, edited by R. Duschl and R. Hamilton (SUNY Press, Albany, NY, 1992), pp. 147–176.
- [26] A. A. di Sessa, Toward an epistemology of physics, *Cognit. Instr.* **10**, 105 (1993).
- [27] D. Hammer, A. Elby, R. E. Scherr, and E. F. Redish, *Resources, framing, and transfer*, in *Transfer of Learning from a Modern Multidisciplinary Perspective*, edited by J. Mestre (Information Age Publishing, Greenwich, CT, 2005), pp. 89–120.
- [28] D. Hammer, Student resources for learning introductory physics, *Phys. Educ. Res., Am. J. Phys. Suppl.* **68**, S52 (2000).
- [29] D. Hammer and A. Elby, Epistemological resources in *Fourth International Conference of the Learning Sciences*, edited by B. Fishman and S. O'Connor-Divelbiss (Lawrence Erlbaum Associates, Mahwah, NJ, 2000), pp. 4–5.
- [30] D. Hammer and A. Elby, On the form of a personal epistemology, in *Personal epistemology: The psychology of beliefs about knowledge and knowing*, edited by B. K. Hofer and P. R. Pintrich (Lawrence Erlbaum Associates, Mahwah, NJ, 2002), pp. 169–190.
- [31] D. Hammer and A. Elby, Tapping students' epistemological resources, *J. Learn. Sci.* **12**, 53 (2003).
- [32] A. Elby and D. Hammer, On the substance of a sophisticated epistemology, *Sci. Educ.* **85**, 554 (2001).
- [33] A. Elby and D. Hammer, Epistemological resources and framing: A cognitive framework for helping teachers interpret and respond to their students' epistemologies, in *Personal Epistemology in the Classroom: Theory, Research, and Implications for Practice*, edited by L. D. Bendixon and F. C. Feucht (Cambridge University Press, Cambridge, England, 2010), pp. 409–434.
- [34] J. Qian, Sampling, in *International Encyclopedia of Education*, 3rd ed., edited by P. Peterson, E. Baker, and B. McGaw (Elsevier, Oxford 2010), Vol. 7.
- [35] E. Charters, The use of think-aloud methods in qualitative research an introduction to think-aloud methods, *Brock Educ. J.* **12**, 68 (2003).
- [36] V. K. Otero and D. B. Harlow, Getting Started in Qualitative Physics Education Research (2009), see, <http://www.per-central.org/items/detail.cfm?ID=9122>.
- [37] D. T. Brookes and E. Etkina, "Force", ontology, and language, *Phys. Rev. ST Phys. Educ. Res.* **5**, 010110 (2009).
- [38] T. Andreis, M. Plavcic, and N. Simic, *Fizika 2–2nd Grade High School Textbook* (Profil, Zagreb 2013).
- [39] D. Horvat and D. Hrupec, *Fizika 2—Pojmovi I Koncepti—2nd Grade High School Textbook* (Neodidacta d.o.o., Zagreb 2013).
- [40] J. Labor, *Fizika 2–2nd Grade High School Textbook* (Alfa, Zagreb 2006).
- [41] Neodidacta Multimedija, see [http://www.neodidacta.com/multimedija/osnove\\_elektrotehnike\\_1/sila\\_na\\_vodic.html](http://www.neodidacta.com/multimedija/osnove_elektrotehnike_1/sila_na_vodic.html) 2015.
- [42] Artas, see: <http://www.artas.hr/magneti/magnetizam.htm> 2016.
- [43] N. Brković, *Elektricitet* (Luk d.o.o., Zagreb 1995).
- [44] M. B. Kustus, Assessing the impact of representational and contextual problem features on student use of right-hand rules, *Phys. Rev. Phys. Educ. Res.* **12**, 010102 (2016).
- [45] D. P. Maloney, Charged poles?, *Phys. Educ.* **20**, 310 (1985).
- [46] C. Lindstrøm and M. D. Sharma, Teaching physics novices at university: A case for stronger scaffolding, *Phys. Rev. ST Phys. Educ. Res.* **7**, 010109 (2011).
- [47] Tongchai, M. D. Sharma, I. D. Johnston, K. Arayathanitkul, and C. Soankwan, Consistency of students' conceptions of wave propagation: Findings from a conceptual survey in mechanical waves, *Phys. Rev. ST Phys. Educ. Res.* **7**, 020101 (2011).